

**Joint Attention and Echoic Eavesdropping in Wild Bottlenose
Dolphins (*Tursiops aduncus*)**

by Justin Gregg

A dissertation submitted for the degree of
Doctor of Philosophy

School of Psychology
University of Dublin,
Trinity College

April 2008

Declaration

I, the undersigned, declare that this thesis has not been submitted to this or any other university.

I declare that all of the material contained in this thesis, unless otherwise stated, is entirely my own work.

I declare my consent to the library of Trinity College, Dublin that I agree that the library may lend or copy this thesis upon request.

Signature_____ Date_____

Dedication

I dedicate this thesis to my parents David and Susan Gregg. They have always supported me in everything I have ever wanted to do; a rare and incredibly generous quality. Any success I have in life will ultimately find its roots in the many years of toil and trouble that they have undertaken on my behalf. Thank you!

Acknowledgements

This research is a direct result of the generosity of two remarkable mentors; my supervisors, Howard Smith and Kathleen Dudzinski. Perhaps because of this generosity, his incredible power of foresight, or maybe even gullibility, Howard agreed to take me on as a student after listening to my impassioned (and only partially well informed) pitch concerning a brilliant plan for a project involving studying the dolphin mind. Without Howard's enthusiasm, counsel, and his tolerance for my endless need for clarification concerning statistical procedures, this research would never have gotten off the ground. Kathleen is also to be credited with equally marvelous powers of foresight, having bought this research project 'sight unseen' as it were. I have never met an active researcher who is more giving of her time and energy to her students. Without her trust in me and my abilities, and without the access to her phenomenal field sites and data archive, this research project would have been but a pipedream. Kathleen has provided me countless opportunities to interact with members of the scientific community over the years, and has involved me in a number of her own projects (from research to film making). Her ability to thoughtfully edit and quickly return whatever madcap piece of writing I send her way is perhaps the reason why this project took 3 years instead of 30. I was extremely lucky to have been a student of both Kathleen and Howard.

There are many others that must receive thanks for humoring me during the last three years. Even though I spent little of my time wandering the halls of Áras an Phiarsaigh in the last year of my degree program, there are many fellow students to whom I am indebted to for their helpful advice and friendship; Ziggy, James, Jen, Tara, and Caren (most of whom are years gone at this point), and many others. And of course Caoilte, who helped me develop many of my ideas early on, and who was instrumental in distracting me from just about everything other than discussions of flares and scoops. I also thank Fiona Newell for allowing me to sit in on her research group's meetings, and providing me helpful advice from time to time. Thanks also to Jean Quigley and Fiona for their guidance in their roles as my student advisors. I would also like to thank my thesis examiners; Manuel dos Santos and Tim Trimble. Their insightful comments, helpful suggestions, enthusiasm and support created a pleasant atmosphere for my *viva voce*. I am grateful for them helping this process to end on a high note.

Special thanks to Catherine Kemper for generously providing me with *T. aduncus* skull measurement data that were used in the creation of my 3D MASC model, as well as much helpful advice. Many thanks also to J.Y. Wang for his expert advice concerning young dolphin skulls and inter-population variation for *T. aduncus*. I am grateful to Christer Blomqvist and Stan Kuczaj who provided helpful comments on sections of this thesis, as well as many other researchers who answered my questions: Mats Amundin, Whitlow Au, Marc Xitco, Steve Dawson, Shoji Itakura, Vincent Janik, and Paul Lepper, among others. Thanks also to Jeanette Thomas for providing me the opportunity to work with her on *Aquatic Mammals*. I am much obliged to Sean Kent whose advice in the early stages of my degree program was instrumental in guiding this project in the right direction. Also, David Janiger has

been incredibly generous in making PDF copies of hard-to-get articles available to MARMAM subscribers, and, through this service, his contribution to this research cannot be overlooked – thank you Dave!

I am grateful to the Dolphin Communication Project (DCP) and my research associates who have provided not only help, support and guidance, but friendship: Kristy, Kelly, Darcie and Kathy. Thanks also to John and Umi for the early morning cappuccino sessions and many hours of pleasant conversation. A very special thanks to Kogi (Mampu-san) and all of the many friends I made on Mikura Island (too numerous to mention here!) for their generosity over the years in lending support to the strange tall American who visits their beautiful island each summer. どうもありがとうございます. Much gratitude must be given to the Mikura boat captains who are so generous in allowing DCP researchers to ride-along and collect the data that made this research project possible, and to the Mikura-jima middle school (both teachers and students) for welcoming me into their classrooms on several occasions. Thanks to James Brinck, Mai Sakai, Tadamichi Morisaka and Tomoko Fujimaki for their friendship and generous access to spare bedrooms; a precious commodity in Tokyo.

Above all, I must thank Ranke. Her contributions to this research, and to my own personal well being over the years are incalculable. This project, the latest in a series of what can only be considered eccentric endeavors, was given her stamp of approval early on. She has spent countless hours listening to convoluted monologues concerning dolphin behavior, acoustical physics, statistics, and lord knows what else. Thanks to her tolerant personality and many insights (she just may have invented the 3D MASC method) this madcap plan ultimately resulted in success. Whomever you choose to credit (cupid, destiny or dumb luck), I am certainly the better for having met and married Ranke.

Publications arising from the current work

Published Articles

Gregg, J. D., Dudzinski, K. M. & Smith, H. V. (2008) 3D MASC: a method for estimating relative head angle and spatial distance of dolphins from underwater video footage. *Animal Behaviour*, 75(3), 1181-1186.

Gregg, J.D., Dudzinski, K.M., Smith, H.V. (2007) Do dolphins eavesdrop on the echolocation signals of conspecifics? *International Journal of Comparative Psychology*, 20: 65-88.

Gregg, J.D., Dudzinski, K.M., & Smith, H.V. (in prep) Eavesdropping behaviors in wild Indo Pacific bottlenose dolphins (*Tursiops aduncus*) *Aquatic Mammals*

Gregg, J. D. (2007) Book Review: *Rational Animals?* *Aquatic Mammals*, 33(2), 246-247.

Published Abstracts

Gregg, J.D., Dudzinski, K.M., & Smith, H.V. (2007) Do you hear what I hear? Testing the eavesdropping hypothesis on a population of wild Indo-Pacific bottlenose dolphins (*Tursiops aduncus*) 17th Biennial Conference for The Society for Marine Mammalogy, Cape Town, South Africa 29th November - 3rd December, 2007

Gregg, J.D., Dudzinski, K.M., & Smith, H.V. (2007) A cognitive model of joint attention in dolphins. 44th Annual Meeting of the Animal Behavior Society, Burlington, Vermont July 21 -25th, 2007

Book Chapters

Dudzinski, K., Thomas, J., & Gregg, J. (2008). Communication. In W. F. Perrin, B. Würsig & J. G. M. Theewissen (Eds.), *Encyclopedia of Marine Mammals*. San Diego: Academic Press. (in press)

Summary

The aims of this thesis were twofold: 1) to determine if wild Indo-Pacific bottlenose dolphins (*Tursiops aduncus*) engage in behaviors predicted to follow directly from the ‘echoic eavesdropping’ hypothesis in a natural setting, and 2) to explore how these behaviors are related to a discussion of joint attention in dolphins.

In Chapter 1, the reader is provided with an overview of the issues surrounding the study of joint attention and eavesdropping in dolphins. A brief overview of the echoic eavesdropping hypothesis is provided, as well as the ways in which a capacity for echoic eavesdropping might lead to the proven capacity for captive dolphins to engage in complex joint attention behaviors. The aims and goals of this research project are presented, outlining the value of this study in answering questions with respect to the role that echoic eavesdropping might play in the behavior of wild dolphin species.

In Chapter 2, the reader is provided with a detailed review of the echoic eavesdropping hypothesis, its development, and influence on the writings of behavior scientists. Despite very limited evidence that dolphins may actually engage in echoic eavesdropping, this behavior (set of behaviors) has been implicated as a possible explanation for a number of observed dolphin behaviors, including swim formation, social behavior, echolocation use, etc. A review of the relevant literature pertaining to joint attention in dolphins is also provided. Echoic eavesdropping has often been cited as the basis for which dolphins appear to grasp both referential pointing and joint attention behaviors under experimental conditions. Possible explanations for this relationship are given, including a novel cognitive model for joint attention in dolphins: the bimodal joint attention model.

Chapter 3 provides a brief overview of the data collection methods used in this study. Details are provided concerning a novel technique used in the measurement of distance and head angle between dolphins as applied to underwater videography developed for this study (3D MASC).

In Chapter 4, the results of the analyses concerning the role of silence in an echoic eavesdropping scenario are presented. The results suggest that dolphins in an eavesdropping scenario do remain more silent than normal dolphins. Silence for the eavesdropper appears to be related to the presence of the investigating dolphin’s echolocation click train. It was found however that head angle was a predictor of echolocation production by the eavesdropper, but in ways not predicted by the hypothesis; the closer the dolphins heads are together, the more likely an eavesdropper will echolocate. This peculiar finding led to the development and introduction of a novel eavesdropping hypothesis.

Chapter 5 provides the results of analyses concerning the role that swim positions (in terms of distance and head angle between dolphins) play in an echoic eavesdropping scenario. The results of these tests do not corroborate the prediction that a dolphin positioned in an ideal position for echoic eavesdropping (as predicted by the hypotheses) will remain in that position, nor that a dolphin will

attempt to initiate an ideal position during episodes where echoic eavesdropping could occur. The results do suggests that dolphins alter their swimming distance and head angle across time during an eavesdropping scenario in consistent patterns which could be related to some form of eavesdropping.

Chapter 6 provides a summary of these findings. Discussion of both the echoic eavesdropping hypothesis, and joint attention in dolphins (i.e., the bimodal joint attention model) are revisited in light of the findings of this study. A novel/alternative hypothesis is introduced in order to explain some of these findings: the multi-source echoic eavesdropping hypothesis. The limitations and strengths of this study are presented, as well as suggestions for future research.

Contents

Declaration	ii
Dedication	iii
Acknowledgements	iv
Publications	vi
Summary	vii
Chapter 1 Introduction	1
1.1 Dolphin echolocation and eavesdropping	1
1.2 The role of joint attention	3
1.3 Aims of the thesis and research questions	4
Chapter 2 Echoic Eavesdropping and Related Psychological Concepts	8
2.1 Echoic eavesdropping	8
2.1.1 Overview of a dolphin's biosonar transmission system	8
2.1.2 The development of the echoic eavesdropping hypothesis	9
2.1.3 Experimental and observational support	11
2.1.4 Influence of the hypothesis	12
2.1.5 The listening position problem	13
2.1.6 The off-axis problem	14
2.1.7 The features problem	17
2.1.8 The outgoing click problem	18
2.1.9 The silence problem	19
2.1.10 The social problem	22
2.1.11 Summary	22
2.2 Relevant psychological concepts	23
2.2.1 Introduction	23
2.2.2 Eye direction and gaze following	23
2.2.3 Joint attention	28
2.2.4 Referential pointing	51
2.2.5 Summary	65
2.3 Echoic eavesdropping cognitive model	66
2.3.1 Introduction	66
2.3.2 Bimodal joint attention	69
Chapter 3 Method	94
3.1 Subjects	94
3.2 Equipment	96
3.2.1 MVA	96
3.2.2 ECD	98
3.3 Procedure	99

3.3.1	Data Set 1: baseline dyad echolocation behavior	102
3.3.2	Data Set 2: echoic eavesdropping behavior	105
3.3.3	3D model for measurements of head angle and distances	109
3.3.4	Validity	115
3.3.5	Inter-rater reliability tests and validity	116
3.3.6	Reliability of the ECD and video audio data	117
Chapter 4	Does the Eavesdropper Remain Silent?	119
4.1	Overview	119
4.2	Baseline vs. echoic eavesdropping behavior	119
4.2.1	Controlling for calves	121
4.2.2	Controlling for distance and head angle	122
4.3	Exploring relationships between variables	124
4.3.1	Distance	124
4.3.2	Head angle	126
4.3.3	Distance and head angle combined	132
4.3.4	Clockface swimming position	133
4.3.5	Gender	134
4.3.6	Click train duration and other factors	135
Chapter 5	Does the Eavesdropper Remain in or Initiate an Ideal Eavesdropping Position?	139
5.1	Defining the OZE	139
5.2	Distance	143
5.3	Head angle	151
5.4	Testing the OZE: head angle and distance combined	160
5.5	Exploring relationships between variables	161
5.5.1	Distance and head angle	161
5.5.2	Clockface swimming position	162
5.5.3	Click train length	165
5.5.4	Causality, silence and the OZE	167
Chapter 6	General Discussion	169
6.1	Summary of main findings	169
6.2	Implication and interpretation of results	174
6.2.1	Overview	174
6.2.2	Echoic eavesdropping	175
6.2.3	Joint attention	181
6.3	Limitations and strengths of this study	188
6.4	Directions for future research	189
6.5	Concluding remarks	190
References		191
Appendices		227

Index to Figures

Figure 2.3.1 Alignment Cue Sensitivity (ACS) – body orientation.....	77
Figure 2.3.2 Alignment Cue Sensitivity (ACS) – head orientation	78
Figure 2.3.3 Echolocation Cue Sensitivity (ECS) – transmitted echolocation beam perception (TEBP)	79
Figure 2.3.4 Echolocation Cue Sensitivity (ECS) – echoic eavesdropping perception (EEP)	80
Figure 2.3.5 Bimodal joint attention model.....	81
Figure 3.1.1: Location of Mikura-jima (139°36'E, 33°52'N) (image from NASA Landsat – World Wind software).....	95
Figure 3.1.2: Mikura island – nearshore area with core habitat of dolphin population shaded gray (image from NASA Landsat – World Wind software).....	95
Figure 3.2.1: The MVA4 schematic	97
Figure 3.2.2: The MVA4 photograph.....	97
Figure 3.2.3: An ECD circuit board	98
Figure 3.2.4: Plot ECD1 shows a typical echolocation ‘click’ (raised cosine) input. Plot ECD2 shows the output corresponding waveform. ©2000 copyright NewLeap Limited, UK.	99
Figure 3.3.1: The MVA4 in use by the author (image from Mio Yanagase).....	102
Figure 3.3.2 Waveform showing onset of D1 and D2 echolocation clicktrains	105
Figure 3.3.3 Example of the ‘mature’ 3D dolphin head model used in the 3D MASC method	110
Figure 3.3.4 Head models representing the four relative dolphin age classes used in the 3D MASC method.....	111
Figure 3.3.5 2D image captured from underwater video and imported into the 3D environment of Google SketchUp®	113
Figure 3.3.6 Models and 2D image viewed from above.....	114
Figure 3.3.7 Models are repositioned so that the rostrum tips are aligned in the 3D environment, creating an isosceles triangle	115
Figure 4.3.1 Regression of angle vs. distance at 1 sec with outliers 2SD of the mean removed	133
Figure 4.3.2 Clockface swimming position.....	134
Figure 4.3.3 Regression of duration D1’s echolocation bout vs. delay between D1 and D2’s echolocation	136
Figure 4.3.4 Regression of length of D1 vs. D2 echolocation train – outlier removed	137
Figure 5.1.1 OZE relative to dolphin body width.....	141
Figure 5.1.2 OZE relative to dolphin length.....	142
Figure 5.1.3 OZE relative to dolphin head angle.....	143
Figure 5.2.1 Plot showing changes in distance for each conditions (inside vs. outside OZE) across time.....	146
Figure 5.2.2 Plot showing changes in distance for each conditions (inside vs. outside OZE) across time.....	150
Figure 5.3.1 Plot of changes in mean head angle across time for dolphins inside the OZE (OZE at 10°)	

.....	154
Figure 5.3.2 Plot of changes in mean head angle across time for dolphins inside the OZE (OZE at 10°) – starting at ‘0.5 sec’ instead of ‘start of event’	156
Figure 5.3.3 Plot of changes in mean head angle across time for all dolphins– starting at ‘0.5 sec’ instead of ‘start of event’	157
Figure 5.3.4 Plot of changes in mean head angle across time for dolphins outside the OZE starting at ‘0.5 sec’ instead of ‘start of event’	158
Figure 5.5.1 Frequency of clockface swimming position for D2 at start of event	163
Figure 5.5.2 Clockface swimming position for D2 in the OZE at .5 sec	164
Figure 5.5.3 Clockface swimming position for D2 outside the OZE at .5 sec.....	165

Index to Tables

Table 2.1 Summary of pointing; structure and function.....	61
Table 2.2 Summary of the evidence for joint attention related abilities in animals.....	66
Table 2.3 Comparison of mechanisms and behaviors involved in joint attention and bimodal joint attention for dolphins.....	93
Table 3.1: Supplemental data collected during research	100
Table 3.2 Summary of data collection for each of the three field seasons used in this study.....	101
Table 3.3: Variables for Data Set 1	104
Table 3.4: Variables for Data Set 2 – part 1	107
Table 3.5: Variables for Data Set 2 – part 2	108
Table 3.6 Measurements of the specimens used to arrive at 3D head models for the four age categories	112
Table 4.1 Logistic regression model for head angle variables at various time intervals	127
Table 4.2 Logistic regression model for various time intervals controlled for D1 cease echolocation	128
Table 4.3 Chi-square with Yates’ correction tests at various angle cutoff points for each time interval	129
Table 4.4 Independent sample t-tests for head angle at various time interval in relation to echolocation activity.....	131
Table 4.5 Pearson’s Correlation – distance and head angle at all time intervals.....	132
Table 5.1 Mean distance measurements per time interval for dolphins inside OZE vs. outside OZE defined at 1 m.....	147
Table 5.2 Independent t-test comparing mean distance between dolphins inside and outside OZE at each time interval	148
Table 5.3 Planned contrasts for distance for inside the OZE between start of event and each time interval.....	148
Table 5.4 Planned contrasts for distance for outside the OZE between start of event and each time interval.....	149
Table 5.5 Independent t-test comparing mean distance between dolphins inside and outside OZE at each time interval from .5 sec as start of event.....	151
Table 5.6 Central tendency for episodes where D2 does and does not initiate 10° head angle	152
Table 5.7 Chi-square testing D2 inside and outside the OZE at ‘start of event’	161
Table 5.8 Chi-square testing D2 inside and outside the OZE at ‘.5 sec’ used as start of event.....	161
Table 5.9 Logistic regression showing different head angle conditions with length of D1’s click train as the predictor	166

Chapter 1 Introduction

“For instance, on the planet Earth, man had always assumed that he was more intelligent than dolphins because he had achieved so much - the wheel, New York, wars and so on - while all the dolphins had ever done was muck about in the water having a good time. But conversely, the dolphins had always believed that they were far more intelligent than man - for precisely the same reasons.”

-Douglas Adams, *Hitchhiker’s Guide to the Galaxy*

1.1 Dolphin echolocation and eavesdropping

Echolocation (often referred to as ‘sonar’ or ‘biosonar’) is a behavior whereby acoustic signals are produced, resulting in echoes which are used to glean environmental information (e.g., size and shape of space, presence of obstacles, distance to object, object size and composition, object movement). Although often considered unique to echolocating bats (of the sub-order Microchiroptera) and toothed whales (of the sub-order Odontoceti), a variety of species in fact use calls for echolocation, including rodents, amphibians, bears, and birds (See Fenton, 1980). What makes Microchiroptera bats and odontocetes unique is their use of ‘structured calls’ – that is, signals that have evolved to be uniquely capable of identifying specific features of a target and its position, and not simply the presence of an obstacle (Fenton, 1980). These echolocation calls are characterized as broadband, highly structure signals, and are usually accompanied by the presence of characteristic organs, tissues, morphology and behaviors specifically evolved to produce, receive and process echolocation. For all echolocating bat and dolphin (odontocete) species, echolocation calls are capable of completely replacing the sense of vision when necessary (Masters & Harley, 2004), a fact that reveals the extent to which these echolocating mammals have embarked upon unique evolutionary paths.

The biosonar system common to all odontocetes has been subjected to much scientific scrutiny in the last half century. Following early speculation by Arthur McBride that dolphin species might possess sonar abilities similar to bats (Wood & Evans, 1980), pioneering research carried out by Winthrop N. Kellogg in the early 1950’s introduced the world to the idea that dolphins are capable of producing broadband ‘sound pulses’ that function like sonar, allowing them to locate food and navigate obstacles (Kellogg, 1970; Kellogg *et al.*, 1953). Kellogg called this ability ‘echo-ranging’. Similar work conducted independently and concurrently by William Schevill and Barbara Lawrence bolstered these claims, but it was Kenneth Norris who, in the 1960’s, provided overwhelming evidence that dolphins had an ability to generate and utilize sonar signals (for a review of these experiments see Au, 1993; Wood & Evans, 1980). In the years since these early experiments, scientists have learned a great deal about what is now commonly referred to as ‘echolocation’ or ‘biosonar’ in toothed cetaceans. The central questions have always been “how does echolocation work” and “what kind of information does it make available to the animal?” A large body of literature has been produced in response to these questions (e.g., Au, 1993; Au, 2003; Thomas *et al.*, 2004), with experimental work ongoing.

Despite substantial knowledge of the structure and function of odontocete biosonar systems that has been revealed under experimental conditions, little is known about the way these systems function in a natural setting as part of the normal behavioral repertoire of wild dolphins (see discussions by Barrett-Lennard *et al.*, 1996; Evans & Awbrey, 1988; Herzing & dos Santos, 2004; Li *et al.*, 2005; Madsen *et al.*, 2004; Popper, 1980). In his definitive work on the subject of dolphin sonar, Au (1993, p. 271) went so far as to claim that, despite what we have learned in the lab, “we do not have the foggiest idea of how dolphins utilize their sonar in a natural setting.” Many studies in recent years sought to address this problem - new and more cost-effective technologies have allowed scientists to record the broadband echolocation signals of wild free-ranging odontocetes with enough accuracy to allow for a more comprehensive analysis of acoustic and behavioral data (Akamatsu *et al.*, 2005; Au, 2003; Au & Benoit-Bird, 2003; Dudzinski *et al.*, 1995; Herzing & dos Santos, 2004; Lammers *et al.*, 2004; Madsen *et al.*, 2004; Schotten *et al.*, 2004). These studies have provided insight that complements a new line of inquiry pertaining to dolphin echolocation, namely “how does a dolphin use its echolocation in a natural environment?”

Bat species are known to emit a near constant stream of echolocation clicks during their active periods (Tyack & Clark, 2000), and, in view of the wealth of information this kind of system is capable of providing, it might be assumed that dolphins would also engage their active sonar system on a frequent basis. However, many recent studies revealed that, among dolphins, echolocation is employed much more sparingly in the wild than previously thought. Dolphins are capable of localizing and tracking prey using passive acoustic cues alone (Wood & Evans, 1980), and studies of passive listening foraging strategies (Barrett-Lennard *et al.*, 1996; dos Santos & Almada, 2004; dos Santos *et al.*, 1990; Evans & Awbrey, 1988; Gannon *et al.*, 2005) led to the conclusion that silent hunting techniques may be prevalent, possibly serving as a primary means of prey detection in some foraging situations (Herzing, 2004; Herzing & dos Santos, 2004). Eavesdropping has also been implicated as a possible explanation for sparse echolocation usage (Götz *et al.*, 2005). A special form of eavesdropping has been proposed for echolocating odontocetes (Jerison, 1986; Xitco & Roitblat, 1996), and it is this hypothesized process, termed ‘echoic eavesdropping’, that is the focus of this study.

The term ‘eavesdropping’ is commonly used to describe a situation where one animal is able to discern valuable information by means of intercepting the signals generated by a conspecific, predator or prey (see review by Peake, 2005). It manifests itself in various forms and in various modalities across taxa: for example, female black-capped chickadees (*Poecile atricapilla*) eavesdrop on the territorial songs of males as a means of evaluating a mate (Mennill *et al.*, 2002); the female corn earworm moth, (*Helicoverpa zea*) whose pheromones, intended to attract males of the same species, are intercepted by parasitic female wasps of the chalcid genus *Trichogramma* (Stowe *et al.*, 1995); and the tungara frog (*Physalaemus pustulosus*) whose calls attract the predatory fringe-lipped bat (*Trachops cirrhosus*) (Page & Ryan, 2005). However, a distinction must be made between the concept

of eavesdropping in the traditional sense outlined above, and the ‘echoic eavesdropping hypothesis’ as it relates to dolphin echolocation (Dawson, 1991; Götz *et al.*, 2005; Xitco & Roitblat, 1996). The current form of the echoic eavesdropping hypothesis for dolphin species refers exclusively to a scenario wherein one dolphin does not transmit any echolocation clicks of its own, but rather listens to the echolocation clicks and click echoes produced by conspecifics in order to gain information about its environment. A dolphin, then, is eavesdropping specifically on the echolocation of other dolphins, and not on other sounds in the environment, nor on non-echolocation signals produced by conspecifics. It assumes a complex level of object and environmental information is available to the eavesdropping animal through the click echoes it receives. In this study, the term ‘echoic eavesdropping’ is used to refer to the hypothesis just discussed, whereas ‘eavesdropping’ or ‘classic eavesdropping’ are used to refer to the traditional definition common to animal communication/signaling (see discussions of ‘classic eavesdropping’ in McGregor, 1993; McGregor, 2005).

The echoic eavesdropping hypothesis could be formulated as follows: a dolphin in an appropriate listening position relative to an actively echolocating conspecific(s) is able to receive and utilize detailed object and environmental information from the generated click echoes. With the exception of a review publication arising from this study (Gregg *et al.*, 2007) the echoic eavesdropping hypothesis has never been formally presented, despite the observational work and experiments that have tested certain aspects of it (Götz *et al.*, 2005; Xitco & Roitblat, 1996). This study has helped to not only formalize the hypothesis, but to conduct a comprehensive test of the hypothesis on a wild population of dolphins. To this end, a full review of the echoic eavesdropping hypothesis is provided. I will describe in more detail the hypothesis in its current form in section 2.1, specifying the earlier hypotheses and suggestions from which it is derived. I will then highlight some difficulties with the current hypothesis arising from the many untested assumptions upon which it rests. In section 2.2, I will provide an overview of the psychological concepts often linked with echoic eavesdropping in the literature; gaze following, joint attention and referential pointing. In section 2.3, I will discuss a potential model for how these psychological concepts may facilitate echoic eavesdropping. This will provide the appropriate backdrop for a justification of the research aims of this project and an explanation of the research questions central to this study as described in section 1.3.

1.2 The role of joint attention

Central to this study is Xitco *et al.*’s (2001) discussion of how echoic eavesdropping may be linked to psychological concepts like gaze following, referential pointing, and joint attention. Joint attention, an ability underpinned by the capacity to follow gaze or direction of attention, is a psychological/behavioral process often linked with other cognitive facilities attributed to cognitively complex social animals. Joint attention has been linked to language acquisition in infants (Baldwin & Moses, 1996; Dunham & Dunham, 1992; Morales *et al.*, 2000; Morales *et al.*, 1998; Sabbagh *et al.*, 2006; Tomasello, 1988), language evolution (Kohler *et al.*, 2002; Rizzolatti & Craighero, 2004), to the ability to attribute emotions and mental states to others, and Theory of Mind (Baron-Cohen, 1995;

Charman *et al.*, 2000; Gopnik *et al.*, 1994; Tomasello, 1995) and is closely linked with the concept of gaze following and the understanding of intention in others (Calder *et al.*, 2002; Corkum & Moore, 1998; Frith & Frith, 2001; Meltzoff *et al.*, 2001). It has been studied in both pre-verbal human infants and diverse animal species including dolphins. Language and cognition research with dolphins has led to speculation that dolphins have the capacity for understanding gaze and attention as exhibited by their human trainers (Xitco *et al.*, 2004), resulting in joint attention. These studies also demonstrated a dolphin's ability to comprehend referential pointing – a psychological concept related to joint attention (Herman *et al.*, 1999; Pack & Herman, 2004; Tschudin *et al.*, 2001). Some observational data suggest that both wild and captive dolphins may engage in spontaneous pointing behavior (Dudzinski *et al.*, 2003; Xitco *et al.*, 2001).

In the case of dolphin biosonar behavior, echoic eavesdropping appears to be associated with joint attention and referential pointing, and yet this relationship is not clearly defined. Joint attention is traditionally understood as reliant upon visual attention, involving both 'gaze following' and 'gaze monitoring', although it has been pointed out that it need not be limited to vision alone (see discussion by Tomasello, 1995). There is a fundamental difference between the notion of joint attention in echolocating dolphins and joint attention in other species; for the case of dolphins and echoic eavesdropping, visual monitoring may occupy a minor role, with the process of joint attention occurring primarily within the acoustic modality. This may present a situation where a hitherto unexplored concept, 'bimodal joint attention', may be involved (see section 2.3). Bimodal joint attention may be restricted to animals utilizing active echolocation, and thus unique to odontocetes (and conceivably microchiroptera bat species). To further explore this idea, it is first vital to understand the link between the cognitive processes mentioned here (gaze following, joint attention, and referential pointing) and the results of relevant behavioral studies. The cognitive processes referred to above are intimately linked, yet not synonymous. A considerable amount of research has been conducted in recent decades to describe these and other related processes. This field of inquiry has been particularly fruitful, in terms of both philosophical and psychological theory, and experimental progress. A comprehensive overview of competing theories is beyond the scope of the review for this study; instead, an attempt will be made to place these processes within a simplified and coherent framework that will be relevant to the discussion at hand. Furthermore, the relevant behavioral studies focusing on both animals and humans will be discussed, as well as relevant neurological studies. A review of joint attention and relevant psychological concepts is provided in section 2.2.

1.3 Aims of the thesis and research questions

The aims of this thesis were twofold: 1) to determine if wild dolphins engage in eavesdropping behaviors as predicted by the results of experiments that have hitherto provided experimental support for the echoic eavesdropping hypothesis (Xitco & Roitblat, 1996), and 2) to determine if these eavesdropping behaviors can be understood in relation to the literature on joint attention and

referential pointing for dolphins (Herman *et al.*, 1999; Xitco *et al.*, 2001; Xitco *et al.*, 2004). The study of wild dolphin behavior, especially under water, is notoriously difficult (see discussions by Au, 1993; Herzing, 2000). Major challenges for this kind of observational research are:

- Limited access to wild dolphin populations habituated to researchers or research vessels
- Poor light conditions and visibility
- Dangerous environmental conditions for human observers
- Inability to determine which animal is vocalizing
- Potential disturbance of subjects' natural behaviors by presence of researchers

Although visibility and environmental conditions were a challenge for this study, access to a tolerant/habituated dolphin population was possible (see section 3.1). Overcoming the problem of determining which dolphin is vocalizing/echolocating was aided considerably by the equipment used for this study (see section 3.2). Most importantly, instead of disturbances to the natural behavior of the dolphins caused by the presence of humans in the dolphins' environment, this study took advantage of the presence of the researcher(s) as part of the study design: the echolocation activity central to this study was echolocation directed at the researcher's camera/array (designated the 'target'). Thus, for this study, the presence of the researchers and the camera/array was incorporated directly into the study design.

In order to test the echoic eavesdropping hypothesis on a population of wild dolphins, the hypothesis was modified (taking into consideration the results of relevant experiments) for this study. Xitco and Roitblat's (1996) experiment has provided strong evidence that a dolphin positioned close to an echolocating dolphin will be able to utilize target backscatter in order to perform target detection and discrimination. The results of their test confirmed the 'eavesdropping hypothesis' as they had described in the introduction of the published article summarizing their results. Nonetheless, many questions still remain with respect to potential problems and pitfalls of the hypothesis in its current form (see section 2.1 for a complete review). In order to undertake a study of eavesdropping in the wild, the echoic hypothesis was reformulated for this study, which resulted in a conceptual hypothesis that provides the backdrop for data collection and analysis:

Conceptual Hypothesis: Dolphins traveling in dyads engage in echoic eavesdropping behaviors when inspecting a target

Despite the fact that many researchers have speculated as to how echoic eavesdropping behaviors might manifest themselves in the behavior of dolphin *groups* (Dawson, 1991; dos Santos & Almada, 2004; Fellner *et al.*, 2006; Götz *et al.*, 2005; Harley *et al.*, 1995; Herzing, 2006; Janik, 2005; Jerison, 1986; Johnson & Norris 1986; Johnson & Norris, 1994; Kuc, 2002; Norris & Dohl, 1980; Xitco & Roitblat, 1996), dolphin *dyads* were chosen as the focus for this study in view of the fact that the only

experimental work concerning a dolphin's capacity for eavesdropping was performed on a dolphin pair (Xitco & Roitblat, 1996). In order to create testable hypotheses that predict the behavior of wild dolphins when engaged in echoic eavesdropping, a detailed analysis of the echoic eavesdropping hypothesis as presented by Xitco and Roitblat, as well as the results of their experiments, was conducted (see section 2.1). Two main predictions follow from this analysis are: 1) that eavesdropping dolphins will remain silent while engaged in echoic eavesdropping, and 2) that eavesdropping dolphins need to be in an 'ideal' position in order for echoic eavesdropping to occur. The precise mechanics of these predictions is available in the review section. Three operational hypotheses were generated from this analysis:

H1- An echoic eavesdropping dolphin remains silent for the duration of the investigating dolphin's echolocation click train during investigative events

H2 - A dolphin positioned in an appropriate eavesdropping position when another dolphin initiates echolocation remains in that swim position throughout the duration of the investigating dolphin's echolocation click train during investigative events

H3 - A dolphin not positioned in an appropriate eavesdropping position when another dolphin initiates echolocation attempts to initiate an appropriate swim position after the start of the investigating dolphin's echolocation click train during investigative events

Concerning silence: as will be discussed in the following literature review section (2.1), the echoic eavesdropping hypothesis assumes an eavesdropping dolphin will remain silent in an echoic eavesdropping scenario. For Xitco & Roitblat's (1996) study, the eavesdropping dolphin was prevented from echolocating by having the melon positioned out of the water; thus whether or not an eavesdropping dolphin 'normally' remains silent when eavesdropping was untested. Silence is, nonetheless, hypothesized to be integral to echoic eavesdropping. Maintaining silence may prevent compromising the eavesdropping dolphin's biosonar system by reducing the number of echolocation signals present during investigative tasks. Silence may also have evolved as a strategy to reduce various costs associated with echolocation production: energetic costs, and detection by prey, predator or conspecifics. The results of the tests for H1 involving silence are available in Chapter 4.

Concerning position: maintaining head alignment is assumed to be necessary in order to reduce distortion of off-axis echoes. It has been shown that the spectral components of the echolocation receiving beam pattern differ considerably at various points along the horizontal and vertical axes (Au, 1993; Au & Moore, 1984). Therefore, if an eavesdropping dolphin is to receive echoes that are the most comparable to the echoes received by the investigating dolphin, maintaining horizontal and vertical head alignment is necessary. Additionally, according to the hypothesis, in order to receive comparable echoes, an eavesdropping dolphin must be positioned in close proximity to the investigating dolphin. Given the results of the Xitco & Roitblat (1996) experiment, and other

speculation as to appropriate listening positions (Götz *et al.*, 2005; Kuc, 2002), a more precise description of the 'ideal' echoic eavesdropping position must be constructed. Details of this position model, as well as results of the tests for both H2 and H3 are available in Chapter 5.

A variety of individual tests and test questions were developed to address all possible contingencies and constraints imposed by each of the three hypotheses. This study involves only one observational investigation scenario, comprising one very specific behavioral context that is assumed to elicit echoic eavesdropping behavior(s). It should be noted that, given the many questions that surround echoic eavesdropping, this study provides but one small piece of the puzzle – there is much room left for further observational and experimental research.

As described earlier, the second aim of this study was to provide insight into the relationship between echoic eavesdropping, and the results of joint attention and referential pointing experiments involving dolphins. A novel cognitive model for joint attention in dolphins will be presented; bimodal joint attention (section 2.3), following from an extended review of this subject in section 2.2. The results achieved for the tests of the three hypotheses have direct impact on a discussion of joint attention in dolphins, as will be discussed in Chapter 6. This discussion will highlight the usefulness of the novel cognitive model, as well as the novel alternative 'multi source echoic eavesdropping', which is presented and discussed in Chapter 6; a direct result of the findings as derived from this study.

Chapter 2 Echoic Eavesdropping and Related Psychological Concepts

2.1 Echoic eavesdropping

The echoic eavesdropping hypothesis for dolphin species proposes that a dolphin may not transmit any echolocation clicks of its own, but rather listen to the echolocation clicks and click echoes produced by conspecifics in order to gain information about its environment. This hypothesis was developed out of a series of suggestions and early hypotheses concerning the possibility that dolphins listen to each other's echolocation in order to obtain environmental and object information. The following sections will provide a review of the development of the hypothesis, detail the experimental and observation support for the hypothesis, as well as consider a variety of problems with the hypothesis itself.

2.1.1 *Overview of a dolphin's biosonar transmission system*

To properly describe the modern version of the echoic eavesdropping hypothesis, a brief description of the relevant components of the biosonar system is required. A dolphin is able to produce an echolocation click by metering a stream of pressurized air across the phonic lips contained within the MLDB (monkey lips dorsal bursae) complex; a system of sacs and tissues in the cranial cavity designed to regulate air flow (Cranford & Amundin, 2004). This sets parts of the complex and surrounding tissues in vibration, generating a series of broadband clicks. These clicks then propagate in a forward direction, guided by the structure of the dolphin cranium and the presence of a lipid-filled organ called the melon located anterior to the nasal complex (Au, 1993). For the most well studied species, the bottlenose dolphin (*Tursiops truncatus*), the click itself comprises broadband frequencies ranging from 30 to 135 kHz (Au, 1993), is of short duration (50 to 70 μ s) (Au *et al.*, 1988), and can be quite loud at \sim 220 dB re 1 μ Pa at 1m (Au, 1993). This results in the formation of an acoustic beam projected forward and approximately 5° upwards in the vertical plane relative to the axis of the rostrum (Au *et al.*, 1986). The beam is highly directional becoming more directional (narrow) as frequency increases with both the horizontal and vertical beam at -3dB measuring \sim 10° for at 120 kHz (Au *et al.*, 1986).

Click repetition rates have been recorded as high as 1,750 pulses per second (Blomqvist, C. personal communication, 2006), however, clicks generated more rapidly than \sim 250 to 300 pulses per second may be ineffective for echolocation tasks (Au *et al.*, 1988; Dubrovsky, 2004), although they may serve a social function (Herzing, 2004). The acoustic beam is directed at a target, generating acoustic reflections and click echoes. The interaction of the transmitted clicks with the surfaces and structures of the target will yield reflections with discernable components comprising an echo structure. The variable components of this echo structure include frequency spectra, peak frequency, echo arrival time intervals, and amplitude, and are affected by variables like target range, size, shape, composition, movement, thickness, and aspect (Au, 1993). A multitude of experimental tests have shown that

dolphins can analyze changes in the variables from echo structure to accomplish target detection, discrimination, recognition and classification (Au & Hammer, 1980; Au & Turl, 1991; Au *et al.*, 1988; Dankiewicz *et al.*, 2002; Helweg *et al.*, 1996a; Nachtigall, 1980; Pack *et al.*, 2002). The algorithms and acoustic computations aiding this process are still poorly understood (Roitblat, 2004), and represent an ongoing challenge to acousticians and psychologists. A dolphin is able to facilitate this process by manipulating a variety of factors in the production, transmission and reception of the acoustic beam. This includes pulse repetition rate, source energy levels, and frequency components (Cranford & Amundin, 2004; Popper, 1980). There does appear to be a coupling between frequency and source level (Madsen *et al.*, 2004), as well as target range and source level in the form of an automatic gain control; this may not be under the voluntary control of the dolphin, but none the less facilitates increased sonar efficiency (Au & Benoit-Bird, 2003). Dolphins also actively alter the position of their head and jaw across the horizontal and vertical planes during active scanning, presumably to manipulate echo structure and aid in discrimination (Herzing, 2004; Kellogg, 1970). Tests of a dolphin's discrimination ability have revealed that echolocation may be functionally equivalent to vision, as revealed in cross-modal matching experiments (Harley *et al.*, 1996; Herman & Pack, 1992; Pack & Herman, 1996). In low light levels, echolocation is likely to be a dolphin's primary sense.

2.1.2 The development of the echoic eavesdropping hypothesis

The nature of the dolphin biosonar transmission and reception system inspired speculation early on as to its usefulness in allowing dolphins to eavesdrop on the echolocation activity of conspecifics. Caldwell and Caldwell (1977) suggested that dolphins would be alerted to the presence of a food source by monitoring the echolocation signals of conspecifics. An analogous situation is found in bats; echolocating Microchiroptera species appear to monitor and respond to the echolocation signals of conspecifics and sympatric species as a means of locating feeding sites (Balcombe & Fenton, 1988; Barclay, 1982). The bats' responses seem predominantly cued to 'feeding buzzes', indicative of the presence of prey by bats actively involved in feeding. This process is not unlike traditional definitions of eavesdropping (see Bradbury & Vehrencamp, 1998), and is not exclusive to echolocation as such.

Later speculation considered the possibility that an eavesdropping dolphin may receive more detailed information from the outgoing click than simply being alerted to the presence of conspecifics or prey species. Penner (1988) discovered a predictable relationship in detection experiments between the distance an echolocating dolphin was to a target and the time delay between the dolphin's echolocation clicks. This inter-click interval was stable enough to allow a human researcher to determine the distance at which a dolphin was concentrating echolocation searches simply by monitoring outgoing clicks. Presumably, other dolphins should be capable of similar range estimations when monitoring the outgoing echolocation of conspecifics either by relying on echolocation computations or by simple learned associations.

An early test of a dolphin's ability to extract information exclusively from echoes was performed by

Scronce and Johnson (1976) who required a bottlenose dolphin to report the presence or absence of a 7.62 cm diameter steel sphere. The dolphin was prevented from emitting echolocation clicks of its own by covering the melon with an acoustically impenetrable mask. An artificial click projector was used to ensonify the sphere with pulses resembling natural dolphin clicks, resulting in echoes that the dolphin could use to determine the presence of the sphere. The sphere was ensonified at distances of 40 m and 80 m, with correct target detection by the dolphin well above what would be expected by chance for both distances. Detection must have been accomplished on the basis of information the dolphin received from the target backscatter. Scronce and Johnson concluded that a dolphin is able to detect and report the presence of an object by listening for the occurrence of target echoes that do not originate from its own biosonar.

In his discussion of dolphin perception, Jerison (1986) introduced essential components of the modern version of the echoic eavesdropping hypothesis. His discussion focused on speculation as to the nature of the dolphin's perceptual world (its '*Umwelt*'), and its relationship to echolocation. Linking echolocation to human language, psychological concepts of 'self' and implicating echolocation in a 'communal mode of reality' for dolphins, Jerison's arguments rely heavily on psychological conjecture. At the core of his more esoteric ideas was a proposal that dolphins may share information by listening to the echolocation activity of other dolphins. Inspired by Fenton's (1980) description of echolocation eavesdropping in bats, Jerison suggested that the echolocation signals and their echoes would provide eavesdropping dolphins with object information similar, if not identical, to the information received by the sender. In contrast to earlier speculation, this idea opened a new avenue for exploring eavesdropping – one where echoes might provide an eavesdropper with detailed information about the environment and objects in that environment.

Dawson's (1991) article concerning vocal communication in Hector's dolphins (*Cephalorhynchus hectori*) introduced a more formalized version of the echoic eavesdropping hypothesis, which he referred to simply as the 'eavesdropping' hypothesis. Much of Dawson's argument focuses on a suggestion for a communication system for Hector's dolphins that does not rely on frequency modulated and unmodulated pure tone 'whistle' structures, but rather on pulsed sounds as a mode for communication. Hector's dolphins are a non-whistling species, and Dawson's hypothesis was largely in response to the suggestion by Herman and Tavolga (1980) and others that whistles are the primary mode of communication for delphinid species. Herman and Tavolga (1980) had, however, pointed out that the suggestion that pulsed sounds are never the primary mode of communication for delphinid species may be unjustified and premature given that pulsed sounds for non-whistling species were likely to be an important form of communication, especially in light of the then existing evidence for burst-pulse sounds used in social interactions (the authors cited Bastian, 1967; Caldwell & Caldwell, 1977 as providing examples).

Dawson (1991) proposed that dolphins can detect the presence of conspecifics by listening to swimming sounds (passive listening), find food by listening to the echolocation activity of other

dolphins (similar to ‘classical eavesdropping’), but also “detect and interpret the echoes of each other’s sonars”. Based on Johnson’s (1988) description of bionic sonar systems that do not require ‘knowledge’ of the outgoing signal, Dawson suggested that click echoes alone would provide the eavesdropper with detailed object information. This unintentional transfer of information between individuals, although not falling within traditional definitions of social communication, is the basis for Dawson’s suggested communication system for Hector’s dolphins.

Taken together, these early suggestions concerning a dolphin’s potential ability to discern object information by listening to the echolocation activity of conspecifics form what can be termed the ‘modern echoic eavesdropping hypothesis’ (Caldwell & Caldwell, 1977; Dawson, 1991; Jerison, 1986; Penner, 1988; Scronce & Johnson, 1976). The hypothesis could be formulated as follows: a dolphin in an appropriate listening position relative to an actively echolocating conspecific or conspecifics is able to receive and utilize detailed object and environmental information from the generated click echoes. With the exception of the two studies described in the following section, few data have been collected to test this hypothesis.

2.1.3 Experimental and observational support

The first and only experimental test to date to focus on the echoic eavesdropping hypothesis was conducted on two Atlantic bottlenose dolphins (*Tursiops truncatus*) housed at the Living Seas, Epcot (Xitco & Roitblat, 1996). Inspired by the hypotheses offered by Dawson (1991) and Jerison (1986), Xitco and Roitblat designed a series of experiments meant to test for ‘passive echolocation object recognition’. It was assumed that the echo features most important to the eavesdropping dolphin are those that are most similar to the echo features available to the echolocating dolphin. Therefore, the two dolphins were positioned close together along the same axis to reduce distortion of off-axis echoes, in view of the fact that the spectral components of the receiving beam pattern differ considerably at various points along the horizontal and vertical axes (Au, 1993; Au & Moore, 1984). Additionally, Xitco and Roitblat suggested that if the eavesdropping dolphin was able to recognize objects by listening to the echoes generated by the inspecting dolphin’s echolocation, it would imply that the eavesdropper does not need to produce echolocation clicks of its own in order for its own echo processing to occur, as has been suggested for both echolocating bats (Razak *et al.*, 1999; Suga, 1990) and dolphins (Dubrovsky, 2004).

In the Xitco and Roitblat experiment, an eavesdropping dolphin was positioned at a bite plate with its melon held above water, making it impossible to transmit echolocation clicks because of the impedance mismatch between air and water. The inspecting dolphin was positioned underneath the eavesdropper, and was allowed to inspect objects using echolocation, the click echoes of which were available to the eavesdropping dolphin. In a variety of trials in a series of two experiments with both familiar and unfamiliar stimulus objects presented behind a visually opaque but echoically transparent screen, the eavesdropper and the inspecting dolphin performed a match-to-sample task. Overall, the eavesdropper performed significantly above chance level with accuracy that closely reflected the

performance of the inspecting dolphin. This is strong evidence that a dolphin is able to extract object information by processing the echoes generated by the echolocation activity of conspecifics.

The only observational test of the echoic eavesdropping hypothesis in wild dolphins so far reported is that by Götz *et al.* (2005). These authors suspected that the tight swimming formations and synchronous swimming behavior exhibited by rough-toothed dolphins (*Steno bredanensis*) could actually be a strategy meant to facilitate echoic eavesdropping. Based on the assumption that close swimming proximity and silence is necessary for dolphins to acquire useful information from the returning click echoes generated by conspecifics, they tested to see if there was a correlation between synchronous swimming and reduced group echolocation production. Their study found that of 80% of the synchronous swimming sequences recorded, only a single dolphin appeared to be echolocating. In the sequences where asynchronous swimming was recorded, there was always more than one dolphin echolocating. The putative ‘eavesdropping’ dolphins in the synchronous swimming scenario were assumed to be able to listen to and process the pulse–echo pairs; that is, both the outgoing click and returning click echo generated by the actively echolocating dolphin. This then would have provided the eavesdropping dolphins with useful target information – resulting in concomitant behaviors: such as maintaining close swimming proximity, alignment, and not producing echolocation signals of their own. This observational study was the first of its kind to provide evidence to suggest that dolphins may engage in echoic eavesdropping behaviors in the wild.

2.1.4 Influence of the hypothesis

With only one experimental and one observational study of the echoic eavesdropping hypothesis reported in the literature to date, the idea is still largely untested. Nonetheless, there has been ample speculation as to how the potential for echoic eavesdropping may manifest itself in the behavior of dolphin species. As described earlier, synchronous behavior may be a strategy employed by dolphins in order to maximize received echo information generated by conspecifics (Götz *et al.*, 2005; Kuc, 2002; Xitco & Roitblat, 1996). Others have suggested that echoic eavesdropping may influence swimming formations used during foraging (Janik, 2005). Norris and Dohl (1980) discussed how echolocation by a group of dolphins may result in ‘shared information’ and ‘sensory integration’, concepts similar to, and perhaps facilitated by, echoic eavesdropping. This ‘sensory integration’, including the rapid transmission of acoustic sensory information between members of a group, has also been discussed by Fellner *et al.* (2006). Herzing (2006) discussed the need to understand echoic eavesdropping and its relationship to swimming positions as it relates to the analysis of shared cognitive information. Group echolocation strategies (including echoic eavesdropping) must then lead to social behavior that dictates which dolphin echolocates and when, possibly resulting in echolocation ‘emission rules’ like those discussed by dos Santos and Almada (2004). Echoic eavesdropping behavior may influence the social hierarchies and the rotating social roles that facilitate shared echolocation duties suggested by Johnson and Norris (Johnson & Norris 1986; Johnson & Norris, 1994). The relationship between echoic eavesdropping, shared information, group synchrony, and a dolphin’s proposed ability to utilize complicated cognitive processes related to a Theory of

Mind have been discussed by Harley *et al.* (1995). It has been suggested that the echelon swimming position commonly seen for mother-calf pairs may facilitate echoic eavesdropping, and possibly provide immature dolphins an opportunity to develop echolocation skills (Herzing, 2004). Finally, echoic eavesdropping has been implicated as a major component of conceivable communication systems for odontocetes (Dawson, 1991; Jerison, 1986).

This study focuses on testing the echoic eavesdropping hypothesis through observations of wild dolphin behavior. Combining parameters derived from earlier forms of the hypothesis with the results of experimental and observational test, as well as predictions generated from subsequent discussions, this study aims to distill a coherent testable hypothesis (hypotheses) from the above assembly of ideas and predictions (see section 1.3). However, given that the echoic eavesdropping hypothesis is still in the very early stages of development, there are a multitude of conceptual problems that warrant a discussion at this stage; the problems will be re-visited in Chapter 6 in light of the results of this study.

2.1.5 *The listening position problem*

It is not clear what listening positions provide an eavesdropping dolphin with sufficient echolocation detail to facilitate object detection, identification, classification, and discrimination. In their experiment, Xitco and Roitblat (1996) noted that the eavesdropping dolphin often “slid along the bite plate to position himself even closer to the inspector”, presumably to increase the quality of the received echo information. It is assumed that the closer the eavesdropper is to the axis of the investigator’s (term ‘investigator’ equivalent to Xitco and Roitblat’s term ‘inspector’) beam, and the closer the two dolphins are to each other on the whole, the more useful the received echoes will be for the eavesdropper, as the information will likely be ‘comparable’ to that of the investigator. Furthermore, the closer the eavesdropper is to the investigator, the higher the received level of the echo returns will be. ‘Comparable’ in this sense implies that the investigator is, by default, always in an optimal listening position, and that the closer an eavesdropper is to this position, the better the echo-information will be. This, however, might not be the case. Xitco and Roitblat (1996) point out that ‘comparable’ information might not be essential for the eavesdropper to glean sufficient information from the echoes in order to acquire ‘useful’ object information. Any variety of listening angles relative to the investigator and the object might yield echo structures that are of use to the eavesdropper. Scronce and Johnson’s (1976) experiments revealed that echoes received from an object being ensonified at oblique angles and originating 80 m from an eavesdropping dolphin nonetheless produced enough echoic information for the dolphin to perform basic detection tasks (i.e., to report if it heard reflected acoustic energy or not).

The propagation of click echoes vis-à-vis the contours and composition of the ensonified object must also be considered when conceptualizing efficacious listening positions. Echo structures vary considerably depending on the structural makeup and relative aspect of the target (Au & Hammer, 1980; Helweg *et al.*, 1996b). Therefore, a scenario wherein the bulk of the reflected energy generated from an investigator’s transmitting beam might be directed at an angle away from her own receiving

beam can be constructed. A dolphin ensonifying a highly reflective flat surface at an oblique incident angle will have the bulk of the energy from that beam directed away from her position along the angle of reflection, and little energy will be contained within the investigator's receiving beam. This creates a scenario wherein the investigator's received echoes will not contain as much energy as those received by a potential eavesdropper positioned on-axis along the angle of reflection some distance away from the investigator. Would this mean that the eavesdropper is receiving 'better' echoic information from the investigator's echolocation signals than the investigator? An eavesdropping scenario must then take into account all of the potential reflective properties of the environment including surface and substrate reflections and reflections created by highly variant object structures and aspects. One problem with this sort of speculation is our lack of knowledge as to what exactly a dolphin requires from an echo structure in order to glean useful object information. Perhaps the above scenario would not facilitate eavesdropping, as the echo structure with 'more energy' overall may not be as useful to the dolphin as other features in the echo structure. The question as to what type of echo structure is 'useful' to a dolphin depends on the nature of the experimental task, or the demands of a specific ecological scenario. In some scenarios, what is 'useful' may simply be an ability to detect enough backscatter energy to determine the presence of an object, as in the Scronce and Johnson experiment. For other scenarios, an ability to discriminate between different types of objects is required, as in the Xitco and Roitblat experiment. Perhaps in natural foraging situations, groups of dolphins do not require ideal discrimination performance from an echoic eavesdropping scenario (e.g., I detect a cod/I detect a salmon) as often as simple detection performance (e.g., I detect nothing/I detect something).

Currently, it is not known how variations in listening position might affect discrimination or detection performance. Additional experimental tests might reveal that any number of listening positions could produce similar discrimination performance results for the eavesdropper. If echoic eavesdropping can occur at distances beyond the current constraints of the hypothesis, it may not be necessary to limit our search for potential eavesdropping behaviors to tightly spaced synchronous events as described by Götz *et al.* (2005). Furthermore, echoic eavesdropping might occur over larger distances if dolphins require only basic detection as opposed to complex discrimination.

2.1.6 The off-axis problem

The listening position problem is further complicated by the unknown role that lower frequencies (i.e., < 60 kHz) found in the 'off-axis' portion of the transmission/receiving beam play in the performance of the dolphin's biosonar. The many experiments testing a dolphin's ability to detect, recognize and classify objects based on their echo structure have led to the conclusion that 'the use of broadband short-duration transient-like sonar signals that can encode important target information also plays an important role in the dolphins' discrimination capabilities' (Au, 1993). Given that, for healthy individuals, the majority of spectral energy and peak frequencies for many dolphin species occur in the higher frequencies (i.e., > 60kHz, Au, 1993), it has previously been assumed that these higher frequencies are critical to the process of object discrimination. There are obvious theoretical benefits

for a wideband echolocation signal in helping to reduce target ambiguity in general (Altes *et al.*, 2003). Higher frequency sounds with shorter wavelengths are required in order to promote reflections and minimize refraction around smaller objects and object features. A 150 kHz tone (pulse) for example should be appropriate for resolving a sphere with a radius of 1.55 mm (Tyack & Clark, 2000). Given that the highest echolocation frequencies are contained exclusively within the on-axis portion of the transmitting beam, the usefulness of the off-axis beam (containing lower frequencies) for object recognition or discrimination has been called into question. Based on Au's (1993) work with directional hearing, Madsen *et al.* (2004) concluded that "while the off-axis part of sonar clicks may play an important role in eavesdropping by conspecifics, predators, and prey, it has probably little relevance to the performance of the sonar."

The echoic eavesdropping hypothesis is constrained by the assumption that an eavesdropper must have on-axis access to these high frequency click echoes, as described by Xitco and Roitblat (1996). A dolphin's echolocation transmission beam is highly directional becoming more directional (narrow) as frequency increases with both the horizontal and vertical beam at -3dB measuring $\sim 10^\circ$ at 120 kHz (Au *et al.*, 1986). The receiving beam is also highly directional, with the vertical beam at -3dB measuring $\sim 10^\circ$ at 120 kHz, and the horizontal beam at -3dB measuring $\sim 14^\circ$ at 120 kHz (Au, 1993). Given these narrow beam patterns for high frequencies, this would suggest that dolphins in an eavesdropping scenario need to be positioned close together for optimal discrimination performance, assuming optimal discrimination requires access to undistorted frequencies at ~ 120 kHz.

The dependence of improved object discrimination on the use of clicks with high frequency energy peaks, however, has not been established. In a summary of various experiments concerning frequency spectra and investigative tasks, Au (1993) noted that dolphins do not appear to alter frequency components of their outgoing clicks in response to targets with features varying in complexity. The broad changes in frequency spectra that have been recorded for echolocation from individual dolphins seem more closely associated with changes in source level to compensate for noise and masking rather than discrimination difficulty. Madsen *et al.* (2004) suggested that centroid frequency is a more robust indicator of spectral components vital to dolphin sonar. Often, this lower center frequency tends to remain stable despite source level changes (Au & Würsig, 2004). Furthermore, the large variation for typical peak frequencies (ranging from 5 kHz to 160 kHz (Au, 1993)) across species does not seem to be correlated with an increase or decrease in discrimination ability. Tyack and Clark (2000) pointed out that although often suggested (see for example Au & Würsig, 2004), there does not appear to be a clear correlation between body size of the odontocete and peak frequency, nor prey size and peak frequency, as had been previously suggested (see Li *et al.*, 2005).

A potentially vital theme was discussed by Tyack and Clark (2000) concerning the notion that the majority of the biological targets that dolphins will encounter in 'real life' situations (i.e., fish or organisms in the deep scattering layer) will contain gas-filled organs or other structures with much lower resonant frequency characteristics than the artificial targets used in experimental tests. Many of

these structures will respond best to the lowest frequencies emitted by an echolocating dolphin, allowing the possibility that dolphins may use lower frequency echolocation for detection of these types of targets. This ambiguity could lead to speculation that the higher frequencies present in the click spectra could aid in discrimination, but are not essential for it to occur. It has not been ruled out that the lower frequencies contained in an echolocation click and its corresponding click echo can provide a dolphin with ‘adequate’ object information. Herzing and dos Santos (2004) suggested that “although echolocation is traditionally thought of as high-frequency sound production, high frequency sound is not essential for echolocation”.

The central problem in this debate is an inability to characterize what ‘adequate’, ‘useful’, or ‘detailed’ object information is for a dolphin’s echolocation process. If we accept that higher frequencies are capable of providing dolphins with better object detail, at what point does a lack of high frequency echoes lead to an inability to detect or identify an object or its features? Large objects like the ocean floor, surface, or rock outcroppings will certainly respond easily to the lowest frequencies in an echolocation click. It seems likely then that a dolphin could detect and classify these biologically relevant targets without using high frequency clicks. Does this mean that a dolphin’s off-axis beam containing limited high frequency energy but ample lower frequency energy could be used to gather ‘useful’ environmental and target information from large targets? The findings of a recent study by Akamatsu *et al.* (2005) support this notion. The authors recorded echolocation signals from the free-ranging Yangtze finless porpoise (*Neophocaena phocaenoides asiaeorientalis*) using a stereo acoustic data logger. It was calculated that the porpoise was capable of receiving surface echoes from the off-axis portion of its beam at depths of 50 m. Moreover, Akamatsu *et al.* estimated that a porpoise would be able to detect a 10 cm fish positioned 3 m above herself using the off-axis portion of her echolocation beam with energy at 38 kHz. Not only does it appear that the porpoise is capable of receiving very general information concerning the location of large targets like the surface (useful in orientation) at considerable distance, but the porpoise is capable of resolving the presence of small prey species using lower frequencies from the off-axis portion of their echolocation beam. Presumably, this information might not be ‘detailed’ object information, but it may be considered ‘adequate’ and ‘useful’.

Additional support for the notion that dolphins do not necessarily require higher frequencies for ‘useful’ object information is described in experiments with free-swimming bottlenose dolphins involved in open water search and detection tasks (Houser *et al.*, 2005; Martin *et al.*, 2005). For these experiments, dolphins were fitted with a device capable of recording echolocation clicks and click echoes, as well as swim position. The dolphins were required to report the presence or absence of an object located on the sea floor. One of the two dolphins involved in the experiment had significant hearing loss above 50 kHz, and, consequently, produced echolocation clicks during detection tasks with peak frequencies between 30-60 kHz (Houser *et al.*, 2005). Despite using these ‘lower’ frequencies, the dolphin was successful during these detection tasks. This confirms prior reports that dolphins with profound hearing loss that rely on lower frequency echolocation clicks are, nonetheless,

able to perform well in detection tasks (e.g., Houser *et al.*, 1999; Moore *et al.*, 2004). For these experiments, on-axis clicks with peak frequencies far below the 120 kHz typical for healthy dolphins nevertheless resulted in ‘adequate’ detection ability.

Further eavesdropping listening position experiments will shed light on the problem of where the boundaries lie between ‘adequate’ object information allowing a dolphin to report the presence or absence of an object (object detection), and ‘detailed’ object information allowing for complex object discrimination. If dolphins eavesdrop on the low-frequency echoes propagating in a much wider receiving beam pattern, they may be capable of swimming in widely spaced formation and still be able to receive useful, biologically relevant echo information from conspecifics. In this sense, the off-axis ‘problem’ may in fact be an ‘opportunity’ for a listening dolphin. Unraveling the extent to which dolphins can use this low-frequency off-axis echo information will alter our ideas as to how echoic eavesdropping might manifest itself in the behaviors of wild dolphins.

2.1.7 *The features problem*

Solving both the listening position problem and the off-axis problem will shed light on components critical to our understanding of echoic eavesdropping. However, both of these problems are complicated by a more fundamental issue: it is still not known what features in the returning echo structure are used by either the eavesdropping dolphin or the investigator to perform object discrimination in the first place.

Click echoes are capable of providing a dolphin with considerable environmental and object information, allowing dolphins to perform remarkable perceptual feats beyond simple orientation and obstacle object avoidance tasks (see reviews by Kellogg, 1970; Moore, 1980) and basic object detection (Au & Snyder, 1980; Helweg *et al.*, 1996a). They can distinguish objects based on size, shape, and composition (Au & Hammer, 1980; Au *et al.*, 1980; Nachtigall, 1980), despite changes in aspect (Au & Turl, 1991; Helweg *et al.*, 1996b). Sensory information received from both echolocation and visual modalities is evidently sufficiently comparable to lead to successful object matching across the two modalities, suggesting that echolocation may be functionally equivalent to or better than vision for some object discrimination tasks (Harley *et al.*, 2003; Herman & Pack, 1992; Herman *et al.*, 1998; Pack & Herman, 1995).

How are dolphins able to accomplish these feats? Experimental work has been done to clarify this point, but much uncertainty remains. A few suggested essential features within the echo structure that allow for complex recognition include energy highlights (amplitude differences) for frequency components of individual echoes and across time for the echo train (Au *et al.*, 1988; Dankiewicz *et al.*, 2002; Helweg *et al.*, 2003), general spectral qualities (Johnson, 1980), echo arrival times and time separation pitch (Au & Hammer, 1980; Moore *et al.*, 1984), and click echo and click train duration (Au & Turl, 1991). Suggestions for possible neural processing mechanisms (Johnson, 1980; Popper, 1980), and neural network models (Altes, 1995; Au, 1994; Roitblat *et al.*, 1995) relating to echo

processing have been offered. It appears that dolphins are able to construct global mental object representations based on object shape, contours, and composition from these features contained in the echo structure (Harley *et al.*, 1996; Pack *et al.*, 2002), revealing a high level of complexity in the dolphin's perceptual system (for an overview of the problem see Roitblat, 2004). Despite this experimental work, a comprehensive theory as to how received echo structure stimuli lead to perception has not yet been proposed. It could be said that a search for the germane echo features facilitating object recognition is a red herring, equivalent to constructing a theory of vision in humans based on analysis of retinal processing of light ray stimuli, thus ignoring the 'behind the scenes' processing taking place at higher levels of neurological function resulting in perception. Neurological top-down processing theories might be our only avenue for understanding how object recognition takes place for dolphins, demanding a different computational framework that is "more like a dynamic system than like a standard computation algorithm", as Roitblat (2004) suggested.

Eavesdropping experiments have the potential to tell us not only more about the critical features in the echo structure that are necessary for object recognition, but also to increase our knowledge as to how natural dolphin behavior facilitates echolocation use in general, and to give us deeper insight into the dynamic process of object recognition. For example, movement of the dolphin's head in three dimensions during echolocation inspection tasks increases echo complexity and would be a useful strategy to increase the effectiveness of target resolution. Furthermore, unlike most laboratory experiments, free-swimming dolphins are not required to remain in a fixed swimming position when inspecting a target; distance to the target may vary considerably as the dolphin approaches during inspection (see discussion on free-swimming detection tasks by Houser *et al.*, 2005; Martin *et al.*, 2005). The question arises, therefore, as to whether when the echolocating dolphin changes its head and swimming position relative to the target during inspection, 'predictable' changes in the highlights of the returning echo structure (e.g., changes in peak frequency, number of received echoes) are created, thus facilitating object recognition? If echolocating dolphins employ this strategy when inspecting objects (Altes *et al.*, 2003; Houser *et al.*, 2005), would an eavesdropping dolphin still be able to use this echoic information if she had not initiated the changes in swim and head positions? Given the results of Xitco and Roitblat's (1996) experiment, it appears that an eavesdropping dolphin is able to make use of the information contained in the returning echoes despite the changes in swim and head position initiated by the echolocating dolphin.

An understanding of the echo features necessary and the behaviors facilitating object discrimination by an inspecting dolphin will help to construct a better hypothesis relating to echoic eavesdropping. Beyond simply knowing optimal or sufficient listening positions, understanding what additional behaviors are critical for the process as a whole (e.g., head movement) will allow scientist to better evaluate the behaviors of wild dolphins involved in potential echoic eavesdropping scenarios.

2.1.8 *The outgoing click problem*

For their experiment, Xitco and Roitblat (1996) addressed a secondary debate regarding the extent to

which a dolphin requires knowledge of the outgoing click in order to process echo information. Dubrovsky (2004) argued that outgoing clicks, or signals similar to dolphin echolocation clicks, are necessary for the proper 'activation' of the 'active hearing mode' in dolphins. In this sense, proper echo processing would not be possible without the availability of some manner of outgoing click. This may be analogous to the situation described for echolocating bats, where echo processing can not take place without the information derived from the outgoing click (Razak *et al.*, 1999; Suga, 1990). In contrast to this scenario, the results from Xitco and Roitblat's (1996) experiment suggests that a dolphin does not need to generate her own echolocation clicks to be able to derive object information from an echo structure. This does not, however, exclude the possibility that a dolphin must in some way hear the outgoing clicks of another dolphin in order to properly process associated echo information.

If, in an echoic eavesdropping scenario, the eavesdropper needs to be positioned in such a way as to be able to hear the outgoing click before echo processing can occur, this may again constrain potential listening positions. If the eavesdropper is required to have access to the outgoing click, presumably there are features within the click that are vital to echo processing. It is not known what these features might be (e.g., frequency spectra, amplitude). Perhaps the eavesdropper must be able to match the outgoing click to its echo, as has been suggested by Kuc (2002), possibly restricting the distance at which an eavesdropper can be positioned from an investigator. The role of the outgoing click in an echoic eavesdropping situation remains ambiguous, and is in need of further data for confirmation of its role.

2.1.9 The silence problem

The current hypothesis predicts that an eavesdropping dolphin will remain silent in order to maximize information it can gain from reception of click echoes resultant from the biosonar of conspecifics. Observations of reduced echolocation use by wild odontocetes has led to speculation that echoic eavesdropping behavior could be implicated (dos Santos & Almada, 2004; Götz *et al.*, 2005) and assumes that silence is an integral component of echoic eavesdropping. There are two arguments as to why silence would be correlated with eavesdropping. First, we assume that there are significant costs associated with echolocation production, prompting dolphins to employ strategies meant to reduce the need to use echolocation. Example costs include a metabolic expense or unwanted detection by predators and conspecifics. Thus, eavesdropping is a selfish strategy on the part of the eavesdropper; we would expect dolphins to employ this strategy whenever an appropriate situation presents itself. Second, remaining silent might actually facilitate eavesdropping by reducing the chance that conflicting echoes from two or more click trains will hinder the effectiveness of the echo processing system (i.e., to prevent jamming). I will discuss the strength of these two arguments in turn.

Limited data on odontocete echolocation use in the wild restricts the scope of speculation as to the influence of ecological costs in an echoic eavesdropping scenario, although some benefits to remaining echoically silent have been discussed. Although largely unstudied, predator detection was

deemed unlikely in one study of passive listening in *Tursiops* (dos Santos & Almada, 2004). Also, it is possible that some known dolphin predators (e.g., sharks) would be unlikely to hear echolocation clicks (Gannon *et al.*, 2005). The exception, of course, relates to predation from other echolocating odontocetes. Food competition and the cost of detection by conspecifics have not been studied (Gannon *et al.*, 2005), although Janik (2000) noted that dolphins do respond to echolocation activity of feeding conspecifics. Barrett-Leonard *et al.* (1996) observed that transient, mammal-eating orca (*Orcinus orca*) populations employed a variety of strategies including total silence during prey detection and approach. This is an apparent effort by the group to minimize the costs associated with prey species' ability to detect orca biosonar. It could be argued that costs associated with detection by prey, predators, and conspecifics are irrelevant factors in this discussion given that a silent echoic eavesdropping dolphin will be positioned in close proximity to an actively echolocating dolphin, thus the likelihood of detection will be the same, or similar, whether or not the eavesdropper remains silent. However, it is possible that the summed effect of multiple echolocation signals contributes to higher detection levels by prey, predator, or conspecifics. Still, this increase is likely to be negligible when compared to the effects of the difference between a single individual echolocating and absolute silence from all individuals.

In addition to ecological costs, silence strategies may be influenced by the metabolic expense of echolocation production. There is an energetic cost for the production of echolocation signals; therefore, it is possible that social strategies have evolved that optimize echolocation use for individuals in group situations. Unfortunately, metabolic costs for dolphin biosonar have received limited experimental attention with the exception of a study by Cole and Speakman (1993). Speculation ranges from negligible to potentially significant predicted costs (Au, 1993; Cranford & Amundin, 2004; Gannon *et al.*, 2005; Herzing & dos Santos, 2004; Johnson & Norris 1986; Norris *et al.*, 1994). Further experimental work is needed to clarify the true costs associated with echolocation production before it can reasonably be implicated in the evolution of complex social behavior linked with echoic eavesdropping.

The second argument is that eavesdroppers remain silent in order to prevent sonar 'jamming'. Data collected from some echolocating bat species (e.g., *Tadarida teniotis*, *Tadarida brasiliensis*) suggest that they may employ a jamming avoidance response (JAR) by changing parameters of their echolocation calls (Fenton, 2003), including shifting their dominant frequency when jammed with the calls of conspecifics (Gillam *et al.*, 2007; Ulanovsky *et al.*, 2004). In contrast, studies of other species (e.g., *Taphozous perforatus*) did not find evidence of JAR behaviors (Ulanovsky *et al.*, 2004). JAR has not been studied in marine mammals (Gillam *et al.*, 2007), although suggestions for potential JAR behaviors have been offered for dolphins. For dolphin groups, echolocation 'emission rules' that compensate for too many simultaneous biosonar signals in the water have been proposed (dos Santos & Almada, 2004). The limited observations on wild dolphin populations suggest a negative correlation between group size and echolocation activity: the larger the group, the less relative echolocation use (Barrett-Lennard *et al.*, 1996; dos Santos & Almada, 2004). Götz *et al.* (2005)

reported for their study of *Steno bredanensis* that no more than one animal was recorded echolocating in 80% of recorded synchronous swimming sequences. Additional data collected from free-swimming spinner dolphins (*Stenella longirostris*) revealed minimal concurrent echolocation activity among closely-spaced animals (Lammers *et al.*, 2006). This suggests that if echoic eavesdropping is the cause of the described behavior then a JAR response of limiting outgoing echo trains for the group to a few or just one animal may occur in order to prevent confusing returning echo structures, as Götz *et al.* (2005) point out.

Although the above observations could be interpreted to mean that silence is important to eavesdropping if individual members of these groups are indeed eavesdropping on each other, it also reveals that groups of echolocating odontocetes (with the exception of the study by Götz *et al.* (2005)) are able to echolocate en masse, presumably without affecting foraging effectiveness. If the echo reception process were compromised by the presence of conspecifics' echolocation activity, one would expect to record far less echolocation activity from such groups. Furthermore, experimental studies have also shown that potentially disruptive acoustic activity including noise and reverberation does not have a serious negative impact on dolphin echolocation performance (Au, 1993; Dubrovsky, 2004). Experiments with man-made models have even shown that dolphins should theoretically be able to extract useful target information from multiple biosonar sources (Kuc, 2002). This ambivalence reminds us again that we still do not understand what the salient features in the echo structure necessary for object detection and recognition are. At what point does a combination of click trains emitted from nearby conspecifics hinder an animal's ability to extract necessary object information? Does this number change as a consequence of the type of task at hand (e.g., simple object or obstacle detection vs. acquisition of detailed object information)? Considerably more experimental and observational work needs to be conducted before a clear picture of the sonar jamming problem will emerge for odontocetes.

It is not certain that significant costs, metabolic or otherwise, could be the cause of silent behavior in an echoic eavesdropping scenario - there is insufficient observational or experimental supportive evidence. Nor is sonar jamming convincingly implicated as a problem for odontocetes. It could be argued that silence is putatively inferred as a factor in echoic eavesdropping given its importance to traditional definitions of eavesdropping. For orca, group silence while hunting vigilant marine mammals through passive listening is probably a necessary strategy to avoid detection. However, echoic eavesdropping does not predict group silence in the way that passive listening might, rather it predicts individual silence; as a result these group detection costs seem an inappropriate factor to consider. Intuitively, silence seems a necessary condition for eavesdropping - for example, it is hard to imagine an effective eavesdropping scenario where songbirds can successfully eavesdrop on the songs of conspecifics while themselves singing. These limitations, however, may be misplaced for dolphin species where the presence of simultaneous biosonar signals may not compromise individuals' sonar success, and may even contribute to its efficiency (Kuc, 2002).

2.1.10 *The social problem*

When discussing how echoic eavesdropping might help explain dolphin behavior in relation to echolocation, an additional element that is not related to the performance of the biosonar system must be considered. Some researchers have discussed how social rules and roles may influence the production or suppression of echolocation activity in dolphin groups (e.g., dos Santos & Almada, 2004; Johnson & Norris 1986; Johnson & Norris, 1994). Perhaps echolocation production or suppression may be involved in displays of dominance or fitness, either by an individual, dyads (e.g., male alliances), or smaller groups, wholly divorced from the possible negative or positive impacts on the biosonar system of the individuals involved. Or perhaps, as Johnson and Norris suggest (Johnson & Norris 1986; , 1994), rotating social roles may dictate which dolphin echolocates and when. Complex behavioral accounts involving kin selection, reciprocity, and inclusive fitness may be involved, as has been proposed for explaining geese flight formations (e.g., Andersson & Wallander, 2004). Understanding wild dolphin echolocation behavior may require that we look beyond the mechanics of echoic eavesdropping and take into account social explanations.

2.1.11 *Summary*

Before a clearer picture emerges concerning how echoic eavesdropping might influence behavior in wild dolphin populations, many questions must be answered concerning the function of the mechanisms involved:

- What listening positions are capable of producing useful echo information to the eavesdropper? Must an eavesdropper be positioned close to the investigator?
- Can lower frequencies in the click structure be used by a dolphin for object detection/discrimination?
- What features in the click structure are necessary for object detection/discrimination in general?
- What is the role of the outgoing click for the echolocation system for both an inspecting dolphin and an eavesdropper?
- Can dolphins process echoes resulting from the echolocation of conspecifics in conjunction with their own echolocation? If this is possible, does this decrease or increase target recognition performance?
- What are the metabolic costs for echolocation production? How might other costs influence the eavesdropping behavior of dolphins?

Despite the many potential problems with the hypothesis in its current form, there is clear evidence that the basic, underlying principle of the echoic eavesdropping hypothesis is sound (i.e., that dolphins are able to use backscatter originating from a target echolocated upon by a conspecific in order to accomplish target discrimination, (Xitco & Roitblat, 1996)). The confusion as to what the

manifestations of this behavior may be for wild dolphin species can be found in the details of the mechanisms involved (as outlined in the previous sections). For the purpose of this study, the conceptual hypothesis that has been provided - that dolphins traveling in dyads engage in echoic eavesdropping behaviors when inspecting a target - accepts the constraints suggested by Xitco and Roitblat in their experimental study. These constraints are 1) that the eavesdropping dolphin will remain silent, 2) that the eavesdropping dolphin needs to be in close proximity to the echolocating dolphin, and 3) that the eavesdropper will need to maintain head alignment. Thus, this study has been designed to test predictions relating to these constraints. Negative findings will require that the details of the echoic eavesdropping hypothesis be altered (i.e., possible rejection of the three operational hypotheses used in the study – see section 1.3), though not necessarily that the original hypothesis offered by Xitco and Roitblat need be rejected when applied to wild species. This topic will be covered in more depth in Chapter 6.

2.2 Relevant psychological concepts

2.2.1 Introduction

Echoic eavesdropping has been linked to the concepts of joint attention and referential pointing by numerous authors (Herman *et al.*, 1999; Herzing, 2006; Pack & Herman, 2004; Pack & Herman, 2006; Pack & Herman, 2007; Xitco *et al.*, 2004). Perhaps with the exception of the Pack and Herman (2007) review, these links are not often explored in any detail, remaining as simple suggestions by the authors. What follows here is an attempt to explore more deeply these possible links, with particular emphasis on the cognitive component. In the following section, a comprehensive overview of the possible link between echoic eavesdropping and joint attention/referential pointing will be provided. In order to accomplish this, relevant cognitive mechanisms will be described where appropriate. Ultimately, a novel cognitive model of joint attention in dolphins will be constructed: bimodal joint attention (see section 2.3). This section will serve as an appropriate backdrop to the general discussion concerning how the results of the present study can be related to the idea that echoic eavesdropping consists of a suite of behaviors exhibited by wild dolphins that contributes directly to their aptitude for joint attention and comprehension of referential pointing in experimental situations (section 6.2.3).

2.2.2 Eye direction and gaze following

Perhaps the most basic mechanism facilitating joint attention is the ability to reliably follow the eye direction/gaze of another agent. In relation to eye detection abilities in humans and primates, Baron-Cohen (1995) discusses a mechanism or module termed the Eye-Direction Detector (EDD). This module has three functions: 1) to detect the presence of eyes or eye-like stimuli, 2) to determine the direction of the gaze based on cues from the eyes, and 3) to attribute the mental state of ‘seeing’ to an agent whose eye direction is focused on an object (Langton *et al.*, 2000). The third function of the EDD (to interpret gaze as ‘seeing’) exposes a controversial topic that most authors are reluctant to include in a description of a basic or low-level process, and so I will refrain from discussing this function until section 2.2.3.2. Concerning the first function, examples of eye morphology across taxa

provides clues to the existence of an EDD; a perceptual preference for detecting the presence of eyes may be rather ubiquitous in vertebrates. Many animals appear sensitive to stimuli in the form of eye-like shapes; for example, a small black circle within a larger white circle (Emery, 2005). Morphological adaptations for eye camouflage, including eye banding, obliterative eye-lines, cryptic coloration and patterning, are common in many species of insects, birds and fish (Barlow, 1972). For a predator, camouflaging the eyes is desirable because prey species appear to be particularly sensitive to eye-like stimuli. Conversely, obfuscating the eyes may enable prey species to reduce their chance of detection by a predator that is also tuned to eye-like stimuli. Many species of butterflies and moths are known to have evolved prominent 'eye-spots' (an eye-like stimulus) on their wings as a method of anti-predator defense (Vallin *et al.*, 2005), similar to the anti-predator eyespots found in many species of fish (Beeching, 1993). Concerning sensitivity to eye morphology as evidenced through behavior, gaze aversion when in the presence of eye-like stimuli has been demonstrated in lesser mouse lemurs (*Microcerbus murinus*) (Coss, 1978), jewelfish (*Hemichromis bimaculatus*) (Coss, 1979), various bird species (Jones, 1980), and mice (Topal & Csanyi, 1994). In humans, a preference for looking at the eyes develops within the first few months after birth (Langton *et al.*, 2000; Maurer, 1985), with visual fixation on the eyes of an adult occurring between just 5 and 7 weeks after birth (Haith *et al.*, 1977). Adult humans devote 70% of their visual scanning of a face to the eyes (Pelphrey *et al.*, 2003). Like humans, various primate species also appear tuned specifically to the eyes, as opposed to other facial or anatomical structures of conspecifics (Emery, 2000). In summary, there is a multitude of evidence from evolved morphology and behavior across taxa that suggest the presence of an eye-detection module as described in the EDD.

Concerning the second function of the EDD, behavioral evidence from various species again supports the idea that a perceptual system may be in place that is sensitive to gaze direction information from eye stimuli. Plovers (*Charadrius sp.*) (Ristau, 1991), iguanas (*Ctenosaura similes*) (Burger *et al.*, 1992), chickens (*Gallus gallus*) (Gallup *et al.*, 1972), and lizards (*Anolis carolinensis*) (Hennig, 1977) all exhibit fright, vigilance or escape behaviors when human gaze is fixated on them (or their offspring) as opposed to control situations where human gaze is averted. Experiments with humans show that a wide range of responses are present when a human views conspecific eye-stimuli that is fixated on them ('mutual-gaze') as opposed to another direction; for example, physiological arousal and smiling (Baron-Cohen, 1995). These examples provide evidence that the eyes are in some way 'special' conveyors of information, and that a seemingly widespread eye morphology and gaze detection preference may exist in the visual system of a great many species (not just primates). For humans, eye evolution may have taken a different course to that of other species, related to the importance of eye cues in human communication. Kobayashi and Kohshima (1997) discuss a morphological over-exaggeration of potential directional indicators for the human eye (e.g., distinctive white sclera and dark iris), giving the eye more prominence than would be expected for a predatory or prey species conceivably benefiting from eye camouflage. Compared to the other 88 primate species surveyed in their study, the human eye was unique in its prominent white sclera and dark iris. Emery (2000) has also suggested that the morphology of the human face may have evolved

to emphasize the eyes as an important communicative feature of the human face. Prominent and emphasized eye morphology may be unique to humans, where a relationship between Theory of Mind, language evolution and an EDD may contribute to different requirements for the morphology of the eye; one where reading the eye cues of conspecifics may produce enormous communicative benefits.

2.2.2.1 Reflexive Attention Shifts

An additional mechanism likely underpinning joint attention is a reflexive attention shift mechanism facilitating gaze following. Though not described in the EDD, other authors have discussed reflexive gaze following as a basic low level process (Langton *et al.*, 2000). This behavior has also been labeled ‘visual co-orienting’ (VCO) (Emery, 2005). Evidence that animals are able to engage in gaze following behaviors is plentiful, though, importantly, this evidence does not seem to be limited to information from the eyes. Both head orientation and eye direction cues appear to prompt many species to shift their direction of attention to the same direction as another agent: either a conspecific or a human researcher. Dogs (*Canis familiaris*) (McKinley & Sambrook, 2000; Miklósi *et al.*, 1998), chimpanzees (Call *et al.*, 1998; Povinelli & Eddy, 1996a; Povinelli & Eddy, 1997; Tomasello *et al.*, 1998; Tomasello *et al.*, 1999), goats (*Capri hircus*) (Kaminski *et al.*, 2005), monkeys (Emery *et al.*, 1997; Ferrari *et al.*, 2000; Neiwirth *et al.*, 2002; Vick & Anderson, 2000a), gibbons (*Hylobates pileatus*) (Horton & Caldwell, 2006), orangutans (*Pongo pygmaeus*) (Kaplan & Rogers, 2002), birds (Bugnyar *et al.*, 2004; Ristau, 1991), baboons (*Papio papio*) (Fagot & Deruelle, 2002) and young infants (Scaife & Bruner, 1975) have all exhibited gaze following behaviors. For human infants, reliably following the direction of gaze of an adult emerges between eight and ten months (Carpenter *et al.*, 1998). Dolphins exhibit similar gaze following behaviors in relation to gaze cues (Pack & Herman, 2004; Tschudin *et al.*, 2001); these results will be explored in more detail in section 2.3. While striking, these studies do not provide evidence that a single robust low-level mechanism governs reflexive gaze following. For the above studies, divergent and incongruent experimental methodologies, as well as the influence of human enculturation in the case of primates and marine mammals, and domestication in the case of dogs and goats may have an effect on the results (see discussions by Itakura, 2004; Kaminski *et al.*, 2005; Miklósi *et al.*, 1998; Miklósi & Soproni, 2006). Thus, differences in species’ ability to follow gaze may be a direct result of methodological design and not underlying cognitive processes, making it difficult to extrapolate the presence of a reflexive gaze following mechanism based on this evidence.

Eye morphology and the need for eye camouflage, as well as the gaze aversion studies described above predict/necessitate a visual/perception system that must then be specially designed to both detect the presence of eye stimuli and determine direction of gaze; the first two functions of Baron-Cohen’s EDD. Gaze following experiments also suggest (though do not confirm beyond doubt) that such a mechanism may be present, and that it may trigger certain reflexive behaviors. A myriad of experimental research reports provide more tangible evidence for the existence of such a module within the visual perceptual system of humans and primates, with some evidence at the level of individual neurons. It has been demonstrated that a relatively simple processing mechanism supported

by simple cortical cells will respond to changes in eye direction (Anstis *et al.*, 1969; Langton *et al.*, 2000). The cells in question are tuned to the sclera and the iris and changes in the relative amount of sclera to iris during gaze shifts. As more sclera becomes visible, the cells respond by increasing output. This simple processing mechanism then becomes a powerful and robust tool for responding to changes in eye direction.

2.2.2.2 Neural Correlates of Gaze Following

It has been proposed that a mechanism resulting in spontaneous gaze shifts when presented with eye-like stimuli (as described above) could be mediated by cells in the superior temporal sulcus (STS) tuned specifically to eye stimuli (Emery, 2000). Various studies have demonstrated reflexive gaze shifts in response to averted eye stimuli in both humans and primates (Deaner & Platt, 2003; Kingstone *et al.*, 2000; Kingstone *et al.*, 2004; Ricciardelli *et al.*, 2002). Studies of cells in the primate cortex reveal that cells in the STS and the inferior temporal (IT) cortex responded to a variety of facial stimuli (eye, nose, mouth, etc.), with varying response strength as facial features are distorted. Some cells in the STS however responded consistently to eye stimuli regardless of other facial cues, although many cells responded to a combination of head orientation and eye direction (Perrett *et al.*, 1990; Perrett *et al.*, 1992; Puce *et al.*, 1995). Kingstone *et al.*'s (2000) study, in which split brain patients were presented with various eye and face stimuli, revealed that the reflexive response to eye stimuli was localized to the hemisphere specialized in processing upright faces (opposite hemispheres in the case of each of the 2 split brain subjects in this experiment). Interestingly, this indicates that the eye detection mechanism operated regardless of the orientation of the face, suggesting that the STS cells function independent of the IT cells used in face processing. These and other studies (Hooker *et al.*, 2003; Kingstone *et al.*, 2004; Yamane *et al.*, 1988) strongly suggested that there is a set of cells in the STS tuned exclusively to eye cues/gaze. However, others propose that the full gaze following mechanism may rely on cells in the STS in combination with cells in the IT, orbitofrontal cortex cells, right fusiform gyrus, bilateral prefrontal cortex, and the amygdala (Eacott *et al.*, 1993; Hooker *et al.*, 2003; Kawashima *et al.*, 1999). Evidence from autistic spectrum disorder patients further confirms that an interaction of brain regions contributes to gaze processing. Although autism affects numerous areas of the brain including the cerebellum, brain-stem, frontal lobes, parietal lobes, hippocampus, etc. (Baron-Cohen, 2004), specific areas have been identified as contributing directly to gaze following deficits, including the amygdala (Baron-Cohen *et al.*, 1999b), the medial frontal cortex (Baron-Cohen, 2004), and the orbitofrontal cortex (Baron-Cohen *et al.*, 1995; Stone *et al.*, 1998). The amygdala in particular has been shown to be sensitive to eye gaze in monkeys (Leonard *et al.*, 1985) and humans (Kawashima *et al.*, 1999).

Although certain cells in the STS may respond exclusively to eye direction cues, likely mediating reflexive gaze shifts, it is clear from the above experiments that the eye direction processing system involves a variety of modules incorporating other facial and body cues, possibly located in a range of locations in the brain. Whereas Baron-Cohen's EDD module appears to limit its responsiveness to eye-direction cues alone, other models incorporate the interaction of areas dedicated to eye-direction

with areas involving head, face and body cues. Following their work focusing on single cells within the STS, Perrett and his colleagues (Perrett & Emery, 1994; Perrett *et al.*, 1992) posit a module termed the ‘direction-of-attention detector’ (DAD). The STS cells in these studies responded to heads oriented in different direction, as well as body postures, though the information routed from the eyes for these cells appeared to ‘override’ other information should the head and body postures be in conflict with the eye direction. Thus, the DAD, while giving priority to eye direction information, functions in combination with other directional cues. This broadens the scope of the EDD proposed by Baron-Cohen. However some neurophysiological findings from other studies call into question whether the DAD module has gone far enough in describing the importance of additional cues to any proposed eye detection module. Studies by Langton and colleagues (Langton, 2000; Langton *et al.*, 2000) suggest that the eye direction module may in fact combine head direction and other cues (e.g., pointing gestures) in parallel with eye direction cues without giving priority to eye-direction cues. For their experiment (Langton *et al.*, 2000), human subjects were incapable of ignoring head cues (as evidenced by slower reaction times) when asked to follow eye gaze stimuli in combination with head direction stimuli.

That animals (including humans) possess some form of eye-detection module limited exclusively to processing information from the eyes is probable, with substantial evidence that some neurons are indeed tuned to eye cues. However, real-world gaze detection behaviors may rely on a combination of gaze and postural cues (Emery, 2000). It is important to note that eye cues need not always be inevitably introduced into a discussion of gaze following – for some situations and for some species, other directional cues may play a prominent or exclusive role in directing attention of an agent. For example: tails, head crests, and horns may all act as directional cues of attention for species where processing eye cues is not a priority (Bertrand, 1969; Emery, 2000; Hinde & Rowell, 1961; Zahavi, 1997). Although eye cues are a vital component of many authors’ proposed gaze following modules (as highlighted by the above discussion), these proposed mechanisms and modules (e.g., EDD) may have failed to address the importance of non-eye cues in directing attention for some species (see discussion by Langton *et al.*, 2000). The neurophysiological evidence seems to point to an attention detection modules organized even at the level of a single neuron, but this module (likely resulting in spontaneous and reflexive shift in attention) may actually involve disparate cognitive processes in species where eye cues or vision are not as central as they may be in primates. The results of studies describing attention detection in animals may be biased toward eye and vision detection given that primates feature so prominently as study subjects. Thus, for animals displaying ‘gaze following’ behaviors at this basic level, an ‘attention detection module’ is likely to be present, though it likely incorporates a variety of attentional cues (e.g., eyes, postures, etc) as proposed and discussed by Perrin and Emery (1994), and Langton (2000) . The addition of cues in modalities other than vision (e.g., auditory cues in combination with visual cues) is known to enhance the gaze following behaviors of primates (Emery, 2005). This point is especially important to a discussion of dolphins and echoic eavesdropping, as eye cues are unlikely to play a major role in direction of attention shifts (see section 2.3.2.1).

An important final note: for any proposed ‘attention detection module’ (e.g., EDD, DAD), Theory of Mind or other abilities resulting in the attribution of mental states to another agent are not inevitable emergent features. Although Baron-Cohen (1995) explicitly describes the subject’s attribution of the mental state of ‘seeing’ to the other agent (a precursor to Theory of Mind) as the third function of the EDD module, this ability is not necessary for adequate function of an ‘attention detection module’ at the level being described here. Subsequently, I have not addressed this function. I would argue that this ability, if present at all, would more likely be found at a mid-level of processing as part of joint attention ‘proper’, and not simple eye, gaze or attention detection. All mechanisms and underlying neurophysiology functioning at the level of, for example, eye-direction, do not require mental-state attribution to function or to produce the simple reflexive behaviors described in the preceding human and animal studies. There is, however, evidence at the neurophysiological level that processing mechanisms relevant to mental state attribution may be described in terms of single cell function. Similar to the single cells described in the STS that are tuned to eye cues, other single cells exist in the cortex that are tuned to stimuli that may be directly relatable to Theory of Mind. These recently discovered ‘mirror neuron’ cells, and their relationship to joint attention, will be described in section 2.2.3.7.

2.2.3 Joint attention

Moving beyond gaze or attention following, and towards joint attention, requires that the subject do more than simply follow gaze or attention to a location in space. A low-level attention following process will create reflexive shifts of attention that will function in orienting the subject to a location based on the eye cues of another agent, with the benefit that something of interest might be found there (Corkum & Moore, 1998). Starting between 10 and 15 months (Carpenter *et al.*, 1998), and undoubtedly by 18 months, a human infant will follow the direction of gaze cued by eye movement alone, ignoring other cues (e.g., head orientation) (Brooks & Meltzoff, 2005), and focus on the other agent’s focus of attention, that is, the object (Morissette *et al.*, 1995). The gaze perception skill-set that results in joint attention develops in various stages, as argued by Butterworth and Jarrett (1991). Having moved from stage 1) co-orienting in the same general direction as the agent (6 months of age), to stage 2) being able to localize a particular object that is the focus of attention of the agent (12 months), an infant will ultimately be able to follow the direction of attention of an agent to an object outside its field of vision (stage 3) (see review by Povinelli & Eddy, 1996a). For animal species, both head orientation and eye cues allow many primate species to be cued to a specific object (Call *et al.*, 1998; Inoue *et al.*, 2004; Itakura & Anderson, 1996; Povinelli *et al.*, 1999). The introduction of the object into this process creates a triadic relationship that has been described as shared attention, simultaneous attention and joint attention. There is no consensus in the literature as to what each of these terms entails; either in terms of underlying cognitive processes or observable behavioral outcomes. I will therefore adopt a convention for this review, and attempt to describe the views of various authors in relation to these terms. I will subdivide the ambiguous term ‘joint attention’ into two distinct terms; ‘simple triadic attention’, and ‘rich joint attention’. ‘Simple triadic attention’ can

be described simply as a subject and agent focusing attention simultaneously on the same object. Rich joint attention describes the same triadic relationship, but assumes richer cognitive processes underpin the establishment and maintenance of this triadic relationship (e.g., gaze monitoring, intentionality, mental state attribution).

As stated above, ‘simple triadic attention’ describes a scenario where a subject and an agent are both attending to the same object. This triadic relationship may have been, though need not have been triggered by a shift of attention resulting from gaze following. When contrasted with ‘rich joint attention’, ‘simple triadic attention’ lacks mentalization skills; that is, the subject’s realization that the other agent has intentions, beliefs or desires about the object, and likewise lacks the capacity for the subject to attribute the mental state of ‘seeing’ to the other agent. Thus, ‘simple triadic attention’ describes only the triadic relationship itself, and not agents’ mental states. This stripped-down account of attention is built on previously described simple cognitive mechanisms that progress from eye detection to reflexive gaze following to a simple triadic attention scenario. It is similar to, if not synonymous with, what some authors (e.g., Butterworth & Jarrett, 1991; Corkum & Moore, 1998; Moore & Corkum, 1994) often refer to as ‘joint visual attention’ or ‘joint attention’ when describing an innate or learned ‘mechanism view’ of a potential attention mechanism. An oft quoted definition for simple triadic attention (usually called “joint visual attention”) is “looking where someone else is looking” (Butterworth, 1995, p. 29). It is also similar to the ‘ecological mechanism’ described by Butterworth and Jarrett (1991) consisting of simple visual processes that allow an infant to follow its mother’s gaze to an object. In describing these simpler cognitive mechanisms, these authors attempt to explain simple triadic attention behavior as relating to cognitive-developmental accounts of infant development that refrain from attributing complex and rich representational abilities to young infants. Their models produce similar behavioral outcomes without the need for mental state attribution or similarly complex mechanisms. ‘Simple triadic attention’ is also related to ‘simultaneous attention’ described by Tomasello (1995), where the attention of two individuals is fortuitously drawn toward the same stimulus – a behavioral outcome completely lacking any gaze following or mental state attribution mechanism as antecedent. Importantly, Emery and Itakura (Emery, 2000; Itakura, 2004) have both used the term ‘joint attention’ to describe a scenario identical to ‘simple triadic attention’. The authors use the term ‘shared attention’ to refer to a scenario where a subject and agent have attention focused both on the object and each other’s attention, with an apparent understanding of each other’s mental states and intentions; what most authors call ‘joint attention’, and what I have termed here ‘rich joint attention’. Incidentally, a mathematical Bayesian model (the ‘probabilistic model of shared attention’) has been created to induce what the authors term ‘shared attention’ behaviors in robots (e.g., gaze imitation, saliency determination) (Hoffman *et al.*, 2006). Assuming rich mentalization skills were absent in the case of the robot subjects, their use of the term ‘shared attention’ is more similar to ‘simple triadic attention’ than Emery and Itakura’s term ‘shared attention’.

The cognitively stripped-down concept of ‘simple triadic attention’ (hereafter termed ‘STA’) is not as widely cited in the literature as are concepts similar to ‘rich joint attention’ (hereafter termed ‘joint

attention’) when describing the presence of a triadic relationship between subject, agent and object. Joint attention has been defined as “a process whereby two individuals attend to the same object because one is checking, monitoring, or following the focus of attention of the other” (Williams *et al.*, 2005, p. 133). Proponents of this ‘rich’ model of joint attention contend that triadic relationships are often arrived at initially because of the subject’s ability to infer both intentionality and the mental state of seeing for the agent, coupled with the establishment of a link between the agent’s mental state and the object upon which they have focused their attention and presumably upon which they intend to act. This ‘rich’ model of joint attention, which Moore and Corkum (1994) refer to as the ‘commonsense view’ of joint attention, introduces three additional concepts that will be discussed in turn: active gaze monitoring, mental state attribution, and intentionality. Incorporating a third element (the object) in an attentional act is only possible with what Trevarthen (1979) called ‘secondary intersubjectivity’; a term denoting a level of mental state attribution absent from STA. Other authors (e.g., Carpenter *et al.*, 1998) have included acts of directing the attention of the agent to an object using intentionally communicative gestures (e.g., protodeclarative and referential pointing) as a fundamental component of joint attention, as part of what they describe as ‘ontologically later phenomena’. Given that most authors focused on animal studies discuss intentional communicative acts separately from joint attention (i.e., as ‘directing attention’ (Trevarthen & Hubley, 1978)), and have argued that joint attention itself is present before the emergence of intentional communicative acts (and issued cautions for conflating the two) (Butterworth, 1998), I will refrain from discussing these kinds of behaviors (i.e., pointing behaviors) until section 2.2.4. Although there is clearly no consensus as to what combination of underlying mechanisms are responsible for effecting a state of joint attention, a discussion of gaze monitoring, mental state attribution, and intentionality will help to focus our attention on the issues at hand.

2.2.3.1 Gaze Monitoring

Concerning active gaze monitoring, Tomasello (1995) posits that the bridge between STA and joint attention is the act of gaze monitoring. This has also been referred to as ‘gaze altering’ or ‘joint engagement’ (Carpenter *et al.*, 1998), ‘gaze alteration’ (Leavens & Hopkins, 1998), ‘referential glancing’ (Russell *et al.*, 1997), and ‘visual checking’ (Franco & Butterworth, 1996), and could be defined as follows: the act, by the subject, of looking from the object to the agent (in particular the agent’s eyes) and then back to the object. Experiments testing for joint attention behaviors in infants have used gaze monitoring behaviors as criteria for the presence of joint attention (e.g., Charman, 2003; Charman *et al.*, 2000; Reddy, 1998; Slaughter & McConnell, 2003; Striano *et al.*, 2006). Gaze monitoring is first seen in infants at ~8 months of age (Carpenter *et al.*, 1998), and is often interpreted as the period in which an infant is first able to attribute the mental state of ‘seeing’ to the agent (Bates, 1979). Gaze monitoring behaviors have been documented in apes (Call & Tomasello, 1998; Gomez, 1991; Leavens & Hopkins, 1998), monkeys (Emery, 2005; Scerif *et al.*, 2004), dogs (Call *et al.*, 2003; Miklósi *et al.*, 2000), and dolphins (Xitco *et al.*, 2001; Xitco *et al.*, 2004); these dolphin studies will be discussed in more detail in section 2.3. The act of actively monitoring the gaze of another in relation to an object is often cited as the behavioral ‘acid test’ exposing the presence of the other two

concepts underpinning joint attention; intentionality and mental state attribution. However, in contrast to the 'rich' view of joint attention, Moore and Corkum (1994) propose that gaze monitoring or checking behaviors might not indicate that the subject attributes mental states to the agent. Checking behavior might occur if 1) the subject's attention is drawn to a certain direction but finds nothing of interest there, causing the subject to turn attention back to the agent because of this violation of expectations, and 2) the subject (an infant in their example) has learned to expect a later behavior from the agent after first focusing on the object (e.g., a smile or a laugh). The subject may also have been fortuitously drawn back to the gaze of the agent because of a noise or other stimulus produced by the agent (Carpenter *et al.*, 1998). Furthermore, the subject may be attending to the object while simultaneously monitoring the behavior/attention of the agent through another modality, for example, audition; in this sense, 'rich' cognitive processes may be at work in the absence of gaze monitoring behaviors. As a behavioral manifestation, gaze monitoring may not be a direct indicator that the subject has attributed intentions or a mental state to the agent, though it is often cited as essential to joint attention.

2.2.3.2 *Mental State Attribution*

Mental state attribution is the ability of a subject to attribute a variety of conceivable mental states to an agent (e.g., seeing, believing, knowing). Importantly, these mental states could be ascribed to another agent based on the information derived from the actions of that agent, but also at times when the other agent is not acting, that is, when someone is simply looking at an object. Most authors distinguish types of mental states, placing simple mental states like 'seeing' on a lower cognitive level than, for example, 'believing'. It is at this lower level that Baron-Cohen's third function of the EDD (to interpret gaze as 'seeing') could be situated (Baron-Cohen, 1995). Mental state attribution is a fundamental component of the 'rich' view of joint attention, and there are other behavioral tests beyond gaze monitoring that may reveal the presence of this mechanism. A potentially revealing test is the subject's ability to follow gaze around a barrier. It has been proposed that if low-level processes govern gaze monitoring and gaze following behaviors as described above, then a subject would not be expected to search around a visible barrier obscuring the subject's view of the agent's line of sight toward an object that the subject can not see. If indeed 'rich' high-level processes allowing the subject to attribute the mental state of 'seeing' to the agent are at work, then the subject should follow the line of sight of the agent around the barrier. Chimpanzees, gorillas (*Gorilla gorilla*), bonobos (*Pan paniscus*) and orangutans have all been able to follow an agent's gaze around barriers (Brauer *et al.*, 2005; Povinelli & Eddy, 1996a; Tomasello *et al.*, 1999), as also have human infants (Butterworth & Jarrett, 1991; Moll & Tomasello, 2004); an ability that is often referred to as 'geometric gaze following' (Emery, 2005; Emery, 2000). Interestingly, this ability was also demonstrated in ravens (*Corvus corax*); an ability that took time to develop in young ravens (Bugnyar *et al.*, 2004). Some authors have argued that the barrier test is direct evidence that an animal is capable of attributing the mental state of 'seeing' to the agent (e.g., Hare *et al.*, 2001; Suddendorf & Whiten, 2001; Tomasello *et al.*, 2003). However, others have argued that barrier experiments may not yet be the definitive proof that the subjects were attributing mental states to the agent. A less rich interpretation of these data

suggest that the subject has simply learned to project a line of site for the agent, and learned how this line of site is affected by the presence of obstacles (Karin-D' Arcy & Povinelli, 2002; Povinelli *et al.*, 2000; Povinelli & Vonk, 2004). In another series of more advanced barrier tests, a dominant and a subordinate chimpanzee were given variable access to a food reward relative to a visual barrier (Hare *et al.*, 2000). The subordinate was more likely to choose the food reward that the dominant chimpanzee could not see, presumably to avoid food competition conflict. The authors concluded that the subordinate must have some level of understanding of the relationship between visual orientation and intentionality in the dominant chimpanzee, likely revealing something akin to mental state attribution for the concept of 'seeing'. These conclusions were challenged by experiments that did not replicate these findings (Karin-D' Arcy & Povinelli, 2002), leading these authors to conclude that the chimpanzees were not able to attribute the mental state of seeing to an agent.

One oft-used test of an animal's ability to attribute mental states to an agent through the use of gaze cues is the object-choice task. This test was developed by Povinelli *et al.* (1999) as a means of distinguishing between what the authors term 'low-level' vs. 'high-level' models of gaze comprehension (in a joint-attention scenario). High-level comprehension (equivalent to the 'rich' view of joint attention) suggests an ability to attribute 'unobservable', 'internal' mental states to other agents. The low-level model assumes that the animal can utilize the gaze cue to find the object (either as a learned association or as a simple communicative signal), but knows nothing about the mental states of the other agent. This experiment obliges an animal to choose between two or more baited containers with food hidden in only one container. The animal is exposed to a cue from the researcher; usually a gaze cue (e.g., head turned toward the correct container, eyes turned toward correct container, etc). If the animal is able to use these cues to locate the hidden food on the initial trials (i.e., before the animal could learn to use these 'meaningless' arbitrary cues as discriminatory stimuli), then it could be argued that the animal understands gaze as a cue for the state of 'seeing' in another agent. In general, negative results have been obtained on these types of tasks for monkey and ape experiments. For monkeys (Itakura & Anderson, 1996; Neiworth *et al.*, 2002), gaze cues alone were not sufficient for the animal to choose the correct reward; this was only possible when the gaze cue was used in combination with other cues (e.g., pointing). For apes, gaze-cue naïve animals rarely perform above chance on initial trials (see comments by Pack & Herman, 2004, p. 161), as will be discussed. Positive results have been obtained with studies of dogs. In one study (Hare *et al.*, 1998), two dogs were able to respond to initial object-choice trials using the human-gaze cue without error. In another experiment with dogs (Soproni *et al.*, 2001), a variety of gaze-cue types were used; head and eyes turned toward object, eyes-only turned toward object, and eyes turned in direction of object, but focused above the object (toward the ceiling). Dogs were able to use the first two cues to find the reward, but were reluctant to use the cue where the researchers' eyes were focused above the reward. This may mean that the dogs may have used the 'facing toward the reward' cues not as simple discriminatory stimuli, but rather may have understood the attentional/mental state of the researcher as revealed by the eye cues, although the authors conclude that simple high-level vs. low-level model proposed by Povinelli *et al.* (1999) does not properly take into account previous exposure to human

behavior for the test subjects, nor the possibility that domestication (i.e., selective breeding for animals sensitive to human communicative signals) in animals like dogs is a potential reason for their comprehension. They understand these positive results for dogs to be evidence that dogs understand the communicative nature of the human gaze cue, but not necessarily their ability to attribute mental states.

In a test of the ability of six dolphins to spontaneously understand gaze cues on initial object-choice trials, Tschudin *et al.* (2001) found that five of the six dolphins were able to perform well above chance for these initial trials. The dolphins were able to use researchers' eye-gaze (i.e., a turned head and eyes facing the correct object while the torso faces forward) to choose the correct object, without any accompanying gestures (e.g., pointing). Like Soproni *et al.* (2001), these authors concluded that dolphins were able to comprehend the communicative nature of the human-gaze signal, though they do not discuss whether or not this is concomitant with mental state attribution. A recent test of a dolphin's ability to use gaze cues in an object-choice task was performed by Pack and Herman (2004). For these tests, two dolphins that had never been exposed to human gaze signals during their training were tested for spontaneous comprehension of these cues on initial trials. Although these dolphins had been used in earlier studies of their ability to understand pointing gestures (see section 2.2.4.6), researchers had used opaque goggles to obscure their eyes, and had remained in the face-forward position during these trials in an attempt to avoid exposing the dolphins to gaze cues. For these tests, the dolphins were given instructions in a symbolic gestural system in which they had been trained, but the trainers substituted a gaze-cue toward the object instead of a sign for the object. For these initial trials, the researcher turned his/her head and looked at the correct object. Both dolphins were nearly error free on these trials, leading the authors to conclude that dolphins are able to 'interpret human gaze spontaneously' (Pack & Herman, 2004, p. 167). The dolphins were also tested for their comprehension of static gaze – a gaze cue presented to the dolphin by lowering an opaque board to reveal the experimenter already in the gaze position. For these trials, the dolphins performed equally as well as the dynamic head-turn trials. Although the dolphins in these tests were able to use gaze-cues on early trials, they cautiously conclude that this reveals a 'low-level' model of gaze comprehension; one where the gaze cue can simply be used as a communicative cue to indicate a particular object (or direction where the object is to be found), but not necessarily indicating that the dolphin attributed the mental state of 'seeing' or 'perceiving' to the researcher (other agent) – a high-level model.

Despite the cautious conclusions of 'low-level gaze comprehension' for the positive evidence seen in object-choice experiments with dogs and dolphins, a research team studying Rhesus monkeys (*Macaca mulatta*) has argued that their results reveal that this species is able to attribute the mental state of 'seeing' to other agents (Flombaum & Santos, 2005). In a series of object-choice experiments meant to mimic 'naturalistic' food competition scenarios for Rhesus monkeys, the study subjects could take a food reward from two 'competitor' researchers who were positioned in a series of 'perceptual' states, including head and eyes facing toward and away from the food reward, eyes

averted toward or away from the food reward, and holding up visual barriers that occluded the eyes. In all experimental situations, the monkeys took food from the researchers who had their attention or eyes either averted or hidden from the food reward, what the authors described as encoding “information about what a competitor can or cannot see” (Flombaum & Santos, 2005, p. 449). They did, however, concede that, for some of their experimental situations, a simpler rule might have been at work leading to this behavior; one that dictates that the subject merely avoids the competitor who is looking forward, thus avoiding the need for mental state attribution. Although an even simpler rule like ‘avoid approaching any agent whose forward facing eyes you detect’ would likely have covered all experimental situations. Hirata and Matsuzawa (2001) reported a food competition experiment where one chimpanzee (the witness) watched as a human researcher placed food under a container. A second chimpanzee (the witness-of-witness) could see the first chimpanzee, but not the researcher’s actions. The authors reported that the witness chimpanzee would behave so as to mislead the witness-of-witness chimpanzee by leading them to the wrong container, and the witness-of-witness chimpanzee would engage in tactics to forestall the witness from accessing the food (presumably to increase their chances of gaining access to the food). This was interpreted as a form of deception wherein both chimpanzees had knowledge of the mental states of both ‘seeing’ and ‘knowing’.

Other observational work with animals has produced results that may be evidence of a mental state attribution in animals. Female hamadryas baboons have been observed grooming subordinate males behind a barrier that obscures them from the view of the dominant males (Whiten & Byrne, 1988). Although this may be evidence that the female baboon has attributed the mental state of ‘seeing’ to the dominant male, and thus engaged in deceptive behavior, it is also plausible that these behaviors are the result of more basic learning mechanisms (e.g., differential reinforcement), and that the female baboon has not attributed any mental state to the other baboons (Emery, 2005). Food-caching behaviors in birds may also be evidence that animals are able to attribute the mental state of ‘seeing’ to conspecifics (Emery, 2005). In an attempt to protect food caches from other birds, many corvid species will cache food behind barriers (Bugnyar & Kotrschal, 2002), delay caching until other birds have left the area, or they make false caches (Emery *et al.*, 2004; Heinrich & Pepper, 1998; Vander Waal, 1990). Bee-eaters (*Merops orientalis*) have also been shown to avoid entering their nests when a potential predator is visually monitoring the nest (Watve *et al.*, 2002). Unfortunately, these observations suffer from similar problems of interpretation; one can easily postulate a learning mechanism, or an evolutionarily selected for behavior that results in both caching and nest avoidance without the need to ascribe mental state attribution abilities to corvids or bee-eaters.

The question as to whether or not mental state attribution can ever be inferred from experiments with animals is currently hotly debated in the literature. However, animal experiments may provide more insight into the problem than studies with human infants. A stumbling block for comparative psychologists referring to human infants studies is the fact that mental state attribution is a skill that is clearly utilized by adult humans, so the question for infants is ‘when’ this skill develops, and not ‘if’ it develops. Subsequently, authors who ascribe a mental state attribution mechanism to a young infant

will be criticized only for unwisely pushing the envelope of psychological development in infants, and not committing the sin of positing an unattainable cognitive mechanism for a subject, as may be the case for non-human animals. This is perhaps why studies focusing on mental state attribution in animals are likely to be more valuable in honing experimenters' skills in producing results that lead to conclusive proof that mental state attribution occurs for species where it is still thought possible that they never develop such skills. Of all species, the great apes, and especially chimpanzees, have been at the center of the debate as to whether or not experiments involving gaze monitoring and barrier tests are capable of eliciting behaviors that could be interpreted as requiring mental state attribution. These and other experimental paradigms have been central to this discussion, and central to the discussion of how these cognitive concepts contribute to joint attention.

Perhaps the mental state attribution debate can be best characterized by the competing arguments offered by primatologists at two research institutions; Michael Tomasello at the Max Planck Institute for Evolutionary Anthropology in Leipzig, Germany, and Daniel Povinelli of the University of Louisiana in the USA. This debate has evolved into what the authors themselves describe as a 'gentle controversy' (Povinelli & Vonk, 2004; Povinelli & Vonk, 2006). The origins of the current debate stem from claims made by the Leipzig group that chimpanzees must understand at least something about the psychological states of others (Tomasello & Call 2006; Tomasello *et al.*, 2003). Whereas the Leipzig group initially concluded that chimpanzees knew nothing about the psychological states (mental content) of other agents (Tomasello & Call 1997), they revised their position based on subsequent experiments (e.g., Call, 2001) that they interpret as providing evidence of mental state attribution (see Tomasello *et al.*, 2003). The Louisiana group, however, are highly skeptical of these claims, and assert that current experimental paradigms are incapable of providing enough evidence to lead to the conclusions offered by the Leipzig group (Povinelli & Vonk, 2004).

The Leipzig's group is of the opinion that granting chimpanzees the ability to 'understand seeing', and therefore attribute the mental state of seeing to another agent, is the most parsimonious explanation of their experimental results (Tomasello & Call 2006). They argue that this cognitive ability could explain results of previously described experiments involving chimpanzee gaze following (Tomasello *et al.*, 1998; Tomasello *et al.*, 1999), and the dominant/subordinate food competition experiment (Hare *et al.*, 2000; Hare *et al.*, 2001). A third 'follow-up' experiment was designed by the Leipzig group following an experiment by Povinelli and Eddy (1996b) that found that chimpanzees will gesture for food somewhat indiscriminately to either of two researchers in a variety of states of attention including blindfolded, bucket on head, hands over eyes, eyes closed, looking away, back turned and looking over shoulder. Povinelli and Eddy (1996b) proposed that the chimpanzees had a general notion of perceptual access based on body orientation, but that the eyes and face played no role in indicating attention, and it follows that they then did not attribute the notion of 'seeing' to the agent. For the Leipzig group's follow-up experiment (Kaminski *et al.*, 2004), a similar experimental situation was created, but using only one researcher in various states of attention; an attempt at creating a more 'naturalistic' situation. They found that the subject did indeed respond differently with

its begging gesture to the various attention states of the researcher, indicating sensitivity to facial orientation as well as body orientation. Again, for this experiment, ascribing the ability to attribute the mental state of 'seeing' to the agent was offered as the best explanation for the chimpanzees' performance. The Leipzig group have offered a list of experimental findings where the mentalistic explanation that 'chimpanzees understand seeing' is superior to the strictly behavioral explanations offered by the Louisiana group (see Tomasello & Call 2006, p. 381).

In stark contrast to these conclusions, the Louisiana group is of the opinion that it is certainly possible for chimpanzees to attribute mental states to other agents, but that "the research paradigms that have been heralded as providing evidence that they do reason about such mental states, do not, in principle, have the ability to provide evidence that uniquely supports that hypothesis" (Povinelli & Vonk, 2006, pp. 386-387). They argue that the standard approach to designing experiments meant to elicit responses that are based on mental state attribution and not simply the subject responding to behavior, is logically flawed, and relies on the experimenter's implicit knowledge of folk psychology to differentiate between these two response types. The Louisiana group has criticized experimental designs like this as often resorting to 'argument by analogy' when interpreting results; that is, the fact that great apes are closely related to humans, a species known to have the ability to attribute mental states, means that they likely have this ability as well (Emery, 2005; Povinelli & Giambrone, 1999; Povinelli & O'Neill, 2000). In summarizing the Povinelli and Eddy (1996b) experiment, they argue that all of the chimpanzees' responses can be understood as having derived from a system of reasoning about behavioral states that does not require reasoning about mental states. Their argument states that the design of the experiment itself is incapable of differentiating between responses based on reasoning about behavior and reasoning about mental content, an argument that also applies to the experiments of the Leipzig group. The Louisiana group rejects all current and previous experimental designs and results as providing compelling evidence that mental state attribution is present in the chimpanzee mind. They stress however that this is a design flaw in the experiments themselves, and offer a variety of new experimental designs that may yet reveal the presence of mental state attribution (Povinelli & Vonk, 2006). The Louisiana group offers an alternative hypothesis capable of explaining the results of experiments involving mental state attribution. Termed the 'reinterpretation hypothesis', they posit that the ancestors of humans and chimpanzees possessed a suite of systems dedicated to representing and reasoning about behavior (Povinelli & Barth, 2005). This system was, however, incapable of reasoning about mental states or intentions. They posit that, at some point in the evolution of modern humans, and perhaps coincident with language evolution, human ancestors evolved an additional cognitive mechanisms that allowed them to reason about their own and others' mental states, and that this was grafted onto the existing representational system. Thus, it is typical for animals (including humans) to represent behaviors, but that humans are then capable of understanding these behaviors in terms of mental states. This then goes a long way in explaining why chimpanzees seem skilled at tasks requiring representing behaviors (e.g., gaze following, gaze monitoring), without needing to ascribe them mental state attribution abilities (Povinelli & Barth, 2005; Povinelli & Vonk, 2006).

The results of great ape mental state attribution experiments are, unfortunately, equivocal. Thus, the role that mental state attribution may play in a joint attention scenario is clearly related to the nature of the hypothesis offered by the researcher, the definition of joint attention being used, and the interpretation of experimental results. Nonetheless, the majority of joint attention paradigms and definitions consider that the subject must attribute the mental state of ‘seeing’ to the agent in order for the ‘rich’ or ‘common’ view of joint attention to differentiate itself from STA (e.g., Baron-Cohen, 1995; Tomasello, 1995; Williams *et al.*, 2005).

2.2.3.3 Intentionality

An additional cognitive process central to joint attention, and often described in relation to mental state attribution, is intentionality. For Baron-Cohen’s (1995) model, the EDD (including the ability to attribute the state of seeing to an agent) is only half of the most basic level of underlying processes leading toward joint attention and eventually to full-blown ‘mindreading’ (Theory of Mind). Together with the EDD, he suggests the presence of an ‘intentionality detector’ (ID); a simple perceptual mechanism that attributes desires and goals to any object that moves of its own accord (Langton *et al.*, 2000). When coupled with the EDD, the ID allows the subject to attribute goals and desires to an agent whose attention is focused in the direction of an object. This relationship is *ipso facto* sufficient to conclude that the subject also attributes the mental state of ‘seeing’ to the agent; thus, these mechanisms, while theoretically separate, work in tandem. The ID appears related to the philosophical idea of the ‘intentional stance’, described by Dennett (1987). In an attempt to categorize the types of mental content that allow individuals to understand the behavior of other social agents in the world, Dennett provides three levels of possible predictive stances: the physical stance, the design stance and the intentional stance. The intentional stance is the most complex/abstract of the three, but allows the individual the greatest flexibility and thus predictive power. Dennett’s use of the term ‘intentionality’ is not limited to ‘simple intentions’, but includes a large set of mental content including beliefs, desires, thoughts, hopes, etc. (Baron-Cohen, 1995); something more akin to full blown Theory of Mind (see section 2.2.3.4) than ID. For Baron-Cohen’s ID module, intentions refer to the much more basic goals and desires of a potential agent (e.g., *wants* to escape, *wants* to get the cheese). These intentions are derived from the perception of behavioral stimuli emulating from a self-propelled object (agent), and need not be limited to information from the visual stimuli, that is, tactile perception of an agent brushing up against your leg, or the auditory stimuli of an alarm-call. Furthermore, unlike the ID, Dennett’s intentional stance first must assume that the agent is a rational being. It then allows the subject to predict what desires that agent ought to have, followed by further predictions as to how the agent will behave in order to further its goals and desires. For the ID, intentionality is attributed to the agent without the need for the attribution of rationality to the agent, allowing it to exist at a more fundamental cognitive level. This ID module then assumes the agent is an ‘intentional agent’ (see Carpenter *et al.*, 1998, p. 4), though not necessarily a rational one. The ID is similar to the Theory of Mind Mechanism, System 1 (TOMM₁) as described by Leslie (1994). The job of this module, like the ID, is to interpret the actions of other agents as goal-directed actions,

although, unlike the ID, this mechanism limits itself to those entities defined as (living) agents, whereas the ID is sensitive to any self-propelled object. For Baron-Cohen, the interaction of the EDD and the ID in a triadic relationship leads to what he terms the ‘shared attention mechanism’ (SAM) – a ‘meeting of the minds’ that is, for all intents and purposes, analogous to the ‘rich’ view of joint attention. As a mechanism, SAM is theorized to be a means of bridging the gap between the EDD and the ID – a supplemental module that combines the information from the two lower modules; integral to this process is the ability of the EDD to attribute mental states to the agent; an ability beyond the scope of the ID alone. As a final note, for this review, ‘intentionality’ will refer to the simple version of intentions described by Baron-Cohen, and not the rich version described by Dennett. It is important to note that the ID ascribes goals/desires to another agent based exclusively on observable behavior – attributing goals only to the behavior itself, not to the unobservable mental states of the agent.

Premack (1990) has suggested that the perception of ‘intention’ is a ‘hard-wired’ trait that classifies all self-propelled objects as acting ‘intentionally’. Premack describes studies with infants showing their responses to sequences of object interaction whereby they appear to attribute self-propelled objects as having ‘goals’; a first-order state of intentionality that is similar to an ‘intentionality detector’. Tomasello has also described something akin to an ‘intentionality detector’ developing early in an infant’s life: ~10 months (Carpenter *et al.*, 1998; Malle *et al.*, 2001; Tomasello & Haberl, 2003; Tomasello *et al.*, 1993). Tests of young children suffering from autistic spectral disorders have found evidence that they are, despite certain deficits, able to perform adequately in experiments designed to test their understanding of the intentions of other agents (Carpenter *et al.*, 2001). None the less, similar studies have revealed that these children have difficulty with more complicated goal-oriented joint attention tasks, and are known to have major deficits in tasks requiring complex Theory of Mind comprehension (see review by Baron-Cohen, 2000). Carpenter *et al.*’s conclusion here is that an ‘intentionality detector’ may be an early and/or low-level process (like Baron-Cohen’s ID) that is important to joint attention, but that other mechanisms must also be involved, as intentionality detection is not enough to produce joint attention behaviors for autistic children. Wellman and Woolley (1990), have also described something akin to an ‘intentionality detector’ which they termed a ‘simple desire psychology’ – allowing young children the ability to attribute desires (intentions) to agents at an early age, before developing more advanced mentalistic abilities like belief attribution. Meltzoff (1995) describes an experimental test for a low-level ‘intentionality detector’ in pre-verbal infants younger than two and a half years, which he calls the ‘behavioral reenactment procedure’. The test consists of an agent (an adult) attempting and failing to perform an act, and later testing the infant to see if they themselves would complete the action that (to an adult observer) it appeared that the agent was trying to complete. Eighteen-month-old children were able to pass this test, leading the authors to conclude that they understood something about the intentions of the agent. In a subsequent experiment, children were able to differentiate between a human hand and other objects traveling the same path in space toward a target. The children were able to complete the act themselves after watching the human hand, but not the objects, again perhaps indicating their ability to map intentions onto the agent. A test on even younger infants (10-11 months) describes infants’ showing more

interest in a video paused before an agent completed an ‘intended’ action (e.g., picking up a towel), than a video paused after the action was completed, leading the authors to conclude that infants of this age are sensitive to the intentions of other agents (Baldwin & Baird, 2001).

It has been posited that an ‘intentionality detector’ is likely present in autistic children and the great apes, but that an additional mechanism (i.e., ‘shared intentionality’) dedicated to motivating the individual to share emotions and experiences with others is the ‘missing link’ leading to full blown joint attention, Theory of Mind, and mind reading (Tomasello *et al.*, 2005). Following these observations, the authors have subdivided joint attention into two stages of development; ‘joint perception’, which is present at ~9 months, and ‘coordinated joint engagement’, involving the proposed ‘shared intentionality’ mechanisms, which begins to develop between 12 and 15 months. The later stage involves the uniquely human collaborative ‘shared intentionality’ mechanism, whereas the early stage relies simply on a basic intentionality detector. For the author’s description of ‘joint perception’, both subject and agent may be aware of each other’s goals (and perceptions) as related to the object, and so this resembles the concept of ‘rich’ joint attention. However, ‘coordinated joint engagement’ is a uniquely human trait, requiring the subject and agent to share the same goal, and to work together toward that goal. This demarcation has, however, been criticized. Kuczaj and Highfill (2005) pointed out that something akin to ‘coordinated joint engagement’ and ‘shared intentionality’ are the only possible mechanisms behind some of their observations of coordinated play in dolphins, with additional evidence for similar explanations of chimpanzee behavior (Kuhlmeier & Birch, 2005). In any event, it is clear that in human infants, a mechanism is in place by the age of three that allows the child to fully understand even the most complex intentions of other agents (see discussion by Meltzoff, 1995).

It is important to note that ‘intentionality’ and ‘mental state attribution’ are not analogous. Attributing an agent intentions or desires does not necessarily require the subject to attribute mental states such as ‘seeing’ or ‘believing’ to the agent as well; these may be discrete mental phenomena. The intentionality mechanism described here may be an elementary mechanism that attributes only a basic ‘desire’ to act on an object to the agent, and may perhaps be ascertained through the reading of behavioral cues without the need for mentalization (Povinelli & Barth, 2005). Coupled with other mechanisms (like eye-detection and gaze following), this simple system may be enough to govern joint attention situations without complex mental state attribution (e.g., believing or knowing).

In an attempt to uncover something akin to the modern form of a simple ‘intentionality detector’ in chimpanzees, researchers have performed a variety of experimental tests. Perhaps the first ever test of a chimpanzee’s ability to infer desires and intentions for an agent was conducted by Premack and Woodruff (1978). A chimpanzee (Sarah) was presented with videotaped scenarios of a human attempting to solve a variety of problems. She was then presented with a pair of photographs with possible solutions to the problem, and was able to correctly choose the appropriate solution in most cases. This led the authors to conclude that Sarah was able to discern the goal of the agent’s actions

and therefore infer their intentions. In subsequent research however, the conclusions drawn here were disputed (Savage-Rumbaugh *et al.*, 1978), and future attempts to design new experiments that could prove Sarah was able to infer an agent's intentions were unsuccessful (Premack, 1986). Later experiments (Povinelli *et al.*, 1998) presented chimpanzees with two scenarios; one where an agent attempted to perform an action leading to a desired goal (e.g., bringing the subject some juice) in good faith, but was hampered by clumsiness or other outside influences, and one where the agent intentionally spoiled the attempt (e.g., spilled the juice) with (what humans deemed) obvious intention. The chimpanzees in this experiment were unable to differentiate between the two types of action. In similar tests, individual chimpanzees were unable to determine which food-reward bucket had been marked accidentally or intentionally by a human researcher, although a language-trained orangutan was successful at this task (Call & Tomasello, 1998).

The only recent experimental evidence suggesting the presence of an intentionality detection mechanism in chimpanzees is that of Call *et al.* (2004). The experiments described here presented chimpanzees with two scenarios, similar to the Povinelli *et al.* (1998) experiment, but without explicit training. A researcher passed food to a chimpanzee through a Plexiglas wall, but was delayed in doing so either because the researcher was unable (i.e. making a good faith attempt but delivering the food clumsily), or unwilling (i.e., by simply refusing to give the food to the chimpanzee). These conditions were varied across two experiments. The results showed that the chimpanzees produced more begging and assertive acts (e.g., banging on the glass or poking fingers through the feeding hole) in conditions where the researchers were unwilling to give them food. The authors suggest that this might indeed show that chimpanzees are sensitive to the intentions of the agents for these tests, although they concede that more basic learning from exposure to the behaviors and results of the researcher's actions might have been responsible for the results. They further discuss a distinction between a behavioral/mental goal, and an actor's intentional goal. That is, a chimpanzee might be able to discern from the types of behaviors being observed that the goal of those behaviors is to pass the food to them (behavioral/mental goal), but that this might not mean the chimpanzee has attributed a mental state to the actor/agent equivalent to an intention to pass the food to them (intentional goal). Subtle differences in the types of behaviors being witnessed might differentiate one from the other.

Summarizing their position on the implications of these results, Tomasello *et al.* (2003) hypothesize that chimpanzees are able to understand something about the intentional structure of behavior (i.e., 'intention in action', (Searle, 1983)), and how perception influences it (i.e., they can read goals from an agent's behavior and relate this to the agent's attention state). However, they hypothesize that chimpanzees do not understand 'prior intentions' (i.e., indirectly observable intentions) (Searle, 1983) or 'communicative intentions' (i.e., intentions towards others' psychological states (Searle, 1983)). Some experimental scientists (e.g., Scerif *et al.*, 2004) have offered similar explanations as to why Diana monkeys (*Cercopithecus diana diana*) appear to engage in joint attention (including gaze monitoring) behaviors. These authors suggest that Diana monkeys may not attribute mental state or intentions to the agent, but may none the less be involved in a triadic relationship that is more than

simply STA; perhaps a relationship where understanding ‘intention in action’ is the mitigating factor. Identical explanations have been provided by authors working with gibbons (Horton & Caldwell, 2006). The difficulty of experimentally determining the difference between ‘goal direction actions’ and the ‘mental state of intention’ (see Emery, 2005) for animals (primarily chimpanzees) has been discussed previously by Menzel (1974) and Dickenson and Balleine (2000).

Recently, others have explored this potentially valuable ‘middle ground’ proposal that intentions can be derived from behavioral cues alone, without need for attribution of intentions to the agent itself; only to the action (similar to Searle’s ‘intention in action’). As summarized by Baldwin and Baird (2001), the direct observation of the flow of motion provides clues at the structural level that lead toward perception of ‘statistical regularities’ allowing the subject to detect the intention of the action itself. Thus, intentionality may be derived from low-level action patterns detectors looking for ‘structure’, and not mental state attribution, although some authors have pointed out that structure alone will not allow a subject to detect intention all of the time (e.g., Searle, 1984). This model will, of course, only be relevant to actions that are isomorphic with intentions, thus not addressing hidden intentions, or intentions that have no immediate or linearly structured behaviors – these intentions are seen to be functions on a separate level. Thus, similar to Searle’s hierarchy of intentions described earlier, Baldwin and Baird (2001) describe a ‘generative knowledge system’ that can come to understand the various levels of intention. For humans, they give examples of levels of intention as small actions (e.g., grasping a dish), higher level tasks (e.g., washing a dish), global intentions (e.g., clean the kitchen), daily goals, etc. (Baldwin & Baird, 2001, p. 176). Presumably, for young infants and possibly animals, an ‘intentionality detector’ mechanism would only be sensitive to the lowest level of intention. This may also be related to Tomasello *et al.*’s (2005) discussion of a distinction between ‘intentions’ and ‘goals’; intentions being a ‘plan of action’ that is executed in pursuit of a goal. Perhaps a low-level intentionality detection mechanism can detect the presence of an intentional (goal oriented) act, without needing to assume direct knowledge of the agent’s goal.

Butterworth and Jerrett (1991) have offered a model of joint attention that incorporates important aspects of intentionality. This ‘ecological mechanisms’ model is understood to be part of an earlier form of joint attention (distinguishable from STA due to the presence of ‘intention’) and functions as follows; the agent first looks at an object, followed by the subject co-orienting so that there is a triadic relationship (subject-object-agent). In this scenario, both the subject and the agent understand the act of changing focus of attention to an object as an intentional act, and that the object is the focus of that intentional act for both subject and agent, thus creating a ‘meeting of the mind’ (Butterworth, 1998). This ‘intentional act’ is likely the same as Searle’s ‘intention in action’ (Searle, 1983), the lowest level of intentionality. Thus, in contrast to the ‘rich’ view of joint attention, the ‘ecological’ joint attention scenario proposed here only requires intentionality, not mental state attribution or gaze monitoring. Butterworth (1998) goes on to describe various stages of joint attention (e.g., ‘geometric joint attention’) that are relatable to stages of development in the infant that coincide with later stages of joint attention offered by Carpenter *et al.* (1998). For Carpenter *et al.* (1998), joint attention behaviors

for humans emerge at around one year – the period when an infant is first able to regard both itself and the others as ‘intentional agents’, perhaps revealed by ‘checking’ or ‘gaze monitoring’ behaviors, as has been previously argued. Moore (1998) has strongly criticized the suggestion that these and related behaviors are a sign that the infant understands others as ‘intentional agents’, describing the evidence supporting the above model as ‘unconvincing’ and ‘circumstantial’. Moore (1998) offers a cognitive sensorimotor account to explain joint attention like behavior, comprised essentially of those elements that have previously been described as leading to STA. In summary, all of the models offered up to this point fail to offer a consensus as to what intentionality is, whether animals can attribute intentionality to other agents, or if intentionality is necessary for effecting a joint attention scenario. Although there does (generally) seem to be some agreement that both intentionality and mental state attribution are in some way necessary to differentiate STR from joint attention.

2.2.3.4 Theory of Mind

A note should be made here concerning Theory of Mind. Theory of Mind has been defined as ‘the ability to infer the psychological states; intentions, beliefs, desires, etc. of other individuals from non-verbal cues’ (Emery, 2000). I have discussed how joint attention is related to the ability to attribute simple mental states (e.g., ‘seeing’), and intentions to an agent. For many authors, these abilities, if posited for the notion of ‘joint attention’, are placed on a continuum that eventually leads to Theory of Mind, for example Baron-Cohen’s model that combines the ID and EDD to form the SAM and eventually the ToMM (Theory of Mind Mechanism) (Baron-Cohen, 1995). Many consider the attribution of ‘beliefs’ as the missing ingredient leading to a full-blown Theory of Mind. These kinds of ‘advanced’ mental states have been described as ‘epistemic mental states’ (e.g., believe, know, guess, imagine, pretend); and only appear to arise when and if an additional mechanism (e.g. the ToMM) appears (Baron-Cohen, 1995; Leslie, 1994). It is proposed by some that the Theory of Mind appears late in the development of human children (between 36 and 48 months)(Britton *et al.*, 2002), and is likely never seen in non-human animals.

Unfortunately, when reviewing the literature, it can often be difficult to distinguish how the skills comprising a ‘rich’ interpretation of joint attention are in any way unlike those comprising a Theory of Mind; for example, the idea of ‘belief’ can be easily conflated with ‘desires’ and ‘intentions’, especially given that the originators of the term ‘theory of mind’ proposed testing for this ability using an experimental design looking for a chimpanzee’s ability to infer the ‘intentions’ of another agent (Premack & Woodruff 1978). Some accounts also seem to confuse the idea that a subject that may attribute ‘intentions’ to an agent, must then regard the agent as ‘an intentional being like me’ (Carpenter *et al.*, 1998, p. 5); a mentalistic function (unnecessarily) similar to Theory of Mind. But, importantly, many modern authors have emphasized a distinction here between joint attention and Theory of Mind (Tomasello *et al.*, 2003). In addition to ‘beliefs’, the idea of ‘knowledge’ either one’s own or another’s knowledge, is integral to the idea of Theory of Mind (Cheney & Seyfarth, 1990; Emery, 2005; Suddendorf & Whiten, 2001). This has led to tests like the ‘false belief task’ (a test as to whether or not a subject understands that another individual can hold different beliefs from

themselves) becoming central to determining the presence of Theory of Mind in animals (Emery, 2005). Although ‘false belief’ has been tested in dolphins (Tschudin, 2006), resulting in extremely equivocal results, these experiments were not directly relatable to either joint attention or echoic eavesdropping. Neither is a discussion of ‘secondary representation’ (the ability to represent other minds separate from understanding others intentions) described by Perner (1991), nor the ‘representational model of mind’ or ‘mentalism’ discussed by Meltzoff (1995) relatable to joint attention and echoic eavesdropping. And while other cognitive abilities like self awareness and ‘simulation’ Theory of Mind (see Emery, 2005), and the experimental results of mirror-self recognition tests in animals (Gallup, 1970; e.g., Plotnik *et al.*, 2006; Povinelli *et al.*, 1997a; Reiss & Marino, 2001) are interesting, they are only peripherally related to joint attention, and so will not be discussed here.

That animals possess a full-blown Theory of Mind has been rejected by many of even the most lenient of interpretations offered by experimental scientists (e.g., Emery, 2005; Premack, 1988; Tomasello *et al.*, 2003), and so it is beyond the scope and purpose of this review to attempt an account of the research paradigms and theoretical models that have been applied to Theory of Mind in animals. The demonstrated ability of a dolphin to engage in echoic eavesdropping behaviors has led researchers to emphasize the relationship between this ability and dolphins’ comprehension of referential pointing (as will be discussed in section 2.2.4), but that this immediately leads to the notion that dolphins have a Theory of Mind has been rejected (Herman *et al.*, 1999). Joint attention has been called the ‘crossroads’ where infants meet the world of ‘collective cognition’ (Carpenter *et al.*, 1998); presumably a crossroads that, if followed, will continue toward full-blown Theory of Mind. Given this affirmation of what would appear to be a natural boundary, the focus here will remain on joint attention, and not the cognitive abilities that reach beyond it.

That being said, perhaps the most useful paradigm offered so far that can ascribe a hierarchical relationship to the cognitive processes underpinning joint attention is that offered by Premack (1988), and summarized by Emery (2005). This paradigm lists three ‘classes’ of Theory of Mind; ‘perceptual’ (understanding seeing and attention), ‘motivational’ (understanding desires, goals and intentions) and ‘informational’ (understanding knowledge and beliefs)’ (from Emery, 2005). Premack’s hierarchy covers the various stages of cognitive development that have been outlined so far, but reframes them in a discussion of Theory of Mind, though it is evident that, according to his hierarchy, true ‘full-blown Theory of Mind’ is only encountered in the final (informational) tier/class. The ‘informational’ class encompasses the notion of ‘beliefs and knowledge’ (described above); mechanisms that are not relevant to a discussion of joint attention. All of the elements that comprise joint attention can be found in the lower two classes; ‘motivational’ and ‘perceptual’. The ‘perceptual’ abilities (contained in Premack’s first class of Theory of Mind) are those designed for eye-detection, gaze following, and reflexive gaze shifts that allow an organism a special kind of sensitivity to the attentional states of other organisms and that may result in STA. The ‘motivational’ abilities (contained in Premack’s second class of Theory of Mind) are what lead directly to joint attention; gaze monitoring, gaze

alteration, mental state attribution and intentionality. Although these cognitive abilities are likely best understood as discrete yet related abilities that are not necessarily placed on a continuum, Premack's hierarchy encapsulates the relevant components of joint attention, providing an appropriate summary to the topics discussed so far.

2.2.3.5 Joint attention in animals

Apart from the debate (highlighted above) concerning what unobservable cognitive processes must be in place for joint attention to be achieved, there is further debate as to what combination of observable behaviors exhibited by a subject should be classified as joint attention (see discussions by Butterworth, 1998; Carpenter *et al.*, 1998). Whereas some claim that joint attention is present for triadic relationships involving infants starting as early as 6 months (Butterworth & Jarrett, 1991), others consider joint attention attained only between 12 and 15 months (Carpenter *et al.*, 1998). Aside from the differences about what cognitive mechanism might be at play, this discrepancy is due in large part to differing methodologies that account for joint attention by hunting for disparate behavior; (e.g., simple gaze shifts vs. attention getting behaviors). Studies on human infants have not reached a consensus in method, and so it should come as no surprise that many authors have observed 'joint attention' in a variety of animal species, without any agreement as to what behaviors or underlying mechanisms deserve this label. For example, Pepperberg and McLaughlin's (1996) article describes joint attention behaviors in language trained parrots (*Psittacus erithacus*). The authors describe a joint attention scenario involving STA between the researcher and the parrot focused on an object, as well as the presence of referential pointing behaviors, which they term 'cued following' and 'joint focus'. They point out that this joint attention scenario does not require an understanding of intentions on the part of the subject. In training the parrot to acquire new labels for objects, these joint attention scenarios were contrasted with training scenarios not involving the researchers' shared focus with the bird. The results of the study suggest that the parrots were better able to learn object labels during joint attention training scenarios. Joint attention for these authors then includes gaze following, triadic relationships and referential pointing, but not mental state attribution or intentionality; a combination of behaviors and underlying causes that are quite different to the 'rich' view of joint attention described previously, and more closely resembling a combination of STA and 'imperative pointing' (see section 2.2.4.4).

An even richer combination of behaviors considered critical to the existence of joint attention in animals has been offered by Kumashiro *et al.* (2003). In their study of behavior imitation in Japanese monkeys (*Macaca fuscata*), the authors initially define joint attention as "an observer following the gaze of a performer to a target" (Kumashiro *et al.*, 2003, p. 82), but then go on to include pointing gestures, intention, and to some extent intentional communicative acts as fundamental to joint attention behaviors. Thus, joint attention for these experiments includes a far wider subset of behaviors and cognitive processes than even the putative 'rich' definition of joint attention. Russel (1998), in her study of chimpanzee gaze following, has also described joint attention as a triadic relationship stemming from gaze following (equivalent to STA), but goes on to describe this as an

intentional communicative act. For Emery *et al.*'s (1997) study of gaze following and joint attention in Rhesus monkeys, joint attention was defined as the subject following gaze to the object which is the focus of the agent's attention. The monkeys in this study were able to reliably follow the gaze cues of conspecifics to a target resulting in what they term joint attention. The authors do not discuss any mentalistic account for this scenario, nor make mention of referential pointing, thus this definition of joint attention here is equivalent to STA.

In contrast, Povinelli and Eddy (1996a) describe an experiment where chimpanzees were able to follow the gaze of a conspecific around a barrier, pointing out that this experiment does not count as joint attention because it could not prove that the subject could attribute mental states or intentions to the agent, a feature that they had argued in the past as being essential to joint attention (see Povinelli & Eddy, 1994). In a telling example of how the term joint attention is often haphazardly conflated with any number of related behaviors, Brauer *et al.*'s (2005) article describing gaze following behaviors in great apes listed 'joint attention' as a keyword for the article, but never once mentioned joint attention in the article itself; the discussion is limited to gaze following and gaze monitoring behaviors. On a final note, for studies on humans, joint attention behaviors are sometimes considered to include abilities and processes far outside the 'rich' view of joint attention, and clearly beyond the cognitive skill set utilized by animals; Slaughter and McConnell (2003) list gaze following, social referencing, imitation, mental state attribution, intentionality, intentional communication, referential communication, speech production, and language acquisition as joint attention behaviors in human infants. The conclusion here is that, for both animals and humans, joint attention is a difficult to define behavioral phenomenon that may combine any number of underlying cognitive processes; definitions are in large part dependent on the authors' own ideas, and the methods they use to study it.

2.2.3.6 Autism

There is a large body of research dedicated to describing the relationship between autism and joint attention, some of it focused on the neural substrates of joint attention and their psychopathology in persons with autistic spectrum disorders; this will be covered in section 2.2.3.7. It has not, however, been my intention to provide a full review of joint attention and autism here; although many reports of behavioral studies concerned with autism do have direct relevance to joint attention in animals, and this has been highlighted throughout this review where applicable. As a general rule, scientists studying joint attention in autistic children and those working with animals often adopt dissimilar criteria for its definition. The list of behaviors (mentioned above) described by Slaughter and McConnell (2003) are typical of those behaviors relevant to joint attention in autism, and tend to include a far greater spectrum of behaviors than those common to comparative psychologists. This is predominantly evident from the literature pertaining to diagnosing autism in young children (e.g., Bruinsma *et al.*, 2004; e.g., Dawson *et al.*, 2002b; Lord *et al.*, 2000), or describing joint attention deficits and their relationship to language acquisition. In particular, those behaviors that precede or are associated with intentional communication and declarative acts; for example, protodeclarative pointing, point following, sharing, showing, joint play, pretend play, joint action, etc. (Charman,

2003; Sebanz *et al.*, 2006). Because normal human development ultimately results in full blown theory of mind and language acquisition, it can be difficult to systematically separate those skill sets that isolate normal infant development from the development of autistic children and the development of animals. In brief, infants with autism are able to a) detect the gaze of another agent, b) follow the direction of gaze of another agent, c) understand the intentions of certain behaviors of agents, but can not a) use gaze monitoring behaviors to the same extent as a normal infant, b) direct the attention of another agent to an object, c) attribute mental states to another agent, or d) attribute knowledge and beliefs to another agent. This ultimately leads to deficits in full-blown theory of mind, social perception, and language acquisition.

For animal experiments, results are equivocal as to where they fall along this continuum of skills, and as to whether or not they could ever develop these skills in the first place. Many animal species can a) detect the gaze of another agent, b) follow the direction of gaze of another agent, whereas only some species may, a) understand the intentions of certain behaviors or agents, b) use gaze monitoring behaviors to the same extent as a normal infant, and there is controversy as to if animals can a) direct the attention of another agent to an object, b) attribute mental states to another agent and c) attribute knowledge and beliefs to another agent. It is generally accepted however that no non-human animal species has full-blown Theory of Mind. I will, at this stage, avoid a lengthy discussion of autism, the ontogeny of linguistic communicative acts in infants and its relationship to joint attention, as this is not immediately important to animal studies, and in particular echoic eavesdropping in dolphins. However, an exception will be made for pointing behaviors (see section 2.2.4), as, in the case of dolphins and echoic eavesdropping, this is a potentially central behavior.

2.2.3.7 Neural Correlates of Joint Attention and Mirror Neurons

The neural correlates of eye detection and gaze following were previously discussed in section 2.2.2.2, however, in addition to these accounts, researchers have pinpointed neural correlates for behaviors and cognitive mechanisms associated with joint attention; for example, mental state attribution, goal oriented action and intentions. As a general observation, there appears to be a difference between the way a brain responds to a simultaneous attention scenario, and a joint attention scenario (involving the aforementioned cognitive processes) as witnessed by a series of recent neuroimaging and neuroresponse experiments. An event-related potential (ERP) test of infants around 9 months old found a larger negative component peak amplitude recorded when the child viewed an object after having first engaged in a joint attention (involving gaze following) relationship with an adult (Striano *et al.*, 2006), and not when the child simply attended to the same object as an adult. This suggests that infants have a general increase of attention and brain activity when participating in a joint attention scenario. Other studies have provided much more detail as to the specific brain regions involved in joint attention. As described previously, cells in the STS and the amygdala are sensitive to eye gaze cues. It has been proposed that the amygdala, a brain region central to the processing of emotion, may function to bind emotional content with sensory information; in the case of joint attention, sensory information related to eye detection and eye gaze (Adolphs *et al.*, 1999). Baron-Cohen and Ring

(1994) proposed that linking gaze cues to emotional response may be related to the ability to attribute mental states (e.g., emotions, 'seeing') to others, a critical component of the 'rich' view of joint attention. This is related to the idea of 'social referencing' (Slaughter & McConnell, 2003); a process whereby a subject learns a specific emotional response to an unknown object or situation by observing the emotions of another agent. This process is dependent upon joint attention, as the subject is required to map the response onto a specific object as referenced by the agent. It has been debated as to whether the imitation and therefore learning of an emotional response through social referencing is the result of the subject's ability to infer mental states, or a more simplistic mimicry ability (see discussion by Slaughter & McConnell, 2003). Whatever the underlying causes, the amygdala is tied to, and perhaps may 'amplify' the brain's response (STS cells in particular) to eye gaze cues (Leonard *et al.*, 1985). Some experimental evidence revealing significant impairment to a human's ability to reason about mental states and gaze due to damage to the amygdala (Fine *et al.*, 2001) may suggest that the amygdala plays a central role in gaze processing and mental state attribution.

Pelphrey's lab at Duke University has produced striking evidence at the neurological level that a joint attention scenario is likely contingent upon cognitive functions related to intentions and mental state attribution, as evidenced from functional neuroimaging (fMRI) studies on humans. In one study (Pelphrey *et al.*, 2003), adult human subjects were scanned in an fMRI while being shown an animated female character that shifted eye-gaze to either look at an object, look at empty space, or did not shift eye gaze. The act of looking at the object was equivalent to an intentional/goal directed act, and was hypothesized to cause more brain activation than scenes where the character looked at empty space. This was in fact found to be the case; activation of cells in the STS region, the intraparietal sulcus (IPS) and the fusiform gyrus (FFG) were all correlated with the 'gaze perception' scenario. This is an important finding; it means that the above brain regions, and in particular the STS region, are not simply eye or attention-detection regions, but seem cued to a behavioral context. The extra activation suggests that there is 'something else' occurring in the brain during these triadic relationships resulting from a gaze shift. The 'something else' may be related to intentions and goal-directed movements. In other trials, the subjects were shown a scene where the character either looked toward or away from an object presented in her field of view. There was increased activation during the 'wrong direction' scenario (i.e., looked away from the object), suggesting that the character had violated an expected behavior, placing extra processing demands on these regions, and suggesting that there must be inherent goal-directedness to the gaze shifting behavior. A lean interpretation may regard this as a system meant to uncover goal-directed behavior, whereas a rich interpretation may lump these regions in with a system designed for social perception, mental state attribution and Theory of Mind. A similar experiment had produced comparable results for younger subjects (children between 7 and 10 years) (Mosconi *et al.*, 2005). This 'functional dissociation' effect has also been documented in experiments where subjects viewed a grasping hand that was either directed toward or away from an object (Pelphrey *et al.*, 2004a). For these experiments, results of STS activation were similar to the 'wrong direction' scenario described above. A subsequent test (Pelphrey *et al.*, 2004b) revealed that STS activation was higher in scenarios where a subject was shown a

virtual reality image of a man shift his gaze toward them ('mutual gaze') rather than away from them ('averted gaze'); leading the authors to conclude that STS regions may code social cognition and social perception within the context of human behavior. Interestingly, in a study of autistic subjects (Pelphrey *et al.*, 2005) using the same paradigm as the 'wrong direction' test, activation was seen in the STS region, but it was equally as strong for both scenarios. This suggests that the 'violation of expectation' activation is not present in subjects with autism, congruent with a general deficit in social perception for autism. It is important to note that Carpenter *et al.* (2001) found that children with autism did not suffer from a lack of intentionality detection, suggesting that the above result might indicate a social perception role of STS cells that is more closely related to mental state attribution and Theory of Mind than a simple 'intentionality detector'.

In a review of the brain regions important to social cognition (including joint attention) Saxe (2006) describes cells in the STS as being related to interpreting goal directed actions in relation to gaze, but also a region in the temporo-parietal junction (TPJ) which, in humans but not other animals, is active when a subject must form 'representational' mental content; ideas about another agent's beliefs (a Theory of Mind ability). The TPJ also appears activated when a subject is asked to imagine how a scene would look from the visual perspective of another (Aichhorn *et al.*, 2006), possibly indicating a neural correlate for attributing 'seeing' to another agent. Also mentioned by Saxe, the medial prefrontal cortex (MPFC), once traditionally thought to be the 'seat' of Theory of Mind, allowing a subject to represent and reason about mental state of others, is no longer thought to be recruited in tasks relating to belief (as described for the TPJ). Instead, the MPFC has been subdivided into two regions related to social cognition; the ventral MPFC (integral to emotions and empathy) and the dorsal MPFC (representing shared collaborative attention and goals). This ability, argued by Saxe to be present only in humans, allows for a joint attention scenario where both agents are able to interact with an object based on their understanding of each other's intentions and mental states. The dorsal MPFC has been implicated in the monitoring of others' actions; specifically when observing collaborative actions between two characters (Walter *et al.*, 2004). The dorsal MPFC also appears to be recruited when a human subject plays a computer game against another human, but not when playing against the computer itself (presumably because there was no 'second agent' to involve in a triadic relationship (Rilling *et al.*, 2004)).

In a direct test of the neural correlates of joint attention, Williams *et al.* (2005) showed video clips of a joint attention and a control condition to subjects during an fMRI scan. The joint attention condition depicted a human character moving his eyes toward an object, a condition that purportedly "engendered an experience of joint attention in observers who watched them" (Williams *et al.*, 2005, p. 134). The control condition showed a similar scene with similar eye movements, but the subject's focus of attention was not on the object. The test subjects were asked to follow the movements of the object in the video; the human character in the video either simultaneously following the ball with them (joint attention) or was observed looking in some other direction (control). The hypothesis was that there would be more neural activity in the joint attention condition than the control condition.

Both conditions elicited activity in the superior temporal gyrus, the cingulate gyrus and areas in the right inferior and superior lobe. However, in the joint attention condition, a number of other brain areas registered activity including major activation in the right ventrolateral prefrontal cortex and the right anterior frontal lobe, and some activation in the cingulate cortex, bilateral caudate nuclei, and the right anterior frontal lobe. Given the activation in the MPFC, an area (as mentioned above) thought to be important to both joint attention and Theory of Mind as discussed by previous functional imaging tests (e.g., Dawson *et al.*, 2002a), the authors concluded that joint attention may, like Theory of Mind, activate brain areas thought to serve mentalistic functions. This could be direct evidence that a simple joint attention scenario, at least in healthy adult humans, is inseparable from those processes that govern complex mental state attribution. The activation in the left superior frontal gyrus (BA10) was hypothesized to be related to executive function capable of integrating separate cognitive operations at an abstract level; a process perhaps vital to a joint attention scenario where tracking the intentions/mental states of both the subject and the agent simultaneously is required.

Some authors have discussed the important relationship between mirror neurons and the neural correlates of joint attention (e.g., Villalobos *et al.*, 2005). Mirror neurons are a class of visuomotor neuron originally discovered in the ventral premotor cortex (area F5) of the monkey brain that are integral to both action understanding and imitation (Rizzolatti & Craighero, 2004; Rizzolatti *et al.*, 1999). In area F5, mirror neurons respond to object directed action triggered by visual stimuli; in particular, mouth and hand movements, especially grasping movements (Raos *et al.*, 2006). Importantly, mirror neurons are active both during the observation of these movements, and during performance of the motor response itself. Cells found in the STS have also been shown to be responsive to the observation of goal-directed hand movements (as well as eye movements as discussed previously), but do not respond during the execution of these movements; that is, they lack motor properties (see discussion by Rizzolatti & Craighero, 2004). Mirror neurons are thought to facilitate the ability to imitate observed actions (Jeannerod, 1994). The system also directly represents motor actions exhibited by another agent, leading to action knowledge (Rizzolatti & Luppino, 2001).

In Villalobos *et al.*'s (2005) discussion of mirror neurons, autism and joint attention, they describe an area in the human brain (area 44 – Broca's area), that has been described as homologous in function to the F5 system in the monkey brain; it codes action observation and imagery (see Buccino *et al.*, 2001). Deficits to the human mirror neuron system have been implicated in the impairment of imitation and joint attention abilities of people with autism (Charman, 2003; Williams *et al.*, 2004). This is related to the fact that area 44 is part of the dorsal stream of the MPFC; an area, as discussed above, vital to the mentalistic functions that facilitate joint attention in humans. Evidence from fMRI experiments has revealed that area 44 is affected in people with autism (Villalobos *et al.*, 2005). It is possible to conclude from this that mirror neurons are directly responsible for producing the kind of mentalistic processes (e.g., mental state attribution) that support joint attention, allowing one to extrapolate that their presence in monkey (and presumably other animal brains) is neurological evidence of a 'mental state attribution' mechanisms for animals. This argument, however, relies on a series of theoretical

'leaps of faith' citing potentially analogous mirror neuron systems in the human and animal brain, and potentially analogous behavior between autistic human and animal joint attention behaviors, and, therefore, may not be direct evidence of neural correlates for joint attention in animals. Emery (2005) argued that mirror neurons are likely only a small subset of the system of brain areas possibly involved in the 'social cognition pathway' for animals (possibly requiring the interaction of the amygdala and STS), and, by themselves, are unlikely to reveal the whole picture when it comes to joint attention.

Fogassi *et al.* (2005) described an experiment revealing activation of motor neurons in the inferior parietal lobe (IPL) of the monkey brain during both the observation and execution of different kinds of motor acts. The IPL is theorized to be a site of sensorimotor integration – combing multi-modal sensory input with motor action representation. Various individual neurons in this area responded differently to two motor action conditions. In one condition, the monkey grasped for a piece of food, brought it to the mouth and ate it. In the second condition, the monkey grabbed food (or an object), placed it in a container next to its mouth, and was subsequently rewarded with food. Some neurons were more strongly activated in the first condition, and a different set of neurons was more active in the second condition. What is striking about this result is that some neurons appear to code the exact same act in a different way depending on the final goal of the action. The act of grasping the food and starting to move it in a specific direction elicited different response in the same neuron depending on the 'ultimate' goal of the action. The role of this mirror neuron system then may be to understand the goal and intentions behind the observed motor acts of others. This relatively simple mechanism gives a powerful 'predictive' ability to this small set of neurons, perhaps allowing them to read the intentions of other agents (see discussion by Fogassi *et al.*, 2005). This might be evidence of the neurological correlates of an 'intentionality detector'. A study of eye-hand coordination in humans found that, in a block-stacking exercise, an observer's gaze was directed to an area where they predicted that the next hand movement of the stacker would take place, suggesting that the observer was predicting the intentions of another agent (Flanagan & Johansson, 2003). In a related experiment in monkeys (Kohler *et al.*, 2002), important to a discussion of dolphin echolocation, 15% of motor neurons that responded to the observed action of a hand ripping a piece of paper, also responded to the sound of the paper being ripped without the visual stimuli, leading the authors to identify a subset of 'audio-visual' mirror neurons within the mirror neuron system. This may be evidence suggesting that the system is correlated with action understanding, and understanding of goal directed action. Other authors have discussed how cells in the STS are sensitive to intentional action prediction; the relationship between the observed action and the environmental context in which it is expressed; activation in the STS was recorded when an observed watched a violation of expected 'intended' action or outcome (Grezes *et al.*, 2004; Saxe *et al.*, 2004). Studies of shared task abilities in humans have shown activation in various brain regions including the ventral premotor cortex when subjects were representing and predicting the actions and intentions of other agents (see review by Sebanz *et al.*, 2006). In summary, these neurological experiments have begun providing positive evidence of the physical presence of some of the many proposed mechanisms involved in joint intention, including

brain regions that may be directly involved in mental state attribution and intentionality.

2.2.4 Referential pointing

As discussed earlier, pointing behaviors are often linked with joint attention; primarily in discussions of joint attention in infants and its relationship to human language, where referential pointing is a behavior considered central to language acquisition. By some authors' accounts, pointing is a behavior that may even characterize the presence of a state of joint attention in animals (e.g., Kumashiro *et al.*, 2003), although it is typically discussed as a discrete act. Pointing has been singled out as a critical class of behavior that led to the evolution of language in humans (see discussion by Place, 2000). There are, however, a variety of potential underlying cognitive mechanisms involved in a range of different types of pointing behaviors (organized somewhat hierarchically). On the whole, the concept of 'pointing' suffers from similar theoretical problems as the concept of 'joint attention'; that is, there is a variety of related terminology used interchangeably with no agreed upon definition, there are a variety of mentalization abilities that might or might not be in play, and there is conflicting evidence from animal experiments as to how animals use pointing behaviors and what this means vis-à-vis cognition. The act of pointing can be defined in a number of ways, and has many potential synonyms. Pointing has been termed 'manual deixis' (Leavens, 2004b), 'referential pointing' (Call & Tomasello, 1994), 'deictic gesturing' (Herman *et al.*, 1999), 'manual pointing' (Krause & Fouts, 1997), and 'indexical pointing' (Leavens *et al.*, 1996). Pointing may also take many forms, for example, the whole hand point vs. the index finger point (see section 2.2.4.3) (Leavens & Hopkins, 1999). Pointing is generally thought to be distinct from 'reaching' due to its categorization as a 'communicative act' (Leavens *et al.*, 2005), although there is debate as to whether or not it is an 'intentionally communicative act' (Leavens, 2004b). There are two central cognitive concepts that are also related to pointing; 'reference', and 'intentional communication' – these terms will be discussed in section 2.2.4.1, and section 2.2.4.2 respectively. Most authors describe two distinct classes of pointing which will be discussed here; 'imperative pointing' (section 2.2.4.4) and 'declarative pointing' (section 2.2.4.5). The differences between these kinds of pointing behaviors, their relationship to reference and intentional communication, and evidence for pointing behaviors in animals (see section 2.2.4.6) will be discussed. This discussion is vital to the idea of echoic eavesdropping, as many authors have cited the intimate relationship between echoic eavesdropping, joint attention and a dolphin's ability to understand human pointing gestures (e.g., Herman *et al.*, 1999; Pack & Herman, 2004; Xitco *et al.*, 2004).

2.2.4.1 Reference

The term 'reference' or 'referential' is often encountered when describing communicative acts in both humans and animals. There are, however, two different usages of this term which should not, but occasionally are, confused. The first, and perhaps most common usage is that of 'symbolic reference'. Symbolic reference denotes the use of a sign or symbol to 'stand in' for a concept or idea. In human language, words or 'verbal labels' refer to objects and ideas that may not necessarily be present during an act of communication - a linguistic property termed 'displacement' (Leavens, 2004b). These labels

refer to what is termed a 'referent'. This is a common component of human language (Hockett, 1960), and is the basis for artificial language comprehension experiments involving animal species, for example, experiments with chimpanzees (Savage-Rumbaugh & Rumbaugh, 1978), dolphins (Herman, 1985), and parrots (Pepperberg, 1987). There is also mounting evidence that both un-trained captive and wild animal species use vocalizations as referential labels (alarm and food calls), for example, Diana monkeys (Zuberbuhler, 2000), chimpanzees (Slocombe & Zuberbuhler, 2006), meerkats (*Suricata suricatta*) (Manser *et al.*, 2002), and vervet monkeys (Seyfarth *et al.*, 1980a; Seyfarth *et al.*, 1980b). It has been hypothesized that dolphin species may develop a signature whistle that is used to 'refer' to themselves and other individual dolphins (Janik *et al.*, 2006; Sayigh, 2002). 'Symbolic reference' is important to a discussion of animal communication, but it is not pertinent to a discussion of referential pointing. The second usage of the term 'referential' in the phrase 'referential pointing' is not synonymous with 'symbolic reference'. This usage of 'referential', sometimes referred to by comparative psychologists as 'nonverbal reference' (Leavens *et al.*, 2004), could be defined as 'a communicative act that is intended to direct the focus of attention of another agent toward something of interest; an object or event'. In this sense, a pointing gesture does not 'stand in' for the object that is the focus of attention (Leavens, 2004b); a 'referential point' is an act that directs the visual attention of another to an object, it is not a symbol that represents (or refers to) the object itself. The same pointing gesture can obviously be used to 'refer' (direct attention) to an unlimited number of objects or events. In summary, the two terms are; 'symbolic reference' (a sign that 'stands in' for a concept), and 'pointing reference' (an act that directs the attention of another).

2.2.4.2 *Intentional Communication*

A definition of 'intentional communication' suffers from many of the same problems as a more general discussion of 'intentionally' (see section 2.2.3.3). Leavens (2004b) distinguishes between two working definitions of 'intentional communication' in relation to referential pointing. The first definition assumes that a communicative act (like pointing) occurs because the subject 'intends' to manipulate the behavior of another agent. This presupposes that the subject may have both a) unobservable intentions/goals/desires and b) intentions directed toward the psychological states of other agents – similar to the previously discussed concepts of 'prior intentions' and 'communicative intentions' (Searle, 1983). As other authors have pointed out (e.g., Emery, 2005), testing for the presence of these kinds of intentions is 'unverifiable in practice' (Leavens, 2004b, p. 390). However, a second definition of 'intentional communication' is adapted from the literature pertaining to the study of preverbal communication in infants, and includes the establishment of four criteria:

1) audience, 2) monitoring, 3) attention getting, and 4) persistence. The first criterion (audience) is fulfilled if the communicative act is produced in the presence of other agents, and if this act is shown to be more likely to be produced when these agents are present. The second criterion (monitoring) involves the active checking of the attentional state of the other agents, equivalent to gaze monitoring as described previously (see section 2.2.3.1). The third criterion (attention getting) requires the subject to actively produce attention getting behaviors (visual displays, vocalizations, etc.) in the event that the intended recipient of the communicative act is either unresponsive or has averted attention. The

fourth criterion (persistence) involves the subject persisting in producing the communicative act in a situation where other agents are non-responsive or where the communicative act has otherwise failed to produce the desired response. Agents potentially involved in an intentionally communicative act must then have an understanding of what has been previously described as ‘intention in action’; the ability to infer the intentional nature of certain behaviors, and to integrate these inferences with knowledge about another agent’s attentional states. The establishment of these four criteria differentiates an intentionally communicative act from a simple communicative act, which is limited to the production of a communicative signal without reference to the attentional or intentional states of other agents. For example, a passerine bird engaging in a bout of singing is producing simple communication; although the singing is obviously a communicative act that will influence the behavior of other agents, it is performed without regard to the observed behavioral intentions or attentional states of those agents. In contrast, a piping plover (*Charadrius melodus*) that engages in a ‘broken wing’ display in the presence of a predator satisfies all four criteria (see description in Bekoff & Jamieson, 1996), and thus could be considered engaging in an intentionally communicative act. Note that this does not assume that the plover has an understanding of the ‘prior intentions’, mental states or beliefs of the predator in question, rather that it has an understanding of the predator’s behavioral intentions (e.g., is approaching my nest) and attentional state (e.g., focused on me vs. focused on my nest). There is, however, debate in the literature about, in the case of animal pointing, when and if these criteria have been met, and whether or not different kinds of pointing could be considered intentional acts.

2.2.4.3 Structure of pointing

Pointing is a behavior considered to be universal for the human species (Bates *et al.*, 1987; Povinelli & Davis, 1994). Pointing is traditionally considered an act consisting of the extension of a finger (usually the index finger) together with a raised and extended arm moving in the direction of an object that is the focus of attention of the point/subject. This definition obviously limits pointing behaviors to animals (usually primates) that have anatomical structures capable of producing a point (e.g., flexible forelimbs and dexterous fingers). Some authors have pointed out that chimpanzees may in fact be less likely to produce a point given the anatomical constraints of the chimpanzee hand; that is, a hand morphology which is more likely to retain a closed-hand form than an extended finger form (Povinelli & Davis, 1994). This may explain the data showing a reduction of finger-point production in language-trained chimpanzees otherwise capable of understanding the human pointing gesture. Some authors have criticized this explanation, noting that whole hand and indexical pointing are open to context that may influence their production (Leavens, 2004b), and so hand morphology is not enough to explain variability in pointing behaviors for chimpanzees. Pointing with the whole hand (i.e., with all finger extended equally) is a structure common to both great apes and human infants, and has been considered a functionally discrete act. Whereas indexical pointing (using the index finger) is considered a referential act, whole hand pointing is hypothesized to serve as a request for an object or request for an action on an object (Butterworth, 2003). This suggestion has influenced the debate as to the function of pointing in non-human animal species, as will be outlined in section 2.2.4.6.

2.2.4.4 Imperative Pointing

Imperative pointing (sometimes referred to as protoimperative pointing) is a point that has the function of requesting others to act on an object or location (Baron-Cohen *et al.*, 1999a). The term ‘protoimperative’ was coined to refer to the pre-linguistic requestive (imperative) behaviors of human infants (hence ‘proto’), and is a term that, therefore, is not relevant to non-linguistic animal species (Bates *et al.*, 1975; Leavens, 2004b), and so I will use the term ‘imperative pointing’ in this review. It has been proposed that imperative pointing occurs without a subject’s reference to or knowledge of another agent’s psychological states. Imperative pointing then does not occur during a joint attention scenario, as it does not involve those abilities that separate STA from ‘rich’ joint attention; that is, mental state attribution, gaze monitoring and intentionality. Instead, an imperative point functions to manipulate the behavior of other agents without reference to their mental or attentional states, described by Leavens and Hopkins (1998, p. 820) as follows: “protoimperative pointing in humans serves a requisite function: a social agent is instrumentally manipulated to achieve some goal involving an object or location, and this is held to constitute a manipulation of another’s *behavior*.”

2.2.4.5 Declarative Pointing

In contrast to imperative pointing, declarative pointing is an act that attempts to direct the attention of another agent to a particular object, establishing a state of joint attention (Baron-Cohen *et al.*, 1999a). This may or may not be driven by a desire of the subject to obtain the object, nor have the other agent act on the object in some way, rather is merely an attempt to share attentional states with the agent; “to comment or remark on the world to another person” (Baron-Cohen, 1989, p. 118). Unlike imperative pointing, it is often assumed that a subject engaging in declarative pointing has an understanding of the psychological states of others (mental state attribution, attribution of intentionality) and possibly might indicate full blown Theory of Mind (Tomasello, 1999). As declarative pointing appears to develop later in human infants (Leavens, 2004b), it is often linked with the development of more complex social communicative skills possibly reliant on richer mentalization abilities, summarized by Leavens and Hopkins (1998, p. 820) as follows: “protodeclarative pointing establishes a state of joint attention, and this is generally construed to manipulate another’s mental state.” Imperative pointing has been described as a behavioral act consistent with what some authors describe as ‘initiating behavior regulation’ (IBR), whereas declarative pointing is part of a group of behaviors associated with ‘initiating joint attention (IJR) (Henderson *et al.*, 2002; Wetherby *et al.*, 1988). Much like joint attention, there is a gray area involved in a discussion of a subject’s understanding of the ‘psychological states’ of other agents in a pointing scenario. A declarative vs. imperative pointing distinction may suffer from the same problems as an STA vs. rich joint attention distinction; there are numerous approaches to subdividing the underlying cognitive mechanism of ‘intentionality’ (e.g., ‘intention in action’ vs. ‘prior intentions’) and ‘mental state attribution’ (e.g., understanding ‘attention’, ‘seeing’ and ‘belief’). Some authors (Miklósi & Soproni, 2006) have proposed a middle ground interpretation of pointing gestures; one where an animal may understand pointing as an intentionally communicative act (presumably focused on an object), but doesn’t require them to represent mental states. This debate will be highlighted in the following section (2.2.4.6.). In a

later, more ‘modern definition’ of declarative pointing, Leavens (2004b, p. 293) discards the notion of mental state attribution, and considers declarative pointing to be an act intended to “share attention to distant objects or events” that does not necessarily require the subject to conceptualize another agents’ “abstract mental states”. According to this definition, there are no ‘cognitive’ differences between imperative and declarative pointing, only behavioral ones.

2.2.4.6 Pointing in Animals

For humans, indexical imperative pointing develops at around 12 months of age (Carpenter *et al.*, 1998; Liszkowski *et al.*, 2004), and is considered to be full-blown declarative pointing at 24 months (Bates *et al.*, 1977). Infants are able to follow pointing gestures at 9 months, but not earlier (Miklósi & Soproni, 2006). There is, however, highly controversial evidence demonstrating the ability of animal species to both produce and comprehend this gesture, either as an imperative or declarative point. Miklósi and Soproni (2006) provide a review of pointing comprehension experiments involving a variety of animal species: Rhesus monkeys, capuchin monkeys (*Cebus apella*), chimpanzees, gorillas, orangutans, dogs, wolves (*Canis lupus*), cats (*Felis catus*), dolphins, horses (*Equus caballus*), seals, and goats, have all been tested for their ability to comprehend the human pointing gesture. Miklósi and Soproni’s discussion highlights the fact that an interspecies comparison is seriously compromised by inconsistencies in methodology used by the experimenters working with the above species. Variations in experimental design (e.g., distance to target object, proximity to researcher, structure of training period), variation in behaviors used as ‘pointing’ behaviors (e.g., static vs. dynamic point, cross-body points), and problems controlling for accompanying/extraneous cues (e.g., gaze cues) make comparisons problematic. In addition, the authors point out that these studies generally rely on a very small pool of subjects, raising concerns of external validity. Furthermore, for many of the human-reared or human-trained animals used in pointing experiments, it is all but impossible to control for inadvertent previous ‘training’ that a subject might have had been exposed to; that is, normal human behavior that undoubtedly involved the use of the human pointing gesture.

With methodological concerns a prominent problem, it is little wonder that a review of the animal pointing comprehension literature yields much confusion. Povinelli and colleagues’ research consistently produced limited results of pointing comprehension by chimpanzees. Although some studies revealed that chimpanzees were able to respond to proximal points (points to objects in close proximity to the researcher), chimpanzees had a difficult time understanding distal pointing (Barth *et al.*, 2004; Povinelli *et al.*, 1997b). These authors argue that any success on the part of the chimpanzee in using the pointing gesture to find an object/reward is likely due to generalized associative learning about the experimental conditions and not comprehension of the referential nature of a pointing gesture. This is likely comparable to Povinelli *et al.*’s (1999) ideas about ‘low level’ interpretation of pointing comprehension; one where learning simple rules about behavioral states is all that is required. That is, there is no need for reasoning about mental states, or referential signals in order to understand pointing. Similarly ambiguous results of pointing comprehension by gray seals (*Halichoerus grypus*) (Shapiro *et al.*, 2003) led the authors to posit that, like Povinelli *et al.*’s suggestions, seals were using

signal generalization coupled with initial operant conditioning training to understanding pointing gestures; they had not understood the referential nature of the signal itself. It has been posited that an animal may be cued to the direction of food in these experiments simply by looking toward the presence of a moving hand involved in pointing (due to the tracking of movement), causing the animal to begin orienting in the direction of the object/reward, thus eliminating the need for pointing comprehension of reference in trials where animals are successful at proximal point comprehension (Miklósi & Soproni, 2006; Tomasello *et al.*, 1998). Successful trials appear to be the result of the point being produced within close proximity to the object (e.g., <50 cm) (Miklósi & Soproni, 2006), lending weight to this argument (e.g., Call & Tomasello, 1994). It is possible that a learned rule like 'choose the object closest to the researcher's hand' may explain the results of most pointing experiments (see discussion by Povinelli *et al.*, 2000).

Positive results found by some researchers for chimpanzees and orangutan on object-choice tasks (Call & Tomasello, 1994; Itakura, 1996; Itakura & Tanaka, 1998), can be contrasted with conflicting results (Itakura *et al.*, 1999; Tomasello *et al.*, 1997) on similar tasks, highlighting the point made by Miklósi and Soproni (2006) concerning methodological differences. For example, in some experimental paradigms (like those employed by Povinelli and colleagues), researchers tend to avoid eye contact with either the subject or the object while pointing (e.g., Povinelli *et al.*, 1997b). In this experimental scenario, negative results are usually attained. In contrast, the positive results obtained by other authors (e.g., Itakura *et al.*, 1999) seem to be a correlated with the use of pointing gestures in combination with eye gaze and eye monitoring behaviors on the researchers' part. Similar conflicting evidence exists for other primate species. Experiments intended to test primates' abilities to follow the attention of a researcher showed a positive orienting response in relation to pointing gestures for Japanese monkeys (Kumashiro *et al.*, 2002; Kumashiro *et al.*, 2003), cotton top tamarins (*Saguinus oedipus*) (Neiworth *et al.*, 2002), white handed gibbons (*Hylobates lar*) (Inoue *et al.*, 2004), and Capuchin monkeys (Anderson *et al.*, 1995; Vick & Anderson, 2000b), but no such responses for Rhesus monkeys (Anderson *et al.*, 1996; Hess *et al.*, 1993), and nine other species of lemur and monkey (Itakura, 1996). Again, a mixture of gaze and other extraneous signals were used during some of these experiments, making it difficult to determine the animals' responses to pointing gestures in isolation. In other experiments, enculturation and long term exposure to human behavior were cited as mitigating factors (Itakura, 2004; Miklósi & Soproni, 2006). Despite some limited success, it is generally accepted that chimpanzees and other primates do not spontaneously perform above chance level on object-choice tasks involving the pointing gesture unless subjected to repeated trials, enculturation, human socialization, additional attentional cues, and/or intense training (Brauer *et al.*, 2006; Hare *et al.*, 2002; Itakura & Tanaka, 1998; Kaminski *et al.*, 2005; Miklósi & Soproni, 2006).

In contrast to these equivocal results, and despite the evidence that wolves have also performed poorly on object-choice tasks involving pointing cues (Brauer *et al.*, 2006; Hare *et al.*, 2002), dogs appear particularly skilled at understanding pointing gestures. Dogs have been documented as performing exceptionally well on object-choice tests where they were able to follow the human pointing gesture

to both proximal and distal objects (Miklósi *et al.*, 1998; Miklósi *et al.*, 2005; Soproni *et al.*, 2001), even at young ages (Agnetta *et al.*, 2000). This is in stark contrast to the performance of the great apes. A direct test of dogs vs. apes in the object-choice task was performed by Brauer *et al.* (2006). In this object-choice test, dogs, chimpanzees and bonobos were presented with a choice between two containers, one of which has a hidden food reward. One of three classes of cue was then given by the researcher in reference to the correct choice: communicative (e.g., pointing, gazing), behavioral (e.g., reaching, attempting to open container), and causal (e.g., shaking the cup so the food reward rattled). Dogs were able to use the communicative cues to find the reward, whereas apes had difficulty. Apes on the other hand were able to use the causal cues, whereas the dogs had difficulty. It has been proposed that the pointing gesture may not be a salient cue for apes in the same way that it appears to be for humans and dogs (Brauer *et al.*, 2006). Although chimpanzees do appear to be capable of understanding the goal directed act of reaching for an object (Hare & Tomasello, 2004), in general, they do not seem able to understand the referential act of pointing. It has been hypothesized (Brauer *et al.*, 2006) that apes may be highly skilled at inferring causal cues, whereas, in the case of pointing and gaze, dogs are highly skilled at inferring social cues. The reason for the emergence of these abilities in dogs (and lack thereof in wolves) may be related to their history of domestication; dogs may have been selectively bred to be responsive to human communicative gestures (Call *et al.*, 2003; Miklósi & Soproni, 2006). This is a similar explanation as that offered by Kaminski *et al.* (2005) for the performance of domestic goats on object-choice pointing tests, and may also be relatable to the positive evidence attained for a domestic horse in a similar test (McKinley & Sambrook, 2000).

With the exception of dogs, only one animal species has exhibited consistent results on pointing comprehension; the bottlenose dolphin. In an early study (Herman *et al.*, 1993), researchers tested dolphins participating in artificial language training tasks for comprehension of pointing. A researcher positioned floating in the middle of the dolphin's tank used a dynamic point to indicate the object upon which the dolphin was asked to perform an action. The dolphin responded with 81% accuracy (chance = 33%). This was achieved without training, although the dolphin did have extensive exposure to other sign/symbol training, and informally to pointing gestures. Similar results were obtained from later tests of the pointing gesture as incorporated in the dolphin's language training (Herman & Uneyama, 1999). Later studies of the same dolphins (Herman *et al.*, 1999) used a variety of points to refer the dolphin to objects in the tank; fully-extended arm and finger points (ipsilateral point), exaggerated point (including movement of the body in the direction of the point), and cross-body points (contralateral point - a novel pointing behavior). The dolphins were able to understand the object referred to by these points and use them correctly in their action sequences – even distally placed objects (positioned several meters away), with exception to those objects placed 'behind them', that is, out of their field of vision (for one of the two subjects). For additional trials, a combination of two points was used in order to refer to two separate objects involved in an action sequence (e.g., take THIS ball in THAT basket). Again, the dolphins were successful in these tasks, including the novel cross-body points. Unlike the results of primate studies, these results are a clear indication of a dolphin's ability to use the pointing gesture a means of directing their own attention to an object. The

fact that they could 1) use the point to locate distal objects, 2) incorporate pointing into their pre-existing symbolic language system, 3) understand pointing without extensive training, 4) combine more than one pointing gestures sequentially, and 5) understand novel (cross-body) points, indicates that dolphins may be skilled at understanding the referential nature of the pointing gesture. These results will be discussed in more detail in section 2.3.2.7. It has been argued that high levels of performance on early tests of pointing comprehension indicate that the subject could not have had time to ‘learn’ the meanings of these gestures (Miklósi & Soproni, 2006), supporting the claim that the dolphins understood the referential character of these signals. Notably, no animal other than the dolphin has been able to combine two or more points sequentially as reference to two or more objects. Also, the types of points used in these trials were ‘momentary points’ (Miklósi & Soproni, 2006); a more difficult point to comprehend than the static points often used with primates. While it is true that the two dolphin subjects involved in this study did have informal exposure to pointing gestures as part of their previous training routines, it is important to note that chimpanzees who had been likewise exposed to pointing throughout their lives were unable to spontaneously understand pointing to the same extent as these dolphins on similar tests (e.g., Povinelli *et al.*, 1997b).

These experimental results were replicated in a study of six dolphins performed by Tschudin *et al.* (2001). Unlike the dolphins in the Herman *et al.* (1999) study, these dolphins had no prior exposure to pointing gestures during training other than incidental exposure. In an object-choice task, researchers used a fully-extended arm point to indicate one of two possible objects located 120 cm on either side of the dolphin (gaze and ‘replica’ were also used to indicate the object). For the pointing gestures, 4 of the 6 dolphins were able to use this gesture to locate the correct object during these trials. As this was the first exposure these dolphins had to the pointing gesture, the authors conclude that the dolphins were able to spontaneously comprehend the meaning of the human pointing behavior. Pack and Herman (2004) performed follow-up object-choice test with the same dolphins used in the Herman *et al.* (1999) study. For these new tests, eye and head cues were studied in addition to pointing cues. For the pointing trials, the pointing cues were isolated from potential extraneous cues by placing an opaque white board in front of the researcher, obscuring the body and head so that only the arm, hand and pointing finger were visible. Both dolphin subjects were able to choose the correct object 100% of the time for these trials. The results of these experiments reveal that dolphins have an extraordinary ability to comprehend the meaning of the pointing gesture, something that, unlike dogs, can not be attributed to the influence of domestication (Miklósi & Soproni, 2006).

Pointing comprehension studies are often augmented with tests of an animal’s ability to produce pointing gestures. Similar to the controversy concerning mental state attribution for chimpanzees, the ability of primates to produce points (either imperative or declarative) is clearly divided into two camps. Some researchers (the ‘pro-pointing camp’) believe that apes (and some other primates) are able to produce declarative points; a form of intentional communication intended to manipulate the mental states of other agents that is characterized by gaze monitoring and attention getting behaviors, and is, by definition, a referential act (e.g., Krause & Fouts, 1997). There is, however, some dispute as

to what level of mental state attribution is associated with these behaviors as the views of the pro-pointing camp have evolved somewhat in the last decade. The ‘anti-pointing camp’, again led by the arguments of the Louisiana research ground (i.e., Povinelli and associates), argues that any primate pointing is a behavioral act that merely bears a resemblance to human pointing, and that it lacks any of the complex psychological mechanism that constitute human pointing (Povinelli *et al.*, 2003a). This debate helps to highlight many of the relationships between the cognitive underpinnings of pointing, observable behaviors, and the experimental and methodological difficulties in studying pointing in animals.

The anti-pointing group structures their arguments as to what constitutes pointing vs. non-pointing on two levels: the unobservable mentalistic level and the level of observable behavioral outcomes. For apes, they argue that pointing behaviors do not exist on either of these levels. Concerning observable behavior, there is no evidence for point production (either imperative or declarative) for chimpanzees in the wild (Leavens *et al.*, 2004; Povinelli *et al.*, 2000), or in concert with conspecifics in captivity (Povinelli *et al.*, 2000). Young chimpanzees in captivity do not produce pointing gestures (Povinelli *et al.*, 2000; Tomasello & Carpenter, 2005). Indexical pointing by apes appears restricted to animals that have been explicitly trained to use pointing during the enculturation process (Povinelli & Davis, 1994). The anti-pointing camp would likely contend that these are not true ‘pointing’ behaviors because these points do not influence the ‘internal mental states’ of the other agent (see discussion by Leavens *et al.*, 2004), an ability necessary for ‘declarative pointing’. Concerning mentalization, Povinelli’s research group (Povinelli *et al.*, 2000; Povinelli *et al.*, 2003a) has suggested that ‘argument by analogy’ is often inappropriately applied to pointing experiments. The notion that researchers assume that a behavior (extending arm/hand/finger toward object) in apes that resembles a behavior (pointing)- in humans is arrived at because of analogous mentalization abilities; that is, intentional, referential communication (declarative pointing). The authors argue that these similar behaviors may be arrived at through independent underlying mechanisms; on the part of the apes, natural behaviors that are structurally similar to pointing (e.g., reaching, food begging) may have been co-opted for use in pointing experiments with humans, but that these behaviors likely lack any mentalization abilities. The anti-pointing group would argue that the pointing behaviors observed for chimpanzees and other great apes in captivity during experiments with human researchers (e.g., reaching, open hand point, indexical pointing) are likely example of ‘imperative points’; that is, that these points are directed toward an object for the purpose of manipulating an agent’s behavior in relation to that object, but lack mental state attribution, gaze monitoring and intentionality, and/or that they are reinforced learned behaviors. These points may be referential insofar as they direct the attention of another agent toward an object, but do not necessarily imply an understanding of the mental states that could underpin the observable attentional states. Thus, when the anti-pointing group makes a claim that ‘apes do not point’, they are asserting that 1) apes in the wild do not engage in behaviors that resemble human pointing behaviors, and 2) when encultured apes do use pointing gestures in captivity, these are not ‘declarative points’. Other authors have made similar claims to the effect that apes engage in imperative pointing, but not declarative pointing (Baron-Cohen *et al.*, 1999a; Butterworth, 2001; Povinelli *et al.*, 2003b). For all of

the claims, imperative pointing is fundamentally different from declarative pointing due to the presence of mental state attribution.

The pro-pointing camp is best characterized by the research and writings of Leavens and associates, who maintain that apes do in fact point, despite the claims of the anti-pointing camp (see Leavens *et al.*, 2004). These authors refute both claims asserted by the anti-pointing group: the pro-pointing camp maintains that 1) there have been some pointing behaviors observed in wild apes and between conspecifics in captivity, and that 2) apes (and monkeys) engage in declarative pointing. Concerning the first claim, the pro-pointing group claims that there is some evidence for pointing gestures produced by wild chimpanzees (e.g., Inoue-Nakamura & Matsuzawa, 1997; Vea & Sabater-Pi, 1998), as well as anecdotal evidence of pointing between conspecifics in captivity (de Waal, 2000). They argue that pointing may not necessarily be a behavior learned from human trainers, as there is also evidence that pointing gestures arise spontaneously in captive apes without explicit training (e.g., Call & Tomasello, 1994; Tomasello & Call 1997), including indexical pointing (e.g., Leavens & Hopkins, 1998; Leavens *et al.*, 1996). The pro-pointing camp has supplied evidence that apes produce points more often in the presence of a human researcher, leading them to reject the claim that these behaviors are simply an attempt to reach toward an object (e.g., food reward) (Leavens *et al.*, 1996; Leavens *et al.*, 2004). The fact that the chimpanzees in these experiments gestured toward a food reward in the presence (or upon the imminent arrival) of a human researcher led the authors to conclude that this, when understood with the observed gaze alteration exhibited by the subjects, is an intentionally communicative act. However, the authors note that this definition of ‘intentional communication’ need not include intentions toward the mental states of other agents, rather simply an attempt to manipulate the behavior of other agents (Leavens *et al.*, 2004). This is in contrast to an earlier claim by the pro-pointing group (Leavens *et al.*, 1996) that “pointing constitutes *ipso facto* evidence for perspective taking” (see discussion Leavens, 2004a, p. 158); that is, that engaging in pointing can only occur if the animal is able to attribute mental states to other agents. This revised ‘modern’ position has been described in subsequent reviews (Leavens, 2004a; Leavens *et al.*, 2004). Thus, for the pro-pointing group, there is no longer a distinction between imperative and declarative pointing in terms of underlying cognitive function; neither type of point is necessarily arrived at through mental state attribution. This ‘modern’ definition of declarative pointing now simply asserts that it is a behavioral act on the part of the subject that is an attempt to direct the attentional state (not the mental state) of an agent to an object. However, unlike the anti-pointing camp, the pro-pointing group entertains the idea that this ‘modern definition’ of declarative pointing has also been observed both in captive and wild apes. Leavens (2004b) cites anecdotal evidence of declarative pointing gestures exhibited by language trained apes; (e.g., Savage-Rumbaugh, 1986; Savage-Rumbaugh *et al.*, 1998). One anecdotal observation from a wild bonobo (Vea & Sabater-Pi, 1998), using both pointing and gaze altering behaviors, has also been cited as supporting evidence for this claim. Leavens (2004b) also cited apparent declarative pointing in monkey experiments (Hess *et al.*, 1993; Kumashiro *et al.*, 2002; Kumashiro *et al.*, 2003). Unencumbered by the requirement of ‘mental state attribution’, this definition of declarative pointing includes any point-like behavior that functions to direct the

attentional state of another agent to an object.

The central issue in this debate is whether or not the subject is able to attribute mental states to the agent, and where this ability fits into a definition of imperative vs. declarative pointing. Both camps now firmly believe that point production is not evidence of mental state attribution. As has been discussed, an attentional state is something that can be inferred from the behaviors of another agent; an ape that varies pointing behaviors in relation to the changing attentional states of another agent need not be an ape that is aware of that agent’s mental state. Because many authors have historically lumped mental state attribution together with joint attention behaviors, and because joint attention behaviors are often lumped in with declarative pointing, this ‘modern’ view of declarative pointing (i.e., declarative pointing without mentalization) is not necessarily the norm. The anti-pointing camp may still argue that declarative pointing is, by definition, a kind of pointing that can ONLY occur if the subject is employing mental state attribution, and since pointing experiments can not reveal whether or not a point is caused by this underlying cognitive ability, no evidence yet exists that animals engage in declarative pointing. The pro-pointing group, adopting the modern view, argues that declarative pointing is directed at the behaviors and attentional states of the agent, and not the psychological states. This is now a matter of definition; both groups are claiming the same thing – that ape pointing experiments can not tell us anything about mental state attribution, but also that apes use pointing gestures. One group (pro-pointing) labels this declarative pointing, and one group (anti-pointing) labels this imperative pointing, or sometimes even ‘no pointing’. A summary of the structure and function of pointing that combines the views of both camps can be found in Table 2.1.

Table 2.1 Summary of pointing; structure and function

Pointing behavior	Structure	Function
Reaching	Extension of hand and arm in direction of desired object	Gain access to a desired object, irrespective of the presence or attentional state of other agents
Whole hand point	Extension of hand and arm in direction of desired object	Manipulate the behavior of another agent in relation to an object
Imperative point	Extension of hand and arm and index finger in direction of object	Manipulate the behavior of another agent in relation to an object
Declarative point	Extension of hand and arm and index finger in direction of object coupled with checking and attention getting behaviors	Direct the attention of another agent to an object

For both camps, the question of ‘mental state attribution’ is more or less off the table. The function of pointing behavior (as revealed experimentally) is focused on attentional states and not psychological states. With this middle ground established, this debate has entered a new phase; the current central topic has shifted from ‘do pointing animals attribute mental states’, to ‘will pointing experiments ever reveal anything about an animal’s ability to attribute mental states’. It is clear that the current experimental paradigms have elicited more questions than they have answered. Following this shift, Leaven’s recent work is now focused on the role that different levels of enculturation and contact with humans may play in the ontogeny of pointing behaviors for apes. The current hypothesis is that declarative pointing may develop more often when an ape is required to participate in attention sharing and object labeling tasks, as this type of pointing is reinforced by an emotional connection established during triadic relationships (Leavens, 2004b); tasks that closely mimic the development of language and social skills of human children. It is here that a fundamental difference is revealed between the study of pointing in animals, and the study of pointing in humans. For human infants and those with autistic disorders, the use of pointing behaviors is a potentially vital clue as to a subject’s ability (or inability) to attribute mental states. Whereas those involved in animal studies have left mental state attribution aside, this discussion is still a central theme for human studies. Some have argued (e.g., Povinelli *et al.*, 2003a) that whereas a point produced by a pre-verbal infant might be an indication of their sensitivity to mental states (because of the fact that humans are known to develop these sensitivities), the same point produced by a non-verbal animal is not evidence for this sensitivity. Leavens discarded this argument as ‘teleology’, and considers this ‘an argument that can never be addressed through empirical inquiry’. This disagreement highlights the methodological difficulties in being able to associate point production with mental state attribution for non-language using subjects. There appears to be a concrete link between the fact that children with autism have difficulty attributing mental states to other agents, and the fact that they do not (or very rarely) engage in acts of declarative pointing (Baron-Cohen, 1995; Mundy *et al.*, 1986), although this link is often borne out longitudinally – with final diagnosis awaiting the tests that can be administered after human language learning has begun. Still, as discussed earlier, the lack of production of declarative pointing is used in the early diagnosis of autism in young children. But as we have seen, a lack of pointing in animals is no longer considered a test of an animals’ ability (or inability) to attribute mental states.

Unfortunately, there are additional complications to understanding the links between point production and its underlying cognitive mechanisms in animal species. By all of the definitions we have encountered so far, pointing has focused on the use of the hand (manual deixis) as the core structure of the point. By these definitions, animals that do not have hands are incapable of pointing. The vast majority of literature on the subject of animal pointing concerns primates; however, the two animal species that have demonstrated the greatest comprehension of the human pointing gesture (dogs and dolphins) are not primates, and are species that do not have hands. There is, however, some evidence that these species are capable of producing points or point-like behavior despite this terminological complication. An obvious example are the breeds of dogs known as pointers or setters; animals that have been both bred and trained to freeze and orient their muzzle in the direction of potential prey

during human hunting expeditions (Hudson, 2004). Only a limited number of experiments have been conducted with dogs in order to determine their ability to produce pointing gestures. Miklósi *et al.* (2000) performed a series of experiments that examined dogs' abilities to engage in behaviors that are functionally equivalent to declarative pointing. The function of a point is to direct the attention of another agent to an object. In the case of manual deixis, this is accomplished by extension of hand, arm and index finger in the direction of an object coupled with checking and attention-getting behaviors. Given that dogs do not have the ability to extend an arm and fingers, an equivalent gesture must be used in combination with checking and attention-getting behaviors; for the Miklósi *et al.* (2000) experiment, this equivalent gesture is head orientation and gaze direction. Like a declarative point, this behavior is considered both referential and intentional communication if it is performed with regard to the attentional state of a potential receiver, and if it is accompanied by attention-getting behaviors. Dogs were tested in a series of conditions in order to measure their production of these types of behaviors. The results suggest that, in scenarios where both a food reward and a human were present in the same room with the dog, the dog was more likely to engage in what was termed 'showing behaviors', that is, altering gaze between the human and the food, and increasing barking rates. The fact that the dogs looked more often at the food reward in the presence of a human than in conditions where the food was present but a human was not, indicates that the act of looking (orienting head and gaze toward the food) may be a directional cue equivalent to a point. The authors argue that this showing behavior likely reveals that it is not simply a case of the dog's previous experience with being rewarded for exhibiting showing-like behaviors; the complicated combination of gaze-altering and attention-getting behaviors do not fit easily into a pattern of learned associations. Furthermore, they argue that gaze alteration and attention getting behaviors can not easily be explained as anticipatory behaviors; that is, general excitement about the possibility of a food reward, as these do not "predict the observed organized pattern of gaze alternation and vocalizations that emerges when both the owner and the hidden food are present" (Miklósi *et al.*, 2000, p. 165). This suggests that dogs are capable of understanding the attentional states of humans, and that they may have sensitivity to communicative behaviors of humans, presumably ultimately attributed to the process of domestication. Similar results were found in an experiment testing a dog's sensitivity to the attentional states of a human in object retrieval tasks (Hare *et al.*, 1998).

Without the ability to produce a manual point, tests for pointing behaviors in animals that do not have hands must always find analogous pointing behaviors, and understand these behaviors in combination with the types of behaviors that typically accompany declarative pointing, that is, those behaviors that are related to referential and intentional communication. Similar to the dog experiments, researchers working with dolphins reported such analogous behaviors. Xitco *et al.* (2001) reported the use of spontaneously developed pointing gestures by two dolphins involved in a symbolic communication training experiments. Six months after beginning a training program where the dolphins learned to associate symbols on an underwater keyboard with locations of objects/rewards in their tank (e.g., food, toys, and tools), the dolphins began 'pointing' to the location where they expected an imminent reward to be found. The authors describe two types of behaviors; pointing and point/monitoring which

included gaze alteration behaviors. The (not explicitly trained) pointing gestures contained the following elements: the dolphin 1) remained still (i.e., stopped swimming) less than 2 m from the object, and 2) aligned both head and body in the direction of the object. The point/monitoring behavior included two additional behaviors: the dolphin 1) turned its head in the direction of the approaching diver while maintaining body alignment toward the object, and 2) altered head alignment between the object and the trainer several times. These behaviors were considered a spontaneous act because 1) the dolphins were not specifically reinforced for engaging in pointing behaviors, 2) were given the food reward regardless of their production of pointing gestures, 3) were never trained to produce pointing gestures, and 4) were not always rewarded with food when engaging in pointing gestures. Additionally, it was observed that the dolphins were more likely to engage in pointing behaviors when the human researcher was more than 2 m away from the object.

In a follow up study, it was found that dolphins did not engage in pointing behaviors in the presence of an object/reward if there were no human observers present. Moreover, when presented with a reward object with attached handles, the dolphins would take these objects to a researcher that was not in the pool, and never engaged in pointing behaviors directed at the object before taking them to the researcher. There are structural and functional analogies between these behaviors, and declarative pointing behaviors described for primate/human species. Similar to the arguments concerning dog 'showing', the dolphin behaviors were considered less likely to simply be attending to the object and the researcher, and more likely to be pointing behavior for the following reasons: firstly, the dolphins appeared to engage in these behaviors in relation to the presence/attentional state of a potential receiver, indicating that there is a communicative element. In addition, there is little evidence that these behaviors indicate the dolphins' attempt to detect or discriminate the object; a dolphin's vision and echolocation system would allow for adequate perception at distances over 2 m, therefore their close approach to the object did not allow them any perceptual benefit. The fact that the dolphin stopped swimming, and did not appear to move its head in the typical sweeping behavior that is normal for a dolphin inspecting an object with echolocation indicate that the pointing-like behaviors were anomalous, unrelated to the normal object search and discrimination behaviors. In summary, the alignment and monitoring behaviors observed here are atypical behaviors for dolphins. The authors suggest that, given their emergence without explicit training, these behaviors may indicate pointing behavior, which may be analogous to a declarative point (like the 'showing behavior' reported for dogs).

A subsequent study (Xitco *et al.*, 2004) investigated in more detail the ability of these same two dolphins to produce pointing behaviors in relation to the attentional states of a potential receiver. A divider was placed in their tank that allowed the dolphin to inspect objects on the opposite side using either vision or echolocation, but did not allow them to swim beyond it. Two jars were placed on the other side of the barrier, and were baited by an experimenter with food; the dolphin was able to see the food in the jars. The researcher then waited for the dolphin to indicate the correct jar by pointing; that is, by aligning head and body toward the jar with the food. Test conditions were altered as

follows; 1) the length of time the trainer took to respond to a dolphins correct choice was increased to the point where they did not respond before the end of the trial, 2) the researcher turned his back on the dolphin after baiting the jar, eventually (after 30 sec) turning around again and giving the dolphin the reward, and 3) the researcher would swim away from the test-site after baiting the jar before eventually (after 30 sec) returning to give the dolphin the reward. The dolphin's behavior was then scored to see how often they produced both pointing (alignment) and monitoring (gaze alteration) behaviors. Results indicated that the dolphins rarely exhibited monitoring behaviors in the conditions where the researchers had their back turned or swam away, and produced more points during the 'face-forward' conditions. It was assumed that the dolphins were aware of the attentional state of the diver relative to these different conditions. The authors suggest that information was not derived from the human researchers' eyes given that they were obscured by the SCUBA mask. They hypothesize that the dolphin could use echolocation to determine the body orientation of the researcher (aided by the presence of the SCUBA tank on the diver's back), and thus determine a state of attention based on this condition. The dolphins were also more likely to leave the test site in the 'swim-away' and 'back-turned' conditions than the 'face-forward' condition. The results here clearly indicate sensitivity to the attentional states of a receiver on the part of the dolphin, and a change in pointing/monitoring behaviors in concert with this sensitivity. There have also been observational reports of dolphins engaging in what might be pointing behavior in the wild. Dudzinski *et al.* (2003), reported the behavior of wild Indo-Pacific bottlenose dolphins (*Tursiops aduncus*) toward a dead conspecific on two separate occasions. On some occasions, the dolphins involved appeared to align head and body toward the carcass in a similar manner to that described by Xitco *et al.* (2001). However, these anomalous alignment behaviors may have been more closely related to detection and discrimination activities for a stationary object, as echolocation activity was commonly reported throughout the incident. No monitoring/gaze altering behaviors were reported.

2.2.5 Summary

Many authors have commented on the surprising results obtained in pointing experiments with dolphins that reveal a unique ability to comprehend, and possibly even produce pointing gestures (Herman *et al.*, 1999; Pack & Herman, 2004; Xitco *et al.*, 2004). These authors hypothesized that this ability may come naturally to a dolphin, given their (potential) sensitivity to the body orientation of conspecifics while producing a forward-directed echolocation beam. Furthermore, the echoic eavesdropping hypothesis may explain a sensitivity to forward body orientation in combination with an awareness of the attentional states of conspecifics as it relates to perception through echolocation; something that could be related to joint attention. A model of these potential relationships will be provided in section 2.3. A review of the form, function and potential cognitive underpinnings of joint attention and referential pointing has been outlined here. It has been shown that there is limited consensus in the literature as to the presence/absence of underlying cognitive components of these behaviors, as well as complications as to when observed behaviors can be constituted as joint attention or referential pointing. Furthermore, the definitions for the terminology used by different authors are often conflicting. Because of these problems, experimental results have provided controversial

evidence of joint attention and referential pointing behaviors in animals. Despite recent advances in neuroanatomical studies revealing the potential neural substrates of these behaviors, many authors have questioned the ability of behavioral experiments to produce results that reveal anything about the unobservable cognitive underpinnings of joint attention and referential pointing. A breakdown of the behaviors and cognitive mechanisms that have been discussed here, together with evidence for their existence in apes, dolphins and other species is provided in Table 2.2.

Table 2.2 Summary of the evidence for joint attention related abilities in animals

Cognitive mechanism or observed behavior	Evidence for presence in apes?	Evidence for presence in dolphins?	Evidence for presence in other species?
eye detection mechanism	strong	strong	strong
eye detection (neural substrates)	strong	strong	strong
awareness of others' attentional states	strong	strong	strong
intention detection (from behaviors)	strong	strong	controversial
intention detection (from mental states)	weak	weak	weak
intention detection (neural substrates)	not tested	not tested	Strong
gaze following	strong	strong	strong
gaze following around barriers	strong	not tested	strong for corvids
gaze monitoring	strong	anecdotal	weak
simple triadic attention	strong	strong	strong
joint attention	controversial	controversial	controversial
attribute 'seeing' to other agent	controversial	controversial	weak
mental state attribution	controversial	controversial	weak
understanding of others' knowledge/beliefs	weak	controversial	weak
full blown Theory of Mind	none	none	none
intentional communication	controversial	not tested	weak
attention getting behaviors	strong	not tested	weak
pointing comprehension	controversial	strong	strong for dogs
imperative point production	strong	controversial	weak/controversial
declarative point production	controversial	controversial	weak/controversial

2.3 Echoic eavesdropping cognitive model

2.3.1 Introduction

Much debate has taken place concerning the causes of the equivocal results obtained in experiments testing for joint attention and related behaviors in animal species. Despite both theoretical and methodological concerns, three important claims concerning the experimental results with dolphins

have emerged:

- Dolphins comprehend (without training and on initial trials) the referential nature of the human pointing gesture
- Dolphins comprehend (without training and on initial trials) the referential nature of the human gaze cue
- Dolphins spontaneously produce pointing-like gestures

Although these facts have been established for individual dolphins that had been exposed to human behavior throughout their lives (thus, 'encultured' to some extent), there is compelling evidence to believe that, with the exception of dogs, no other animal species yet tested (encultured or otherwise) is capable of a similar level of comprehension on initial tests. However, unlike dogs, dolphins are not domestic animals; they have not been selectively bred to be sensitive to the behavior and communicative cues of human beings. It is therefore necessary to provide an account as to why dolphins are capable of understanding gaze cues, as well as able to understand and produce pointing gestures. As stated earlier, echoic eavesdropping has been cited as a potential behavior/mechanism that has allowed the dolphin brain to evolve the ability to comprehend the basic communicative properties of directional attentional cues. This proposal, as has been discussed in the greatest detail by Pack and Herman (Pack & Herman, 2004; Pack & Herman, 2006; Pack & Herman, 2007), will be outlined here. I will then provide my own model for understanding the relationship between echoic eavesdropping and joint attention/referential pointing (based on points raised in this review) in section 2.3.2.

According to Pack and Herman (Pack & Herman, 2004; Pack & Herman, 2006; Pack & Herman, 2007), the fact that dolphins could use static gaze cues just as easily as dynamic cues reveals that it is not likely the motion of the turning head or pointing arm that cued a dolphin to the correct direction of the object during the object-choice tests. The fact that the dolphins were able to use static cues spontaneously (i.e., on initial trials), rules out the possibility that the dolphins simply learned to associate arbitrary stimuli with the correct position of the object. Additionally, eye cues are used by many species as salient cues leading to attention shifts. But the idea that dolphins use eye cues to orient to the correct object via a reflexive gaze-shift mechanism coupled with an eye detection mechanism has been questioned. The authors note that, in their studies, only eye gaze cue in combination with appropriate head orientation yielded good performance; eye cues alone (i.e., eyes facing the correct object, but head oriented in a forward direction) yielded only chance performance. This is potentially due to two reasons: firstly, dolphins have laterally placed eyes. Therefore, eye cues from a morphologically dissimilar species (e.g., the forward facing eyes of humans) are likely unsuitable cues as forward facing eyes are not normally encountered by dolphin species. Furthermore, as a dolphin turns its head left or right, one of the two laterally placed eyes will always be moving in opposite directions to the head turn; therefore, for the dolphin, there is no analogous structure to the parallel eye orientation cue seen in humans, thus this is unlikely to be a salient cue for a dolphin.

Moreover, the white sclera found in dolphins' eyes is only rarely visible; seen only when a dolphin is frightened or excited. Thus, it is difficult to determine where a dolphin's gaze is directed (for either eye) based on the ratio of sclera to iris. Neither of these cues then is particularly useful for conspecific or interspecific communication in relation to eye gaze, and certainly cannot be driving a reflexive gaze shift mechanism. This may explain why only the direction of the human head was a salient cue for these experiments. Whereas Moore and Corkum (1994) hypothesized that the ability to follow conspecifics' gaze will only evolve in species with primary reliance on the visual modality, forward facing eyes, and a sophisticated social structure, only the social structure factor seems to be relevant for dolphins. For dolphins, the visual modality is roughly equivalent to the auditory (echolocation) modality when it comes to perception (see section 2.1.1). This leads directly to the proposed explanation for the apparent effortless pointing/gaze comprehension by dolphins as proposed by Pack and Herman (Pack & Herman, 2004; Pack & Herman, 2006; Pack & Herman, 2007); the idea that dolphins perceive head orientation as a cue to another agent's attentional state due to echolocation, not vision.

A dolphin's directional (narrow) echolocation click stream is emitted through the melon in a forward projecting beam. As audition is one of the primary (if not THE primary) sense for dolphin species, it would be common for dolphins to observe a conspecific's head/body orientation facing the direction of an object that is the focus of attention (echolocation) for that dolphin. Pack and Herman's (Pack & Herman, 2004; Pack & Herman, 2006; Pack & Herman, 2007) proposal can be summarized as follows: if an eavesdropping dolphin can sense (eavesdrop on) another dolphin who is echolocating in a specific direction on a specific object, this eavesdropping dolphin may 'understand' that the other dolphin is attending to a specific object. Given that dolphins also have a demonstrated capacity for echoic eavesdropping, this may also induce a state of "joint attention to the echoes reflecting off the object" (Pack & Herman, 2004, p. 168). The authors suggest that the directionality of the echolocation beam may in fact 'point' to the object being investigated, although this may occur unintentionally on the part of the echolocating dolphin. This would explain why dolphins could have sensitivity to the attentional states of other agents in relation to the forward-facing direction (either conspecifics or humans). Other authors have similarly proposed that dolphins are able to understand attention of other agents because of the directional structure of the echolocation beam (Harley *et al.*, 1995; Herman *et al.*, 1993; Xitco *et al.*, 2001). The combination of joint attention involving echoic eavesdropping, and an understanding of the attentional state of other dolphins in relation to head orientation may "provide a general foundation for the dolphin's spontaneous understanding of the referent of human point and gaze" (Pack & Herman, 2004, p. 168). An ability to monitor the direction of attention (echolocation beam) of another dolphin has an adaptive value; it may provide a clue to the location of a potential food source for the observing dolphin. The authors suggest that, due to the highly social nature of dolphins species, and the oft observed high-level of group coordination for some species (e.g., cooperative feeding), evolution may have favored the selection of joint attention (through eavesdropping) skills. They cite the example of dolphin's sensitivity to the attentional states of human researchers (e.g., Xitco *et al.*, 2001) as an example of dolphins' predisposition for directing and

monitoring the attentional states of other agents. As stated previously, this proposal does not necessarily indicate that dolphins attribute mental states to other agents, simply that they are aware of attentional states. This proposal combines many of the elements that have been discussed up to this point, but a more detailed look at the potential relationships between these components is necessary. The following section (2.3.2) clarifies these relationships.

2.3.2 Bimodal joint attention

Expanding on the ideas proposed by Herman (1999), and Pack and Herman (Pack & Herman, 2004; Pack & Herman, 2006; Pack & Herman, 2007) and relying on the discussion of joint attention by Xitco *et al.* (2001), a new model of echoic eavesdropping and its relationship to joint attention in dolphins will be discussed here; 'bimodal joint attention'. Bimodal joint attention is hypothesized to include a set of behaviors exhibited by wild dolphins in relation to conspecific social behavior, and comprises all of the behaviors hypothesized to be involved in echoic eavesdropping. If we are to appeal to these behaviors and potential underlying cognitive mechanisms as the basis for dolphins' skill in using human attention/gaze/pointing cues in experimental conditions, we must first describe what these mechanisms are, and how they differ from those mechanisms traditionally understood to be involved in joint attention for humans and primates. To this end, a review of the cognitive mechanisms and behavioral outcomes that are traditionally associated with joint attention will be provided, with emphasis on their relationship to dolphins and this new model.

2.3.2.1 Eye Detection Mechanism

Uniquely for this model of bimodal joint attention, no eye detection mechanism need be posited. Although dolphins evolved from land based animals where an eye detection mechanism was likely to be present, there is little reason to suspect that such a mechanism exists or is needed by extant dolphin species. There are a variety of evolutionary reasons for this, including: 1) for dolphins, conspecific eye cues do not provide clues as to the focus of attention due to laterally placed eyes (a dolphin may be focused on two separate visual-fields simultaneously), 2) vision may not be the primary sense for dolphins (there are even a few dolphin species that may be fully or partially blind, for example, *Platanista gangetica* (Herald *et al.*, 1969)), 3) dolphins may spend considerable time foraging/socializing in low light levels or complete darkness, making eye cues difficult to discern, 4) the unique sleep physiology of dolphins (unihemispheric slow-wave sleep) means that, at any given moment, either eye may be coupled to a 'sleeping' hemisphere, thus a poor cue for attention, and 5) the morphology of the dolphin eye (e.g., rarely visible sclera) render it a poor cue vis-à-vis direction of attention. Evidence from studies with captive dolphins reveals that they do not respond to human eye cues in object-choice tasks (Pack & Herman, 2004). While it may be possible that dolphins have either retained or evolved a neural mechanism that is sensitive to eye cues, it is neither likely nor necessary for this model, as other cues form the basis of dolphins' sensitivity to attentional states. This is in stark contrast to the vast majority of joint attention models provided for humans, primates and other terrestrial animals. For Baron-Cohen's model, the EDD is an essential underlying component (together with the ID) of the shared attention mechanism (SAM). Much of his theory of mindreading

(Theory of Mind) abilities in humans is based on the sensitivity of the human brain to the eyes of conspecifics. It is this ‘language of the eyes’ that is ‘special’ for his model – a fundamental process that may drive the mindreading system (Baron-Cohen, 1995). And, there is evidence that certain cells in the primate brain are indeed sensitive to eye stimuli (Emery, 2000). But for any model of joint attention, it is important to keep in mind that it is sensitivity to *attentional states* that is the core, not necessarily sensitivity to gaze or eye cues.

Eyes may indeed provide cues for the direction of attention of an agent for many animals, but there are other species, like dolphins, for which this sensitivity is unlikely if not entirely needless, thus other attentional cues may be at play. Due to the importance of eye cues for humans, human researchers may have (historically) placed too much emphasis on the importance of eye cues in a joint attention scenario as examined under experimental conditions for non-primate species. Dolphins, however, provide us with an important lesson: despite their lack of response altogether to human eye gaze cues, their use of head and pointing cues is exceptional. This fact then craves a different explanation, and requires us to shift focus away from the eyes, and toward other attentional cues that are clearly salient to dolphins.

2.3.2.2 Attentional States Sensitivity

For the bimodal joint attention model, sensitivity to attentional states is a fundamental mechanism. This is, however, accomplished by cues unrelated to eye gaze. As has been emphasized, a dolphin’s primary state of attention is likely achieved through audition and not vision, either through active echolocation or the reception of passive acoustic cues. For dolphin species, the structure of the echolocation/passive listening receiving beam reveal that ‘auditory attention’ is associated with reception of sound waves through a dolphin’s lower jaw, and encompasses (for ‘best’ reception) a narrow (10°) field extending in a forward direction relative to the dolphin’s head (Au, 1993). A similarly shaped projection beam is achieved during click emissions associated with echolocation; clicks are projected forward and slightly upward of the melon in a narrow (10°) beam (Au, 1993). Thus for dolphins, (like primates), primary focus of attention is in a forward direction, which is due to audition and not vision. Importantly, this reception/transmission beam can not be manipulated without changing direction of the head itself; therefore, for auditory attention, the direction of a dolphin’s head is *always* a visual indication of its focus of ‘best’ (auditory) attention. This is in contrast to primate species where eye direction and head direction can often be independent. Given the primacy that audition has in a dolphin’s perceptual world, direction of auditory attention as revealed through the forward directional cues of the dolphin head, constitutes a conspicuous cue as to a dolphin’s attentional state. When compared to ‘subtle’ eye cues, the saliency of the ‘forward direction head cue’ is, presumably, much greater in terms of being a discernible stimulus for three reasons; 1) dolphin heads are physically larger than dolphin eyes (providing a greater chance of being perceived than much smaller eye-like stimuli), 2) dolphin heads consist of highly prominent morphological features that could indicate direction (e.g., a prominent rostrum), and 3) dolphin heads are 3-dimensional objects and therefore responsive to both echolocation and vision in providing directional cues (unlike

the subtle 2-dimensional directional cues of eyes). Emery (2000) has pointed out that, for prosimians and monkeys, prominent facial features (facial protrusions) may be useful indicators of (visual) attention. Facial cues are more prominent for these animals than for flatter-faced great ape species (including humans). As has been discussed earlier, for many species, morphological features other than eyes may be extremely reliable indicators of focus of attention; tails, head crests, and horns may all act as directional cues of attention for species (Bertrand, 1969; Emery, 2000; Hinde & Rowell, 1961; Zahavi, 1997). The shape of the dolphin head itself then is the primary cue used by conspecifics as to the focus of attention; a highly prominent and highly reliable cue when compared to dolphin (or primate) eyes. Even when light levels are low, and the head of a conspecific may not be visible, it may still be perceptible via echolocation.

Moreover, when compared to primates, the range of motion of the dolphin head in relation to the body is quite limited; consequently, a dolphin's head is often in alignment with the rest of the body (Buchholtze, 2001). Therefore, the entire body in concert with the head may be a reliable cue as to a dolphin's focus of (auditory) attention. This 'horizontal body cue' is not limited to application with conspecifics; many other species (both predator and prey) have similar/identical body morphology to that of dolphins, for example, sharks, fish, etc. In the case of sharks and fish (animals that do not echolocate) the orientation of the body in the horizontal plane is an indication not necessarily of the direction of attention, but of the direction of travel. Most species of fish and nearly all predatory shark species travel in the same direction as their forward facing body alignment. Unlike many terrestrial animals, dolphins, sharks and fish are unlikely (for some species incapable) of orienting their body in one direction (forward) while traveling in another direction (e.g., sideways, up and down, or backwards). In either a pursuit or avoidance scenario, the ability to learn/associate the forward facing directional cues derived from body morphology of these species with their direction of travel constitutes a distinct evolutionary advantage. These examples suggest that, unlike eye cues, the forward facing head/body cues of conspecifics and other species are likely to be extremely useful cues as to the direction of attention (and travel) for dolphins. This does not, however, provide evidence that these cues are in fact used by dolphins in any way; dolphins may have no sensitivity to these cues whatsoever. The experiments described by Pack and Herman (Pack & Herman, 2004; Pack & Herman, 2006; Pack & Herman, 2007) do not provide direct evidence/tests of this sensitivity, nor is there currently any evidence from observational research that provides conclusive proof of such sensitivity. More accurately, the factors listed above and the experimental results *suggest* two things; first, if we posit a cognitive mechanism for dolphins that is sensitive to attentional states, the 'head direction' cue is a much more salient cue than eye direction. Second, if we ignore the possibility that such a mechanism exists, and instead appeal to 'learned associations' of attentional cues for clues as to focus of attention, head cues may provide more robust stimuli than eye cues as to direction of attention. In either case, the strength of the 'forward direction head cue' stimulus is likely to be an effective indicator of focus of attention for dolphin species. As an example, in Xitco *et al.*'s (2001) study, the dolphin stopped swimming in front of the target object and aligned its head and body with the target. This is a body position that is quite similar to a foraging position in a scenario where a dolphin is

inspecting the sea bed with echolocation in pursuit of buried/hidden prey species (Herzing, 2004). If a conspecific has natural (or has learned) sensitivity to this full body alignment cue (a cue that is perceptible through both vision and echolocation), it would be a significant/reliable cue as to the presence of food.

For the bimodal joint attention model itself, sensitivity to ‘forward direction’ head cues and ‘horizontal alignment’ body cues can be posited. This is likely for two reasons: 1) dolphins primary sensory mode (audition) is focused in a narrow forward projected beam, and 2) forward facing horizontal body alignment is a reliable cue for direction of travel for conspecifics, as well as most prey and predator species. This sensitivity, which I will term *alignment cue sensitivity* (ACS), forms the basic ‘low level’ mechanism that drives the bimodal joint attention model, replacing the eye detection mechanism that is commonly seen for traditional/primate models.

2.3.2.3 Intention Detection

For the bimodal joint attention model, intentionality detection (ID) will have a form and function equivalent to that described in Baron-Cohen’s model (Baron-Cohen, 1995). Although there has been debate concerning the levels and kinds of intentionality that lead to joint attention, the kinds of evidence described in section 2.2.3.3 point to a robust, and possibly widespread intention detection mechanism for many animal species. This mechanism is likely an understanding of ‘intention in action’ - the ability to interpret certain self-propelled movements and behaviors as themselves having basic goals (e.g., want to swim in that direction, wants to get the fish, etc). This mechanism (the ID) is likely intimately linked to the ACS for dolphins; associating another agent’s forward facing state of attention with a low-level desire to *do* something (e.g., act on an object, swim in a specific direction) produces the fundamental framework on which later levels of bimodal joint attention rely.

2.3.2.4 Gaze Following and Reflexive Gaze Shifts

For the many studies involving humans and primates, the ability to reflexively follow the direction of gaze (from eye cues) develops early in life. For dolphins, sensitivity to eye cues is likely an irrelevant factor. There is no evidence that dolphins engage in gaze following or reflexive gaze shift behaviors from experimental studies. However, dolphins are able to use head orientation and pointing cues as reliable indicators of direction of attention. There is, however, little evidence to suggest that this is an ‘automatic’ process (i.e., reflexive). However, for dolphins involved in an echoic eavesdropping scenario, an analogous head alignment following ability (possibly reflexive) may be posited; this will be outlined in the following section.

2.3.2.5 Model of Bimodal Joint Attention

For any model of joint attention, the addition of an ‘object’ into the relationship is what separates a simple state of simultaneous-orientation from a state of triadic attention (joint attention). As outlined earlier, joint attention itself is often described as being achieved in relation to a number of potential behavioral and cognitive mechanisms; mental state attribution, gaze monitoring, gaze alteration,

referential pointing, intentional communication, etc. There is no consensus as to which of these factors is necessary for a state of 'joint attention' to have been reached. For this model of bimodal joint attention, I will define a state of joint attention as equivalent to the previously described state of 'shared triadic attention' (STA); similar to the definition of joint attention in use by Emery (2000). For this model, bimodal joint attention consists of a scenario where 1) a dolphin is able to understand that another agent's focus of attention is directed at an object (as discernable through body morphology and behavior; not necessarily unobservable mental states), and 2) a dolphin is able to understand that another agent has intentions (i.e., basic desires) in relation to that object (as discernable through observable behaviors and not necessarily unobservable mental states). There is good reason to believe that a state of bimodal joint attention is easily achievable for dolphin species (much more so than for primate species), and that the ability to achieve this state has allowed dolphins to perform exceptionally well in experimental test of their ability to understand referential pointing on object-choice tasks. The reasons for this stem from a combination of the low level mechanisms (ACS and ID) with (presumably) echoic eavesdropping abilities. In a bimodal joint attention scenario for dolphins involving echolocation (assumed to be normal behavior for wild dolphins) the following chain of behaviors are hypothesized to occur:

- Two dolphins are swimming near each other, oriented in the same general direction
- One of the dolphins initiates a bout of echolocation directed at an object of interest
- The echoes originating from the object are received by both dolphins
- The eavesdropping dolphin orients head position so that her focus of attention is on the object

The result here will be that both dolphins are attending to the same object through audition – with either one or both dolphins eventually actively echolocating on the object. It is likely that both dolphins will also (under some conditions) be able to monitor the object *and* each other using vision. What mechanisms drive the listening dolphin to orient toward the object and are these necessarily relevant to joint attention? There are three possible stimuli (available to the listening dolphin) involved in this chain of events: the emission of echolocation by the echolocating dolphin, the reception of click echoes by both dolphins, and the observable body orientation of the echolocating dolphin. Any combination of these available stimuli may act as cues to the listening dolphin as to the presence of an object of interest. These cues and their combinations are listed below:

- The head/body orientation alone
- The head/body orientation together with the emission of echolocation signals
- The head/body orientation together with the emission of echolocation and the reception of echoes
- The head/body orientation together with the reception of echoes
- The reception of echoes alone

With the exception of the echo cues alone as the only cue that the listening dolphin uses to orient toward the object, all of the other cues (and combinations thereof) fulfill the criteria for the establishment of a joint attention scenario: the listening dolphin uses the attentional cues of the echolocating dolphin to establish a triadic relationship with the object. Attentional cues as displayed by the echolocating dolphin then come in two forms across two modalities: head/body orientation, echolocation emission and echolocation reception. At first it might appear odd to label ‘echolocation emission’ as an attentional cue, as this is foreign to the idea of attention in primates. But for an echolocating species, these cues may in fact be more salient attentional cues than eye gaze (for primates) or head/body orientation. For eye gaze cues, an imaginary ‘line of sight’ needs to be posited for an agent attending to an object based on the (visually) observable orientation of the eyes. The same is true for head/body orientation cues. But for echolocation emission, the ‘line of sight’ of the echolocation beam is not imaginary – it is a detectable stimulus available to a listening dolphin. It is possible that by listening to the emissions alone, a listening dolphin can determine the direction of focus of the beam as emitted by an echolocating dolphin. The shape and direction of the beam is determined by the propagation of various frequencies within the outgoing echolocation click emissions; it is conceivable then that a listening dolphin positioned at various points along the transmitted beam will have access to sufficient acoustic information to ‘reconstruct’ or otherwise determine the shape and direction of the echolocation beam. If this ability is combined with the head/body cues when observed in concert with vision, an even more reliable cue as to the focus of attention (line of sight) can be established. This then constitutes the ‘bimodal’ aspect to the term *bimodal joint attention*. But direct perception of the transmitted echolocation beam constitutes half of this proposed mechanism for sensitivity to echolocation. The second component, which, when combined with the first, makes these cues even stronger, is the direct influence of the proven ability of dolphins to eavesdrop on object information as received from another dolphin’s echolocation. In a bimodal joint attention scenario, object information as revealed through echolocation click echoes is directly available to an eavesdropping dolphin. Thus, unlike visual joint attention in primates, the listening dolphin can actively monitor the status of the echolocating dolphin’s attention states (through both vision and audition), AND could have intimate perceptual knowledge of the exact object on which the echolocating dolphin’s attention is focused. For an eavesdropping dolphin, this object information need not be inferred from attentional cues alone, but is directly perceptible through the ability to receive object information via the click echoes generated by the other dolphins.

These combination of cues are likely more salient than the visual cues alone, suggesting that dolphins may have a keen awareness of attentional states of other dolphins (across two modalities), leading to effortless achievement of states of bimodal joint attention. Bimodal joint attention is then comprised of an ACS mechanism, an ID mechanism, and *echolocation cue sensitivity* (ECS) consisting of information in two forms; *transmitted echolocation beam perception* (TEBP) and *echoic eavesdropping perception* (EEP). For TEBP, there is one further important potential property that should be mentioned. Aside from the possible perception of the direction of the beam itself, the production of an outgoing click may be a cue that a listening dolphin can either learn to use, or that

may reflexively trigger a search for the source of the click production. This may, in some way, function like a reflexive gaze shift to the presence of eye cues; upon hearing an outgoing click, a listening dolphin may first initiate a search for its source (the echolocating dolphin), subsequently using the ACS cues it finds to initiate a state of bimodal joint attention.

This hypothetical scenario of bimodal joint attention does not, however, reveal to what extent the proximate mechanisms leading to joint attention are derived from learned associations, or in-built cognitive mechanisms. As discussed earlier, an ACS mechanism may either result from an evolutionary sensitivity to attentional cues, or develop as learned associations throughout a dolphin's life. The same may be true of the ECS. If one were to find reflexive shifts in orientation in relation to the presence of either head/body cues or echolocation cues (similar to reflexive gaze shifts in primates), this would be evidence for a possible in-built cognitive responsiveness to these cues; currently, this has not been tested experimentally. With this in mind, it does not seem possible to infer something akin to 'reflexive attention shifts' as a behavior fundamental to a model of bimodal joint attention. Furthermore, this model of bimodal joint attention does not lead directly to any of the following concepts/behaviors/mechanisms often discussed in conjunction with joint attention: mental state attribution, intentional communication, and Theory of Mind. As has been seen, bimodal joint attention, akin to STA in primates, requires only that the dolphin have sensitivity to attentional states, and not mental content. Although it is possible that bimodal joint attention may lead to, or possibly even relies on mental state attribution, this model does not require this ability in order to function. There is, as has been discussed in section 2.2.3.2, good reason to believe that experiments concerning joint attention in non-human animals are unlikely to reveal the extent to which mental state attribution is at work. Furthermore, discussions of Theory of Mind (comprising the ability to reason about one's own or other's beliefs) are not a necessary extension of this model, nor are they required by it. Although belief attribution has been studied in dolphins (Tschudin, 2006), this concept is peripheral to a discussion of bimodal joint attention.

It is important to point out that, in a bimodal joint attention scenario, there is no need to posit that any of the behaviors involved consists of intentional communication insofar as they intend to manipulate the attentional (or mental) states of other agents. Echoic eavesdropping, resulting in bimodal joint attention requires only an *awareness* of another agent's attentional state (i.e., in which direction the object of interest can be found), and does not necessarily arise because either dolphin intends to manipulate the attentional state of another vis-à-vis the object. Although this is an important component of pointing and point production (as will be discussed in section 2.3.2.7), the bimodal joint attention model does not require acts of intentional communication in order to function. The same is true for the idea of referential communication; in a bimodal joint attention scenario, the idea that either the projected echolocation beam or concomitant head/body position is a referential act is not necessarily correct. A referential act (like intentional communication) must be produced with the specific intent to manipulate the attentional state of a potential receiver. For bimodal joint attention to be attained, an echolocating dolphin may appreciate that another agent is also attending to the same

object, but may not necessarily be intending to 'refer' that agent to the object. Again, this might indeed be the case for pointing behaviors observed in dolphins, but it is not an essential component or consequence of the bimodal joint attention model.

The bimodal joint attention model then consists of three low level sensitivities: ACS, ECS and the ID. With the introduction of an object as the focus of attention of for a dolphin, a second dolphin, appealing to each of these three sensitivities, will attain a state of STA (shared triadic attention) with the first dolphin, which will be equivalent to a state of joint attention for this model. No further mechanisms need be introduced in order for this state to have been achieved (e.g., mental state attribution, Theory of Mind, attention getting behaviors, monitoring, etc.) Unlike traditional models, the bimodal joint attention model does not require active monitoring on the part of an observer dolphin; the focus of attention of the first dolphin is directly perceptible due to the EEP mechanism. Because ACS and ECS sensitivities are encoding attentional information in their own right, when combined/summed, the result is a robust sensitivity to the attentional states of conspecifics with reference to an object that is the focus of that dolphin's attention (during an echolocation event). The two mechanisms found in the ACS, body orientation sensitivity and head orientation sensitivity, are depicted in Figure 2.3.1 and Figure 2.3.2 respectively. The two mechanisms found in the ECS, transmitted echolocation beam perception (TEBP) and echoic eavesdropping perception (EEP), are depicted in Figure 2.3.3 and Figure 2.3.4 respectively. The bimodal joint attention model hierarchy itself is depicted in Figure 2.3.5.

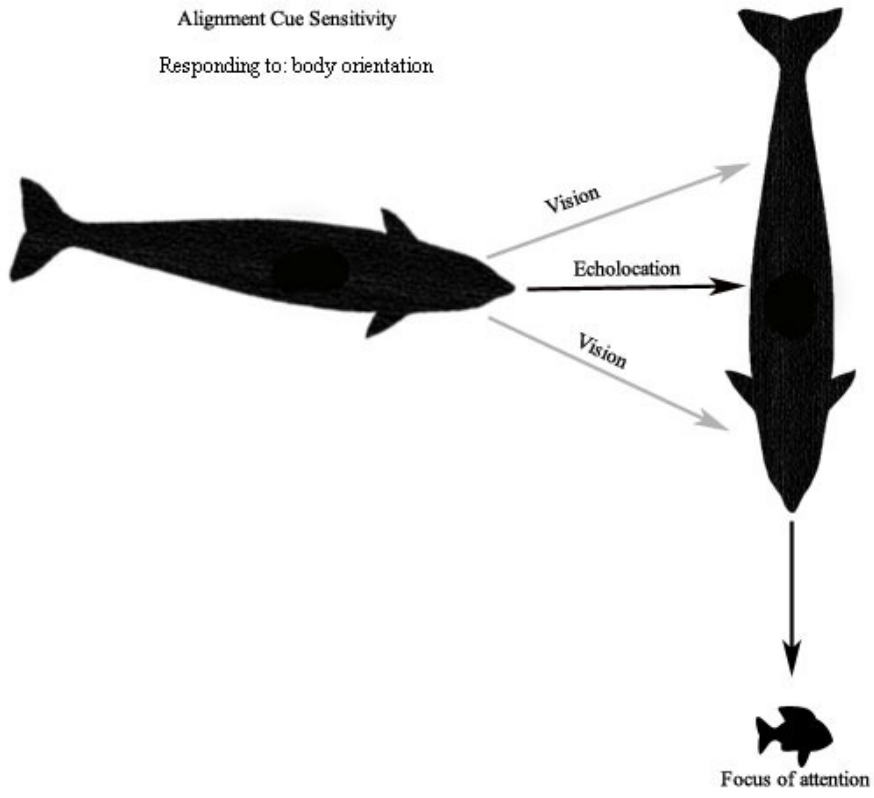

Figure 2.3.1 Alignment Cue Sensitivity (ACS) – body orientation

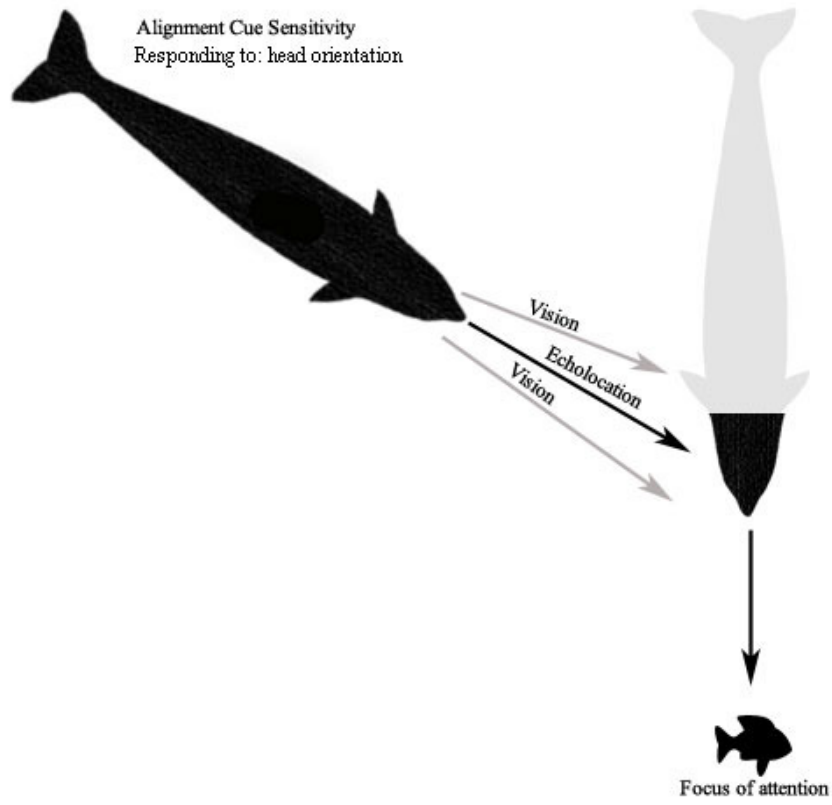

Figure 2.3.2 Alignment Cue Sensitivity (ACS) – head orientation

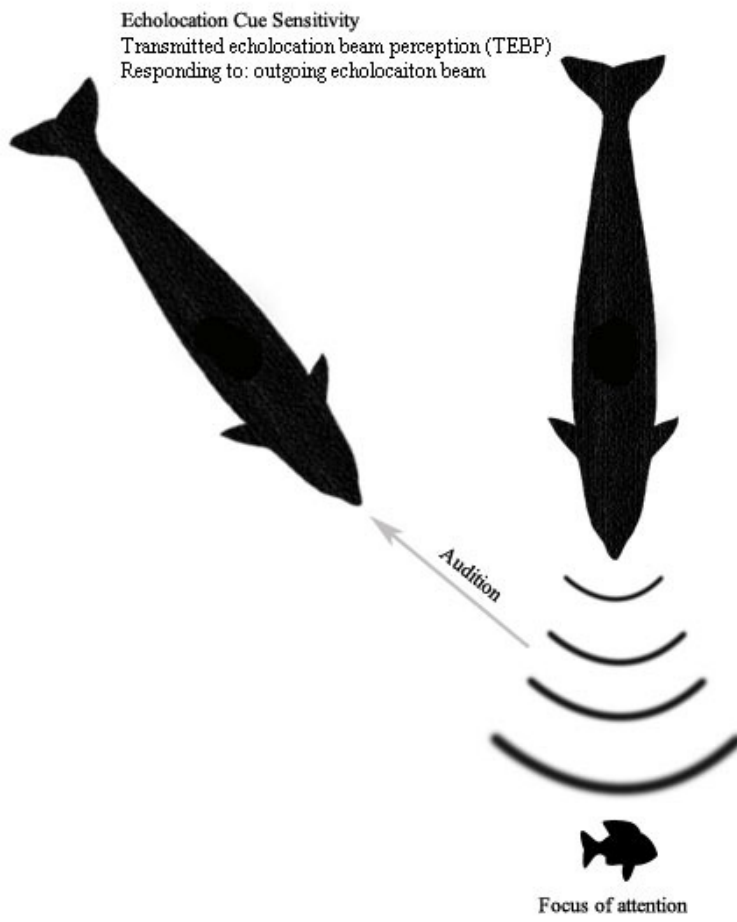

Figure 2.3.3 Echolocation Cue Sensitivity (ECS) – transmitted echolocation beam perception (TEBP)



Figure 2.3.4 Echolocation Cue Sensitivity (ECS) – echoic eavesdropping perception (EEP)

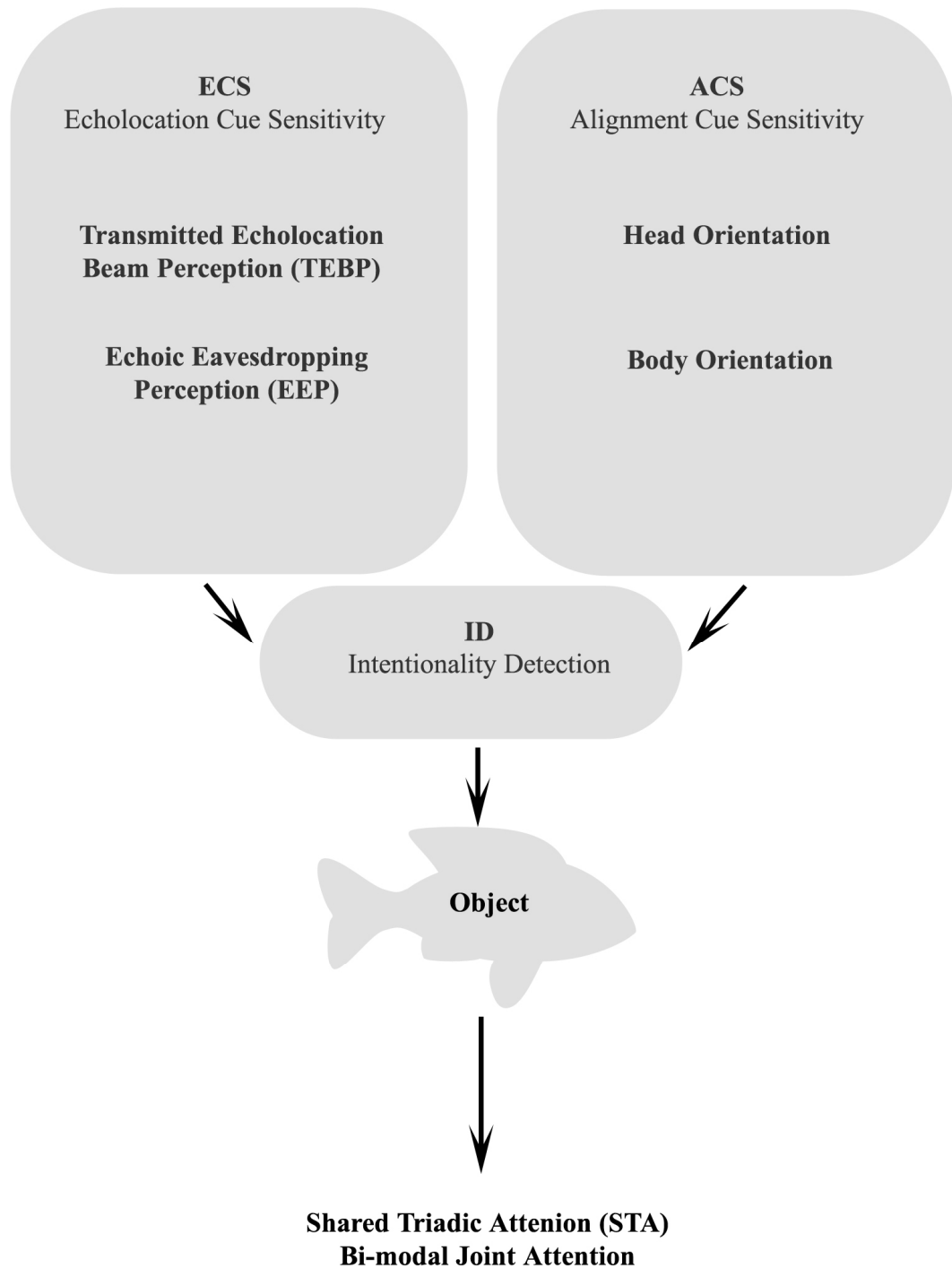

Figure 2.3.5 Bimodal joint attention model

2.3.2.6 Gaze Monitoring

Gaze monitoring, as has been defined in relation to humans and primates (i.e., altering gaze between object and agent), is not a fundamental component of a bimodal joint attention scenario as I describe it here. A dolphin's 'gaze' can be defined as the visual field encoded by either eye, or the forward orientation field associated with active echolocation and passive listening. A dolphin would have limited need to 'monitor' (turn head back and forth) a conspecific in the same manner as primates, as

it could monitor an object with either one eye (or echolocation) while simultaneously monitoring the position of a conspecific with the other eye. In addition, a dolphin can ‘monitor’ the attentional state of another dolphin resulting from echolocating emission through passive audition alone. Thus, for this model, gaze monitoring (in the primate sense) is an irrelevant behavior. However, some authors have pointed out that ‘gaze monitoring’ behaviors have been observed for captive dolphin species in relation to a possible joint attention scenario involving humans. For Xitco *et al.*’s (2001) discussion of dolphin ‘pointing’, a dolphin was observed aligning its head and body in the direction of a food reward, while alternating head position to monitor the location of a researcher/diver; described as a ‘point/monitor event’. These monitoring events were more likely to occur when the human researchers were more than 2 m away.

This manner of monitoring behavior is not predicted by the bimodal joint attention model. Alternate explanations need to then be posited. A description of the echolocation activity of the dolphins involved in this experiment was absent, so it is not possible to discuss the relationship between the pointing/monitoring behavior and echolocation. This monitoring behavior is likely intimately linked with pointing behavior; the origins of which do have links with bimodal joint attention (see section 2.3.2.7), but are unlikely to be a fundamental component of ‘natural’ joint attention for dolphins. One possible explanation is that the dolphin engaged in a form of joint attention mediated by the experimental conditions in which it was operating, having learned to use pointing cues in relation to the attentional states of the diver. This novel behavior may have involved monitoring behaviors whereby the dolphin oriented both eyes toward the diver as a means of tracking the diver’s movement toward the food reward. By utilizing both eyes in concert, resulting in biscopic vision, 3D direction of movement cues (e.g., whether or not the diver was approaching the food reward) would have been available. In the video clip associated with Xitco *et al.*’s (2001) article, the dolphin’s head is raised slightly upward when facing the diver, a position that facilitates biscopic vision for dolphins, as witnessed by their use of ‘upside down’ tracking of prey species (e.g. flying fish). In their discussion, the authors point out that the dolphin might have monitored the diver to check if they were responding to the point gesture toward the food; a response they might have initiated having learned that humans responded to similar dolphin-initiated behavior in relationship to food rewards during different tasks in the past. The authors discuss other examples of the monitoring behaviors taking place and being modified depending on the attentional states of the human diver, lending support to the idea that these were true monitoring behaviors. Though the question remains as to whether or not the dolphin could have tracked movement with just one eye while maintaining head alignment with the reward, and if so, why it did not do this. Xitco *et al.* suggest that although this behavior may be novel, it might in fact be ‘natural’ insofar as bimodal joint attention is concerned.

Perhaps the dynamics of bimodal joint attention, whereby dolphins are keenly aware of the attentional states of other dolphins due to the presence of echolocation, coupled with the rarity with which they need to ‘request’ a conspecific to act upon an object, results in (latent) monitoring behaviors being suppressed. It may be that in the presence of humans (a non-echolocating agent that is nonetheless

analogous to a conspecific), these latent monitoring behaviors emerge spontaneously. It is possible that these pointing and monitoring behaviors were executed in combination with echolocation cues as an ‘attention getting’ behavior. Unfortunately, a full discussion of the exact nature of the monitoring behaviors in relation to positional information and echolocation usage was not provided, making these speculative arguments difficult to prove given the evidence from this experiment. In any event, gaze monitoring behaviors are not a necessary component of the bimodal joint attention model.

2.3.2.7 Pointing and Gaze Experiments Explained

With an understanding of the cognitive mechanisms that comprise the bimodal joint attention model (i.e., ACS, ID and ECS), and those that do not (e.g., mental state attribution, intentional communication, gaze monitoring), an attempt can be made to explain the results of dolphin pointing/gazing experiments (both point/gaze comprehension and point production) in relation to this model. The important questions that can now be addressed are *what* cue did the dolphins respond to, and *why* did they respond to it. Although suggestions as to both *what* and *why* have been offered (e.g., Herman *et al.*, 1999; Pack & Herman, 2006; Pack & Herman, 2007; Xitco *et al.*, 2001), a discussion with focus on the potential underlying cognitive mechanisms will help to flesh out these ideas. These ideas, as summarized by Pack and Herman (2006, p. 285), are as follows: “Attending to another’s distal interrogation of an object through echolocation is a natural behavior that may generalize to other types of functionally similar distal referencing. Thus, a dolphin echolocating on an object may in effect “point” with its echoic emission and correlated body orientation to that object, although not necessarily with the intention of informing another. Nonetheless, if a dolphin receiver identifies an object being interrogated echoically by a nearby dolphin informant, the animals may be engaging in an act of joint attention. Consequently, joint attention to the reflections from an ensonified object whose originating ensonifier can be identified may provide the basis from which the dolphin’s spontaneous understanding of human-directed pointing and gazing emerges.” The important point outlined in this passage, that will allow a discussion of what and why, is the idea that a capacity for bimodal joint attention allows a dolphin to generalize to functionally similar situations (e.g. human point/gaze comprehension). This suggestion will be further discussed.

First, the question of what cue dolphins respond to for point/gaze comprehension tasks is presented. For Tschudin *et al.*’s (2001) experiment, six captive dolphins were tested for spontaneous comprehension of a pointing gesture. The dolphins were not previously trained to respond to the human pointing gesture, although they all had extensive training for show performance. The gesture(s) consisted of the extension of the arm and finger in the direction of the object. Two objects were placed laterally in relation to the dolphin; the distance to the object was likely between 0.2 m and 1.2 m (Pack & Herman, 2006). For objects on the researcher’s right side, this resulted in a ‘direct point’, whereas objects on the left consisted of a ‘cross body point’. The points were dynamic insofar as they were initiated in the dolphin’s presence. Additionally, the point was held until the dolphin made a response. Three of the six dolphins tested in this experiment performed above chance on this task for their initial 12 trials. These experiments also tested the ability of the six dolphins to use gaze cues. For gaze, the

researcher oriented the head (and eyes) in the direction of the target object while the body (and arms) remained stationary. For the gaze trials, two of the six dolphins performed significantly above chance on the initial 12 trials.

As discussed in section 2.2.4.6, Herman *et al.*'s studies of pointing and gaze comprehension in dolphins (Herman *et al.*, 1993; Herman *et al.*, 1999) utilized a variety of point-forms. The two dolphins used in the Herman studies (Akeakamai and Phoenix), were involved in long term studies of artificial language comprehension and cognition experiments. Both dolphins had exposure to human symbolic gestures (including pointing) either formally or informally. Pointing gestures had, however, not been explicitly trained or tested before the 1993 experiment. For this test, a dynamic full arm and finger extension point (held for 2 or 3 sec) was used to indicate upon which object the dolphin was required to perform an action. These initial trials produced responses greater than what would be expected by chance. For Herman *et al.*'s (1999) experiment, pointing gestures were incorporated into a string of commands that required the dolphins to perform an action on one of three possible objects present in the dolphins' pool. Objects were placed >2 m from the dolphin and the researcher (thus classified as 'distal'). The dynamic pointing gestures (extension of arm and finger) were brief (around 1 sec), and were immediately followed by a command gesture. The dynamic pointing gestures came in three forms: ipsilateral point (extended finger and arm from same side of body as object location), exaggerated point (including movement of the body in the direction of the point), and cross-body points. Both dolphins performed above chance on initial trials involving all three points, except for those trials where the target objects were placed behind the dolphin – for these trials, only Phoenix performed above chance. For the first experiment in Pack and Herman's (2004) study, cross body and ipsilateral points were again used to indicate the correct object, but the pointing gesture was only given after first having given first the action command. Like the previous study (Herman *et al.*, 1999), high (errorless) performance results were obtained for both dolphins. In a follow-up experiment, potentially confounding head and body (torso) cues were controlled for by placing the researcher behind a white opaque Plexiglas board. The pointing cues were given by having the researcher's arm extend from behind the board, or 'reach around' the board (in the case of the cross body point) to indicate the target object.

In an additional experiment, the 'dynamic' component of the point was removed; the dolphins were exposed to the pointing cues only after an opaque brown plywood board (that was previously 'hiding' the researcher) was removed, revealing the researcher in a static pointing position. After having controlled for both inadvertent torso/head cues, and after having removed the dynamic aspect to the pointing gesture, both dolphins performed without error on almost all trials for each condition. For the same study, similar experimental designs were used to test for the dolphins' ability to comprehend gaze cues. Like pointing, gaze cues were produced dynamically in full view of the dolphin, and from behind an opaque board that was obscuring the researcher's torso and arms. Static gaze cues were presented after removing an opaque barrier. Like the pointing results, the dolphin's responses were highly significant in all conditions. An additional experiment tested the dolphins' ability to use eye

movement cues alone; the dolphins were presented with either a cue where the researcher's eyes were obscured (with opaque goggles) but their head gaze turned toward the target object, or where the eyes were visible and shifted toward the target object while the head remained stationary. For eye movement cues, both dolphins' performance was significantly below their level of performance for previous gaze and point cues (close to chance levels). Performance for head cues given with opaque goggles were significantly better than chance.

Following these experiments, the cues that dolphins appear to respond to are as follows: pointing with the arm and finger (both static and dynamic) extended in the direction of the target object regardless of the position of the body, and head points (both static and dynamic) facing the target object regardless of the position of the body. This comprises the *what* in the question 'what cues do dolphin respond to', so we now need to address *why*. Pack and Herman (2006) suggest that the dolphins have learned to generalize the skills that they naturally possess due to their capacity for bimodal joint attention, and apply them to a novel but analogous situation involving human pointing/gaze. What then is the exact nature of this generalization in relation to the model of bimodal joint attention, and in what ways must a dolphin be applying what it *knows* vis-à-vis what it has *learned*? Concerning gaze, as has been discussed, eye cues are not utilized by dolphins in object choice tasks. Instead, human head direction is used as a cue. What is the nature then of this directional cue? In its simplest form (as described in Pack & Herman, 2004), a static human head facing the target object (in 'terminal position'), disassociated from torso and arm cues, was used by the dolphin as a reliable cue for the correct object. Devoid of movement and eye cues, this form must then consist of features derived from human head morphology, for example the nose, chin, cheeks, etc. If we appeal to the dolphin's ability to derive attentional state cues from these alignment features (as acquired through the ACS), then we must also posit that dolphins have learned something about the nature of human anatomy and how this relates to dolphin morphology. For a dolphin to follow human static gaze, the dolphin must know that a human's focus of attention is not equivalent to the direction that the top of a human's head is pointing. A simple anatomical analogy would be likely to conclude such a thing. Given that dolphins' auditory focus of attention is projected linearly in the forward facing direction extending from the melon, the 'natural' sensitivity would likely lead them to construe that a human's attention is also projected from the top of the head (analogous to the melon) in line with a human's horizontal (in the water) or vertical (when standing) body position. If this were the case, then head cues as described in the above experiment would not be of use to the dolphin. Clearly, if the dolphin is sensitive to a human's attentional state, then they have learned to correlate the facial cues of a human with their direction of attention. It has been shown that dolphins are able to mimic the movements of human researchers, including the movement of analogous body parts (e.g., tail for feet, pectoral fins for arms), and appear to associate the human head with the dolphin head for such tasks (Herman, 2006b). Given these findings, it does not seem unreasonable that a dolphin should be able to shift the expected direction of attention to the forward-facing features of the human head as opposed to the top of the head; dolphins appear capable of relating their own body plan to that of humans. For those dolphins exposed to training by human researchers over the course of many years, sensitivity to a human's

attentional state in relation to the directional cues of human facial morphology could easily be leaned. Herman (2006a, p. 453) summarized this suggestion as follows: “That the dolphin also understands the referring function of gaze as directed by human head movements may signal that it has developed a profound appreciation for human attentional signals in general.” The presence of the ACS in combination with a dolphin’s proven ability to generalize analogous body parts for humans, help explain how this suggestion relates to the bimodal joint attention model.

The results of pointing experiments are, unfortunately, less easily explained. If the ACS mechanism governs a dolphin’s ability to derive attentional cues from the head position of a human researcher, does this same mechanism then govern the understanding that a point is also an alignment cue equivalent to a head cue? If this is the case, then a dolphin could be receiving conflicting alignment/attentional cues during object choice tasks. In experimental conditions where a researcher’s head is facing forward, but the arm is extended toward the object, a dolphin is being presented with two ‘attentional’ cues, both appealing to the ACS. In such conditions, the dolphin responds to the point cue and not the head cue. Why is this the case? It could be concluded that, if the point cue is an alignment/attentional state cue, then it is more salient than the head cue - perhaps because the head cue is more subtle in terms of occupying visual space. It is possible that a dolphin is somehow placing attentional cues along a hierarchy of saliency, and relies on a cue which satisfies most strongly the requirements of an ACS; that is, which cue most closely resembles a ‘forward facing (dolphin) head cue’. It may be the case that a dolphin forms an analogy between the form of the pointing gesture, and the form of the dolphin head/rostrum and/or form of the dolphin body. Perhaps the visual shape and appearance of the human point activates the ACS mechanism, and because the extended arm/finger cue is visually ‘larger’ than the researcher’s head cue, the point cue overrides the head cue. Unfortunately, no experiments have been reported that specifically address the saliency of such cues. Concerning these problem, the following questions arise:

- When presented with a head gaze cue and a conflicting point cue, which cue will the dolphin use?
- When presented with two point cues of varying form (e.g. ipsilateral vs. cross-body), which point form will take precedence in an object choice task?
- When presented with two point cues of varying ‘strength’ (e.g., just a hand and finger vs. fully extended arm), which point form will take precedence in an object choice task?
- When presented with a static forward-facing head cue, can the dolphin use this in an object choice task?
- What cues other than the head direction and gaze result in good performance (e.g., torso, legs, top of head, lips)?

Furthermore, it is also possible that the dolphin has learned which cues a trainer would prefer that a dolphin respond to in a scenario where multiple cues are presented, leading to a learned hierarchy of

cue preference. For the dolphins involved in the object choice tasks, commands have been issued to the dolphins primarily through hand gestures throughout its training. This fact may influence a dolphin's preference for the point cue as opposed to the head gaze cue in scenarios where both are present; that is, hand/pointing cues, by virtue of the training regime, always assume primacy.

It might not, however, be the case that a dolphin responds to a pointing gesture as an analogue to a head gaze attentional cue. For the case of humans and primates, the pointing gesture itself is not understood to be a cue to an attentional state that is equivalent to a gaze cue; rather, for humans, pointing is a discrete act, separate from gaze and other attentional state cues. If this is the case for dolphins, then an ACS mechanism is not a likely source. If we conclude that, for dolphins, the human pointing gesture is NOT triggering an ACS mechanism (as discussed above), then the human point must be appealing to a separate mechanism, or to another learned process. Herman (2006a, p. 453) suggested that “the dolphin may understand pointing because it possesses an acoustic analogue of pointing in its natural world, through its highly focused echolocation beam.” This suggests not that the dolphin understands a point as an analogy to the attentional state of a human as derived through body morphology, but that the dolphin has understood the point as an analogy to the echolocation beam itself. The equivalent mechanism from the bimodal joint attention model that one could appeal to as responsible for a response of this nature is the TEBP: transmitted echolocation beam perception. The TEBP mechanism allows a dolphin to infer the direction of the attentional state of another dolphin based upon the perception of that dolphin's echolocation transmission beam. It is possible to posit that the dolphins involved in the object choice tasks appealed to this mechanism when first faced with the problem of how to use the human pointing gesture; that is, they reflexively and automatically understood that the human point was analogous to an echolocation transmission beam. For this analogy to have taken place, the dolphins from the object choice trials would have to have understood/accomplished the following:

- Divorce the beam/arm point analogous structure from the forward-facing head morphology from which an echolocation beam is normally perceived
- Realize that the beam/arm point analogous structure can indicate a direction separate from head direction
- Realize that the point perceived in the visual modality is equivalent to an acoustic beam perceived in the auditory modality
- Realize that the solid two dimensional visual percept of the pointing arms is equivalent to a dynamic 3D echolocation beam
- Understand that the point does not produce echo returns or anything equivalent to echoes

There are a number of problems with this kind of analogy. It is difficult to know if the structure of the 3D echolocation beam is perceived by the dolphin as an analogue to a solid 2D ‘beam’ like structure as would be discerned through vision. Cross-modal recognition experiments have shown that

properties of objects as perceived through echolocation (i.e., through the returning echoes) are functionally equivalent to those properties observed through vision (Harley *et al.*, 1996; Herman & Pack, 1992). But it is not known to what extent the outgoing clicks themselves produce a percept that is functionally equivalent to anything that is perceived in vision. It is important to separate the two mechanisms that produce a dolphin's sensitivity to echolocation cues (ECS): TEBP, and echoic eavesdropping perception (EEP). For this analogy, it is TEBP that is hypothesized to be involved and not EEP. The human pointing gesture obviously does not create anything equivalent to click echoes that the dolphins in these tests could use to determine which of the target objects was the 'focus' of the point. Without the ability to receive object information through the returning click echoes, a dolphin must be relying on only half of the cognitive mechanisms that lead to ECS. Furthermore, the human pointing gesture is a referential act; that is, a behavior that is produced specifically to manipulate the behavior/attentional states of other agents, whereas an echolocation beam (insofar as the bimodal joint attention model is concerned) is not necessarily (or possibly even ever) produced specifically to manipulate the behavior/attentional states of other agents. If the dolphins were able to draw such an analogy, all of these specific problems must have been overcome. Importantly, all of these problems must have been overcome on initial trials upon first exposure to the pointing gesture.

I have presented two mechanisms that may be responsible for a dolphin's spontaneous comprehension of the pointing gesture: the ACS (producing an analogy between the point gesture and a human's head alignment/attentional state), and TEBP (producing an analogy between the point gesture and an echolocation beam). These two mechanisms are individual components that are part of the overall framework producing a dolphin's ability for bimodal joint attention. It is a capacity for bimodal joint attention in a general sense that Pack and Herman (2006) appeal to when they state that "joint attention to the reflections from an ensonified object whose originating ensonifier can be identified may provide the basis from which the dolphin's spontaneous understanding of human-directed pointing and gazing emerges." However, EEP or sensitivity to echo reflections can not be a factor that directly yields spontaneous comprehension of pointing gestures as an echolocation analogue to a pointing gesture that entirely devoid of echo reflections. Perhaps this suggestion could be taken to mean that, due to a predisposition for bimodal joint attention in a general sense (consisting of EEP in combination with TEBP, ACS and ID), dolphins are (more so than primate species) sensitive to joint attention-like scenarios. That is, perhaps no single mechanism is responsible for the dolphins' responses in these tests, rather a combination of cognitive mechanisms related to bimodal joint attention are at work. I would further suggest that the underlying mechanisms present in bimodal joint attention are in and of themselves not sufficient to explain the dolphins' apparent spontaneous comprehension of pointing, although they may explain their comprehension of gaze. Despite the fact that a human point has structures in common with both the human gaze and an echolocation transmission beam, a series of inconsistencies in form must be addressed if either analogy is to develop; something unlikely to occur on initial trials.

I would suggest that it is a combination of the mechanisms involved in bimodal joint attention

working in concert with what a dolphin has learned about human anatomy, human behavior, and test conditions that yields success on initial trials with the human pointing gesture. The ability to learn the significance of the pointing cue is then the crucial missing link in this explanation. To illustrate this point, consider what is required of a dolphin in the object choice tasks. The experimental conditions consist of two sets of instructions: 1) a dolphin is being requested to perform an action on a specific object that is not yet been indicated. That a dolphin responds at all to this kind of request is because of long-term exposure to a training regime in which dolphins learn to interpret symbols and signals provided by researchers/trainers. In this case, symbols and signals that represent actions. 2) a dolphin is being given a signal that indicates which object. There are two types of signals that could be used to indicate this; the first is a symbolic signal or symbol. A symbol consists of an arbitrary abstract gesture (or vocal signal) that stands in for the object itself. The second is a referential signal. This kind of signal is NOT a symbol that stands in for the object, rather, it is a behavior/signal that refers (indicates to) the dolphin where the object is located. The human pointing gesture is a referential signal and not a symbol. In an object choice task, it is clear that a dolphin does not use the pointing gesture as a symbol. Instead, a dolphin needing to determine which object it needs to perform an action on in order to comply with the trainer's/researcher's request must await a signal that will provide them with a cue as to the object, more specifically, a cue to the direction in which the object can be found. Thus, a dolphin participating in an object choice trial is expecting a cue to a direction so that it can complete the task at hand. It will then appeal to any cue available to it that might be a reliable indicator of direction. When appealing to directional cues, the link between direction and attention is clearly quite strong (as predicted by the bimodal joint attention model) – thus, a dolphin's sensitivity to the attentional state of the trainer would explain why gaze cues would be used as reliable indicators of the direction in which an object could be found. But point cues may not be strong indicators of the researcher's focus of attention in and of themselves, as has been discussed. Furthermore, a point cue may be an analogy to an echolocation beam, but this is a tenuous analogy, with only a few links to a bimodal joint attention model, therefore unlikely to be a strong cue.

It is more likely that the dolphin has learned a very simple rule; that the pointing cue is a class of signals that indicates the direction in which the target object can be found. In a more general sense, it might be true that dolphins are better able to learn to use signals that are related to direction and attention because of their likely sensitivity to a variety of cues across two modalities that are known indicators of the direction in which an object can be found. In a natural setting, a dolphin may readily learn that another dolphin's head direction, body direction and echolocation beam direction are all reliable indicators as to their focus of attention. If the dolphin is also able to learn that the object they perceive via echoic eavesdropping is also the same object that is the focus of attention of the other dolphin, then these cues will be even stronger. Thus, bimodal joint attention has primed dolphins to search for signals that are salient cues as to the direction in which an object can be found, allowing them to extrapolate what they already know from bimodal joint attention and the attentional states of other agents in relation to objects, to the object choice task. But, importantly, this explanation requires that the dolphin learns that a point cue is in fact a reliable cue as to the appropriate direction. In the

absence of informal or formal exposure to the human point form, this cue will likely not be of use to a dolphin. This explanation helps to clarify why only half of the six dolphins participating in the Tschudin *et al.* (2001) study were able to use the point cue – that is, the dolphins performing at chance level simply had not yet learned that a point cue could be used as a cue for direction, whereas the other dolphins had. If there were a robust cognitive mechanisms at work (like ACS or EEP), then comprehension of the point gesture should have been automatic for all six dolphins. It is likely that the dolphins involved in the Pack and Herman studies had, at some point, learned that a human point is a directional cue. Any inadvertent or informal use of a point or a point-like cue in combination with other cues such as motion toward an object, or gaze toward an object during the dolphin's training regime as an indication as to which object a trainer was indicating could have allowed the dolphin to lump the pointing signal in with these other classes of directional indicators. This learned lumping of directional cues is readily explained by the bimodal joint attention model wherein a series of closely and distally related conspecific cues across two modalities all reliably indicate object direction. For novel human cues, dolphins, with their proven propensity for symbol, signal and behavioral learning, may have generalized an ability to extract directional cues in a bimodal joint attention to the object choice task; a task where they were already expecting some form of cue indicating which object. It is an open question as to whether or not a strictly controlled training regime wherein a dolphin was never exposed to anything related to point like gestures would yield successful results on initial trials for that dolphin's first exposure to the human point. This kind of training might be all but impossible. That dolphins are able to easily learn to understand pointing gestures is remarkable – when compared to primates, dolphins clearly demonstrate an ability to follow a variety of pointing and attention cues in object choice tasks. This might indeed be related to their “profound appreciation for human attentional signals in general”, and may be triggered by the many mechanisms involved in bimodal joint attention in combination with a discrete ability to apply what they have learned about the world across multiple domains.

One final consideration deserves mention. Can a dolphin understand that attentional states come in multiple forms? That is, could a dolphin appreciate that another dolphin may be attending to separate objects simultaneously, possible across two modalities? Given that echolocation and vision are equivalent insofar as cross-modal cognition studies have revealed, a dolphin may understand the notion of ‘attention’ in fundamentally different ways to that of primates. Despite the fact that primates (like all animals) are capable of using stimuli presented across various modalities (e.g., smell, vision, touch, etc) to form a percept of the world, and that cross-modal transfer is a common property of this percept, scientist often define ‘attention’ almost exclusively in relation to vision. Thus, for primates, attentional cues are equivalent to those cues that indicate focus of visual attention. A discussion of a primate's focus of ‘tactile’ attention does not seem equivalent to vision either in terms of cue saliency or strength of percept. But for dolphin species, echolocation and vision are much more closely aligned; both may be determined by the observation of directional attention cues (e.g., direction of head) and may both yield functionally equivalent percepts. Thus they may both be equally as strong or ‘equivalent’. Although the bimodal joint attention model does not require an eye detection mechanism,

it may none the less be within a dolphin's ability to learn that conspecifics may be capable of attending to an object using vision, despite the potential shortcomings of this particular cue. If this is the case, it may be possible that a dolphin can appreciate that a conspecific is attending to an object using echolocation as derived from cues available to ACS, TEBP and EEP, while simultaneously attending to a *different object* using vision by means of one or both of its laterally placed eyes. If this is possible, (i.e., if a dolphin contains a separate and parallel set of sensitivities to the visual attentional cues of conspecifics) then a model of bimodal joint attention should not understand 'attention' as a singular concept. For the current model of bimodal joint attention, sensitivity to eye cues has not been posited, and so this idea will not be considered in detail. It is worth mentioning however, that if dolphins have strong sensitivity to eye cues, in addition to those cues involved in bimodal joint attention, then a novel explanation for point comprehension is plausible. A dolphin may understand that a human researcher is displaying two sets of directional/attentional cues simultaneously; the cues related to vision (as observable through forward facing head cues – something that the dolphin would need to learn is equivalent to vision), and attentional cues as provided by the pointing arm/hand. This state of plural attention would not then be understood as 'foreign' to the dolphin. The trouble is (again) explaining why the dolphin would choose one set of attentional cues over the other in an object choice task.

Point comprehension and the bimodal joint attention model require only that a dolphin understands an attentional state of another agent in relation to an object. When an animal engages in intentionally communicative acts (like producing referential communication) in relation to that object, that animal is not only aware of another agent's attentional state, but aware that that attentional state is subject to manipulation based on one's own behavior. According to some authors, this constitutes an additional (and rather more complex) set of representations and further cognitive mechanisms. The presence of this type of understanding can be inferred if and when an animal was to engage in (declarative) pointing behaviors. There are no reports of wild dolphin engaging in declarative pointing (or analogous) behaviors. However, two reports of spontaneously emerged pointing behaviors in captive dolphin produced by Xitco and associates (Xitco *et al.*, 2001; Xitco *et al.*, 2004) suggest that dolphins have a capacity to produce point-like gestures, and that these may be equivalent to declarative points (as discussed in section 2.2.4.6). These accounts also fulfill the four criteria for 'intentional communication'; 1) audience, 2) monitoring, 3) attention getting, and 4) persistence. Audience, monitoring and persistence have been addressed previously. Attention getting (the third criterion of intentional communication) had not been discussed, yet there is some anecdotal evidence for this within the accounts provided by Xitco and associates (Xitco *et al.*, 2001; Xitco *et al.*, 2004). In the video accompanying the 2001 article, the dolphin engaged in the gaze alternation behavior produces an additional behavior that may be construed as an attention getting behavior: a bubble cloud. Bubbles are often considered a form of visual communication for dolphins (Pryor, 1990), and the production of a bubble cloud during the point/monitoring behavior for this observation may in fact have been produced as a means of getting the attention of the researcher/diver. Unfortunately, this suggestion was not discussed by the authors for these accounts.

Concerning point production and declarative pointing/intentional communication, there may be mechanisms within the bimodal joint attention model which may account for some of these behaviors. A bimodal joint attention scenario results in a state of shared triadic attention (STA). Concomitant with such a state are the abilities to attribute intentionality to certain behaviors, and to be aware of other agents' attentional states. These basic properties of a bimodal joint attention scenario provide the cognitive mechanisms from which they may *learn* a relationship between how the behavior of other agents in terms of their attentional states can be manipulated. Dolphins, however, appear to engage in pointing behaviors spontaneously – without having learned or been expressly taught how the production of this class of communicative behaviors will manipulate the behavior of the researchers in relation to the food reward. Thus, although the mechanisms facilitating bimodal joint attention are required for point production, they are not enough on their own to explain why point production occurs spontaneously. In this case, there may be mechanisms present other than those within the bimodal joint attention model that can be appealed to. These additional social cognition mechanisms allow dolphins a natural ability to not only be aware of the attentional states of conspecifics, but to actively manipulate these states. Some authors have suggested that such abilities are derived from the constraints of the complex social societies in which dolphins live (Pack & Herman, 2006). The Machiavellian intelligence hypothesis suggests that species required to navigate a complex social world must evolve mechanisms that allow them to form and maintain complex social bonds, as well as have awareness of third party social bonds, as well as the cognitive toolset that allows for the subtle manipulation of such relationships (Connor & Mann, 2006). Since it has been suggested that dolphins live in societies with such requirements (Connor & Mann, 2006), we may posit that an ability to manipulate the attentional states of other agents through the production of declarative pointing may be a natural behavior, and that this may explain its spontaneous emergence in the Xitco experiments. These abilities are, however, beyond the scope of the bimodal joint attention model, although they may certainly be supported by it.

2.3.2.8 Summary

A cognitive model has been presented here that attempts to describe those mechanisms that may be driving a dolphin's ability to engage in bimodal joint attention in the wild. For humans, joint attention plays an important role in their lives – human social cognition, with its close relationship to language acquisition and Theory of Mind, relies heavily on an ability to share information between individuals, including the ability to engage another's mind in triadic relationships with objects. For non-human primate species, these ecological and social requirements may not be as strong, and, consequently, non-human primates may be less able to be involved in joint attention like scenarios with conspecifics in the wild, or with human researchers in experimental conditions. Although many animals are able to respond to eye and gaze cues, entering into a triadic relationship with an object where both agents are responding to and aware of each other's attentional states is rare, or only occurs after much training. The apparent exception to this rule is the unique case of the dolphin, where the properties of echolocation have led to ecological situations wherein a keen awareness of the attentional states of

conspicuous has been merged with a keen awareness of the object upon which another agent has focused that attention; the result of echoic eavesdropping. These bimodal joint attention scenarios are likely arrived at constantly and effortlessly within the dolphin's natural environment; a fact that helps explain why dolphins, unlike non-human primates, can easily learn to use attentional and other directional cues in relation to objects in joint attention experiments. A breakdown of the mechanisms putatively associated with joint attention in humans, and those mechanisms required by the bimodal joint attention model are provided in Table 2.3.

Table 2.3 Comparison of mechanisms and behaviors involved in joint attention and bimodal joint attention for dolphins

Mechanism/Behavior	Traditional models of joint attention	Bimodal joint attention in dolphins
Eye detection mechanism	Present	Not necessary
Reflexive attention shift	Present	Not necessary
Attentional state sensitivity	Present	Present
Simple Triadic Attention (STA)	Present	Present
Gaze monitoring	Present	Not necessary
Gaze/attention following	Present	Present
Intention detection	Present	Present
Mental state attribution	Sometimes Present	Not necessary
Point production	Sometimes Present	Not necessary
Alignment cue sensitivity	Present	Present
Transmitted echolocation beam perception	Not present	Present
Echoic eavesdropping perception	Not present	Present

In order to determine if wild dolphins engage in behaviors predicted to follow directly from the 'echoic eavesdropping' hypothesis as discussed in this review, and to explore how these behaviors are related to a discussion of joint attention in dolphins, it was necessary to collect relevant data from a wild dolphin species. These data must consist of both video and audio data allowing for the analysis of echolocation production and measurements of dolphins' swim positions relative to each other during activities where a likely echoic eavesdropping scenario presents itself. Therefore, it was necessary to find a group of wild dolphins habituated to the presence of human observers and their recording equipment, and to develop a data collection protocol capable of encoding echolocation and positional information. A description of the subjects, equipment and methods used in this study is provided in Chapter 3.

Chapter 3 Method

3.1 Subjects

In order to test the three hypotheses formulated for this study, two data sets were collected from observations of free-swimming Indo-Pacific bottlenose dolphins. The population observed in this study inhabit the coastal waters of Mikura Island; the 7th island in the Izu Island chain, located approximately 200 km south of Tokyo, Japan at 139°36'E, 33°52'N (Figure 3.1.1). Mikura is a dormant volcano 20.6 km² in area, 16.4 km in circumference and is characterized by steep coastal cliffs and narrow beaches with small to large boulders (Kogi *et al.*, 2004). A resident dolphin population estimated at ~160 individuals is regularly observed. The dolphins are typically seen within ~300 m of the island, and it is believed the waters around the island are the core habitat for this population (Figure 3.1.2). Near-shore depth ranges from 4 to 20 m. Depths of 100 m or more can be found as near as 150 m offshore. The substrate consists primarily of small to large boulders and pebbles, with occasional areas of sand and patches of 'tosaka' (seaweed likely of the genus *Meristotheca*). Systematic observations of this population began in 1994 by the Mikurajima Bandouiruka Kenkyukai (MBK), which is translated as the 'Mikura bottlenose dolphin identification group'. Since 1994, primarily during the summer months, teams of scientists from MBK, the Dolphin Communication Project, Mikurajima Iruka Kyoukai and ICERC Japan conducted video- and photo-identification studies of this population both using underwater and surface observations (e.g., Dudzinski *et al.*, 2003; Kogi *et al.*, 2004; Sakai *et al.*, 2006a; Sakai *et al.*, 2006b). Researchers from various universities in Japan and abroad have participated on specific research projects using this population (Morisaka *et al.*, 2005a; Morisaka *et al.*, 2005b). This species was confirmed as Indo-Pacific bottlenose dolphin (*Tursiops aduncus*) through DNA testing (Wang *et al.*, 1999). From 1994 to 2001, a total of ~ 170 individual dolphins were identified and cataloged (Kogi *et al.*, 2004). Each year ~ 90% of the individual dolphins are re-sighted. Life histories, age class, sex, and other factors are known for the majority of the individuals within this population.

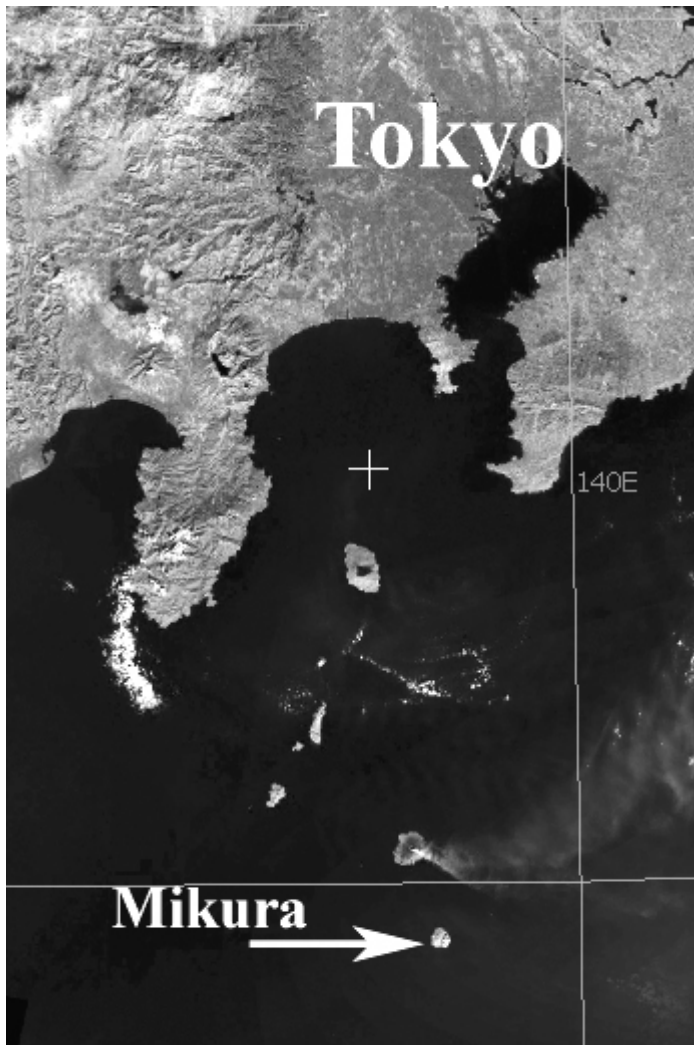

Figure 3.1.1: Location of Mikura-jima (139°36'E, 33°52'N) (image from NASA Landsat – World Wind software)

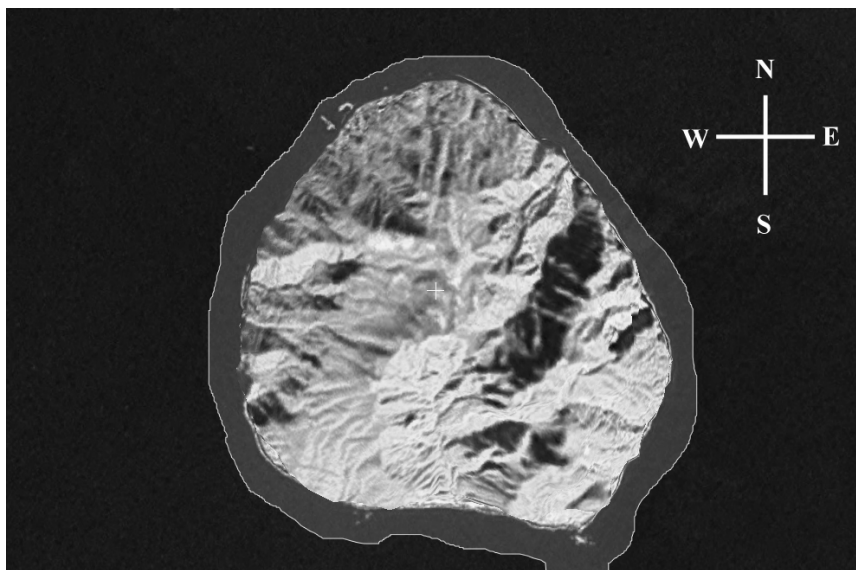

Figure 3.1.2: Mikura island – nearshore area with core habitat of dolphin population shaded gray (image from NASA Landsat – World Wind software)

3.2 Equipment

3.2.1 MVA

The low frequency component of dolphin echolocation signals and their frequency-modulated (FM) sounds below 20 kHz were recorded with a mobile video/acoustic system (MVA) (see Figure 3.2.1 and

Figure 3.2.2) (Dudzinski *et al.*, 1995). The system consists of two omni-directional hydrophones (custom made, with a bandwidth of 400 Hz – 20 kHz and a sensitivity of –3 dB) cabled through a custom underwater housing into the stereo inputs of a Sony PC101 mini-DV video camera. The spacing of the hydrophones on the chassis of the housing is greater than 64 cm; approximately 4.5 times the human inter-aural distance. This exaggerated placement makes it possible for a human reviewer to distinguish ‘left’ and ‘right’ sources during audio playback based on inter-aural time delay/intensity; something not possible with a conventional stereo placement underwater due to the increased speed of sound in water (~1500 m/s depending on temperature, pressure and salinity (Wong & Zhu, 1995) - nearly 4.5 times faster than the speed of sound in air, which is ~331 m/s depending on temperature, humidity and pressure (Cramer, 1993)). Video is recorded on the camera in conjunction with the two channels of audio being supplied by the hydrophones. The camera is controlled using mechanical switches located on the outside of the housing.

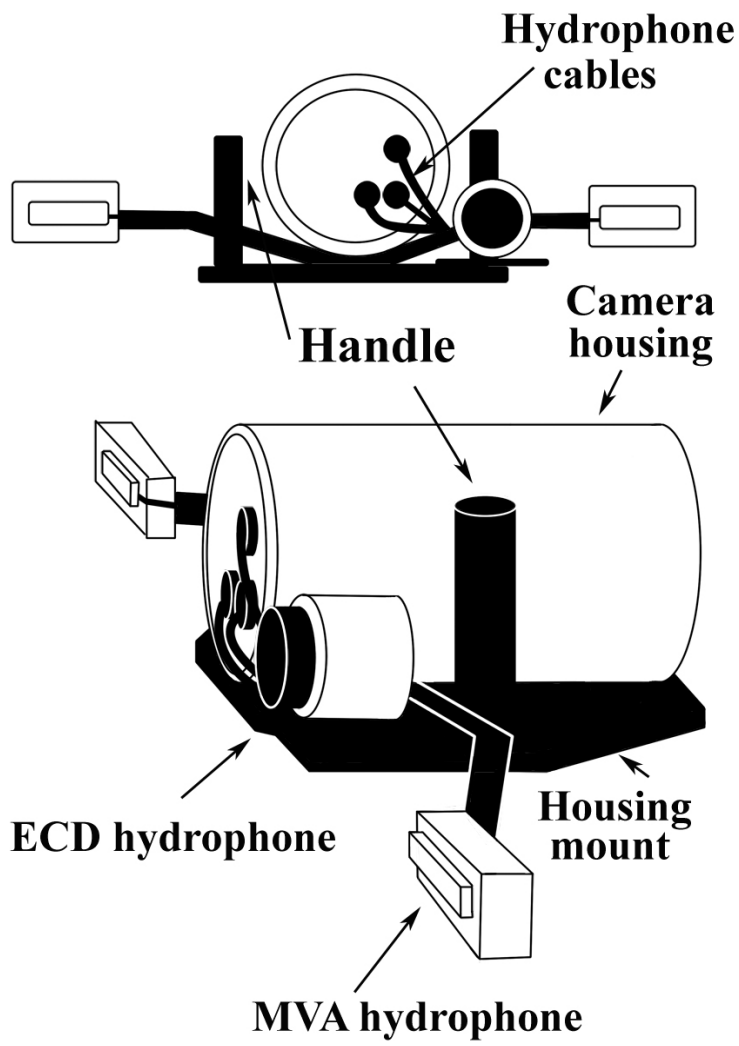

Figure 3.2.1: The MVA4 schematic

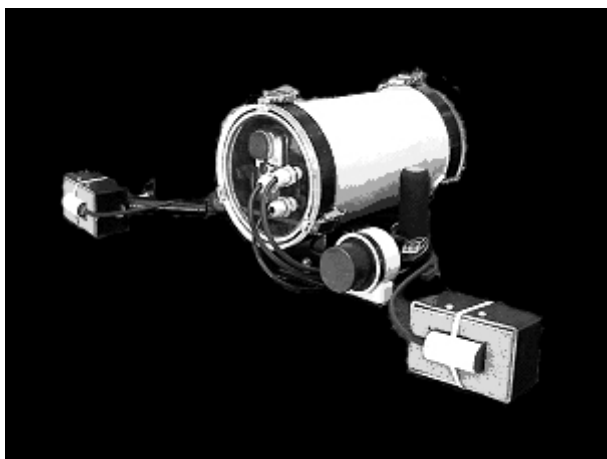

Figure 3.2.2: The MVA4 photograph

3.2.2 ECD

Amplitude-modulated echolocation click sounds above 20 kHz were recorded in two bandwidths with a Sony TCD-D8 digital audio tape (DAT) recording device, receiving signal from a single wide-band hydrophone (3.0 kHz - 150 kHz, sensitivity of -162 dB re 1 uPa to -164 dB re 1 uPa, respectively), connected through 2 ECD circuit boards (Figure 3.2.3). Two band-pass filters with center frequencies at 70 kHz and 120 kHz were applied to the signal from the signal hydrophone via the two ECD boards. Combined receiver sensitivities in each of the bands were -149.5 dB re 1 V/ μ Pa at 70 kHz and -144 dB re 1 V/ μ Pa at 120 kHz. Each of the filters had an approximate 15 kHz band-width allowing relatively good isolation of energy distribution between either of the bands (NewLeap-Ltd., 2000).

The ECD board enables detection of high-frequency dolphin echolocation clicks, and makes them recordable on conventional recording devices by processing the original signal using an envelope detection algorithm (Figure 3.2.4). Through the envelope detection method, the directionality and shape of the original signal, the inter-pulse intervals and the (relative) pulse amplitudes are retained. The digital recorder (DAT) stores real-time information (date & time) in the sub-code of recorded signals so that ECD audio data can be correlated accurately with the video and audio data being recorded on the camera. The use of the ECD device allows the recording of dolphin echolocation signals that might otherwise go undetected using conventional recording equipment (see section 3.3.6).

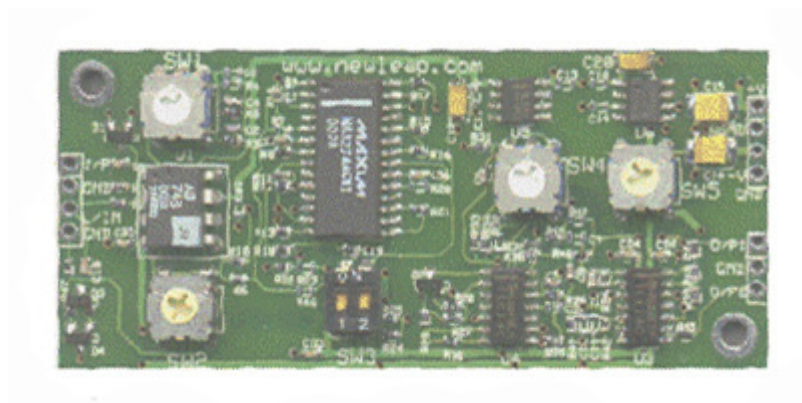
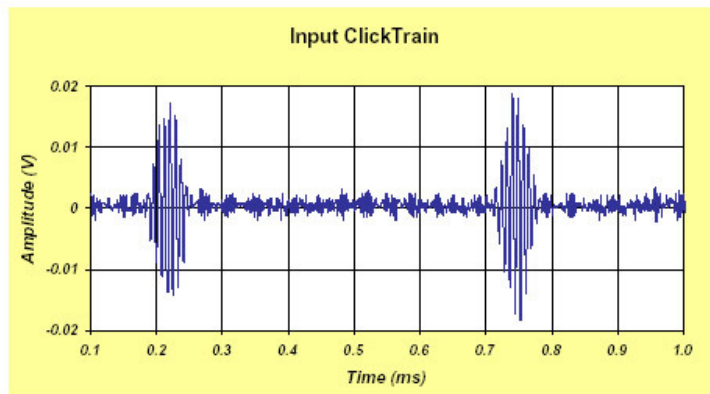
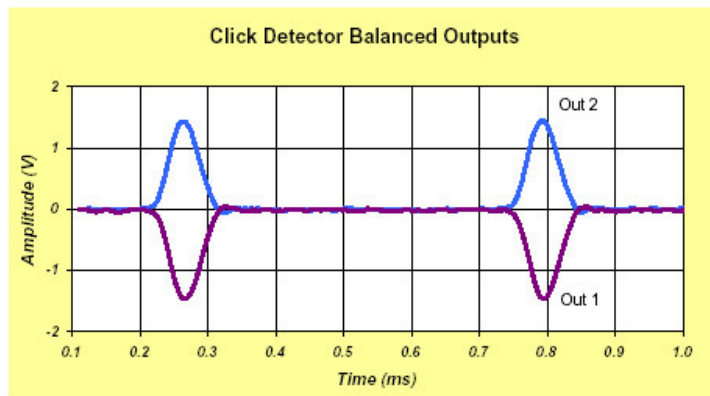

Figure 3.2.3: An ECD circuit board



Plot ECD1



Plot ECD2

Figure 3.2.4: Plot ECD1 shows a typical echolocation ‘click’ (raised cosine) input. Plot ECD2 shows the output corresponding waveform. ©2000 copyright NewLeap Limited, UK.

3.3 Procedure

Data are collected from the Mikura island field site as part of the annual summer research season (~2 months in duration) for the Dolphin Communication Project (DCP). DCP is the organization with which this study was associated for data collection. The goal of DCP’s research on Mikura is to continue a longitudinal study of signal exchange and communication among dolphins. Video and audio data are collected from free-swimming wild dolphins using non-invasive observational techniques (see section 3.3). A comprehensive data set is collected during research trips aboard dolphin-swim tour boats. Mikura dolphin tour boats are ~8 m in length with a half meter draft and typically carry ~8 passengers in addition to the captain. Video and audio data are recorded during water entries (see section 3.3), with additional data collected from the surface. Using *ad libitum* and focal group sampling methods for additional behavioral data, the supplementary data in Table 3.1 were collected for each research trip as part of DCP’s longitudinal study.

Table 3.1: Supplemental data collected during research

Data Variable
Date
Trip #
Boat captain and name of boat
Number of passengers
Start and End time of research trip
Water clarity
Wind speed and direction
Swell height and direction
Beaufort/sea state
Location and time of dolphin sighting from surface
Number of dolphins sighted and size of groups/subgroups
Direction of group movement seen from surface
Broad behavioral context of the group
Time of water entry and exit for each entry
Number of passengers in the water
Number of boats observed for each sighting and entry
Size of groups/subgroups seen during entry
Direction of group movement seen during entry
ID, gender and age of dolphins observed

During the field season, video and sighting logs are maintained; each video tape is analyzed and individual dolphin IDs are recorded for each video sequence using a dolphin ID database maintained by researchers affiliated with DCP and MBK. Initial observations of dolphin behaviors are also noted *ad libitum*, referencing a dolphin ethogram developed by DCP director Kathleen Dudzinski in 1992. This data set is utilized by research associates affiliated with DCP for a variety of ongoing research projects. It is from this comprehensive data set that a subset of data was assembled for this study.

For this study, video and audio data were used from 3 field seasons; 2004, 2005 and 2006. The data sets assembled for this study were extracted from the video and audio data collected from each of these field seasons. A table showing the total data collected for these field seasons can be found in Table 3.2.

Table 3.2 Summary of data collection for each of the three field seasons used in this study

Data Variable	2004	2005	2006
No. of Boat trips	20 trips (from 2 June to 18 July)	31 trips (from 22 May to 22 July 2005)	41 trips (from 11 May to 05 July 2006)
No. of minutes on effort	38 hours, 31 minutes (2,311 min. on the water)	59 hours, 06 minutes (3,546 min. on the water)	76 hours, 35 minutes (4,595 min. on the water)
No. minutes of video	~450 minutes (or 7.5 hrs, recorded on 10 videotapes)	~576 minutes (or 9 hours and 36 minutes, recorded on 13 videotapes)	~736 minutes (or 12 hours and 16 minutes, recorded on 17 videotapes)
No. of sightings	92 (total) range per trip: 1 - 8 (mean = 4.2, median = 4)	108 (total) range per trip: 1 - 8 (mean = 3.5, median = 3)	141 (total) range per trip: 1 - 8 (mean = 3.44, median = 3)
No. of water entries	151 (total) range per trip: 2 - 12 (mean = 7.6, median = 9)	216 (total) range per trip: 2 - 12 (mean = 6.97, median = 7)	266 (total) range per trip: 2 - 13 (mean = 6.49, median = 6)
No. of total dolphins seen for which identity is confirmed	121	103	134

Underwater dolphin behavior data is collected using a continuous individual focal-follow protocol (Altmann, 1974), otherwise termed “focal-animal sampling” (Mann, 1999). After water entry, an individual dolphin is selected for a focal-follow with the MVA and was continuously recorded until the animal was out of view, at which point a new animal was chosen. Choice of focal follow subject is random. This sampling protocol is appropriate for an observational study where it is not possible to record all animals and interactions during an observational session using incident/all-event sampling, scan sampling or other sampling techniques that are difficult if not impossible to apply to dolphin groups (Mann, 1999). All behavioral activity of the individual in the focal follow, including interactions with other individuals, as well as vocalizations, is recorded using the MVA and ECD. This comprehensive set of behavioral data is collected from multiple field sites by DCP, all employing the same collection protocol. This ensures stability and consistency of data across sites and from year to year. It is from this set of video and audio data that the data sets for this study was sampled and coded.



Figure 3.3.1: The MVA4 in use by the author (image from Mio Yanagase)

Video episodes used for analysis in this study are taken from the data sets collected during each of the three field seasons on Mikura from 2004 through 2006. Episodes were transferred to PC for analysis as follows: the video and stereo audio data recorded on mini-DV tapes on the camera were copied to DVD discs using a DVD recorder connected to the camera via the DV-out connection. The DVD is then converted into an AVI file using Super DVD Ripper (720x480 stereo 44.1 kHz audio and 29.97 Hz video using MPEG-4 Video codec V2). This file is then opened in Windows Movie Maker and/or Adobe Premier for review. During analysis of the 2006 data, the DVD was reviewed directly on the PC – event clips were the converted to AVI using FlaskMPEG. Audio from the DAT tapes are transferred to PC via an M-Audio Transit USB external soundcard interface though an optical to USB 2 connection set to transfer at 2IN 2OUT 24 BIT 8000Hz 48000Hz. This audio information is recorded into Sound Forge 6 at 24bit stereo 44.1kHz, and saved as a .wav file. Two data sets have been codified from the raw video and audio data saved in the above file formats on the PC.

3.3.1 Data Set 1: baseline dyad echolocation behavior

The first data set is intended to collect baseline echolocation behaviors for dolphin dyads documented by the camera. Criteria for selecting an episode for analysis was as follows: video and audio are

reviewed in Adobe Premier or Windows Movie Maker until an onscreen scenario appears where only 2 dolphins are in view. If the two dolphins are within approximately 1 dolphin body width and length of each other (~2 m between rostrums), and if both of the dolphins are positioned facing within 90° of the camera (an angle at which echolocation click sounds could be recorded), this clip represents a candidate for inclusion as an episode in Data Set 1. The start of the event occurs when both dolphins are positioned as described above, with no other dolphins in view. The video is then played back from that point and the audio is recorded using Sound Forge 5.0 (Sound Forge 8.0 in 2006). The end of the event occurs when either of the dolphin's head is no longer in view of the camera, or if the dolphin dyad is joined by another dolphin (i.e., a third dolphin comes into view). A visual examination of the recorded audio is then made for the duration of the event; using one-zero sampling methods, the audio data is scored with regards to the number of click trains present during 1 sec intervals, beginning at the start of the event. To determine the number of click trains present, peak-to-peak inter-click-intervals are examined for regularity of occurrence and similarity of relative amplitude levels. This is an effective method of determining the presence of echolocation clicks from 0, 1 or 2 sources. If the visual click data are unclear (due to a high signal-to-noise ratio, possible click overlap, or irregular click interval periods), the episode is discarded. For all click data used in this study, the click trains recorded are considered 'echolocation' click trains, and not social 'burst pulse' trains – the difference between these two types of pulsed sounds are often difficult to distinguish based on repetition rate or other factors (see Herzing, 2004). It is assumed that clicks focused on the camera are likely to be echolocation. Wherever possible, the ECD audio data are examined in Sound Forge. If this audio file can be accurately synched to the echolocation activity for the episode in question, the click data from the ECD audio file is used in lieu of the video audio as the ECD are more likely to detect and record the presence of an echolocation click than the conventional audio (see section 3.3.6). After the appropriate variables have been recorded in SPSS, a video clip of the event is saved as a separate file. The following table (Table 3.3) provides a list of the variables recorded for each of the event clips for Data Set 1.

Table 3.3: Variables for Data Set 1

Variable Name	Variable Description
Event Number	The number of the event/episode
Tape ID	The tape ID number as recorded in the DCP format
Counter Number	Counter Number as displayed by the video playback software at the start of the event
Date on Screen	Date on Screen during event/episode
Screen Time	The screen time as displayed at the start of the event
Total length of episode - dyad swim	The total length of the event
ID of dolphin on the left	The ID number as found in the DCP/MIK dolphin ID database if this can be determined
ID of dolphin on the right	The ID number as found in the DCP/MIK dolphin ID database if this can be determined
D1 age class	The age of the dolphin according to the DCP/MIK dolphin ID database if this can be determined
D2 age class	The age of the dolphin according to the DCP/MIK dolphin ID database if this can be determined
D1 Gender	The sex of the dolphin if known
D2 Gender	The sex of the dolphin if known
MC pair	Is this a mother calf pair – as determined by DCP/MIK dolphin ID database where mother/calf IDs have been confirmed
ECD confirm echolocate	Was it possible to synchronize the ECD .wav file with the video/audio file for the echolocation bout
Number of ECC trains recorded 0-1 second*	The number of simultaneous echolocation click trains recorded during 1 second interval

*The previous variable is repeated at 1 second intervals for 60 seconds

3.3.2 Data Set 2: *echoic eavesdropping behavior*

Video and audio are reviewed in Adobe Premier or Windows Movie Maker until an onscreen scenario appears where 1 dolphin is seen to change (or remain in a position) to face the camera and engages its echolocation. If a second dolphin is anywhere in view at this point, this episode is considered a candidate for Data Set 2. A point in the video is then chosen approximately 3 or 4 sec before the audio from the initial echolocation bout is heard to begin. The video is then played back from that point and the audio is recorded using Sound Forge 5.0 (Sound Forge 8.0 in 2006). The audio file recorded on Sound Forge is then visually examined until the first 'click' in the echolocation click train can be determined. The time of the occurrence of this click is then established, after which the start of the echolocation 'event' can be determined - 1 sec before the first click occurs. The end of the event occurs when either of the dolphins' heads is no longer in view, or if echolocation ceases from both dolphins. A visual examination of the recorded audio is then made for the duration of the event beginning 1 second before the first dolphin (D1) engages its echolocation. Echolocation information (length of click train, time between onset of D1's echolocation and D2's echolocation, etc.) is coded for the event (see Figure 3.3.2).

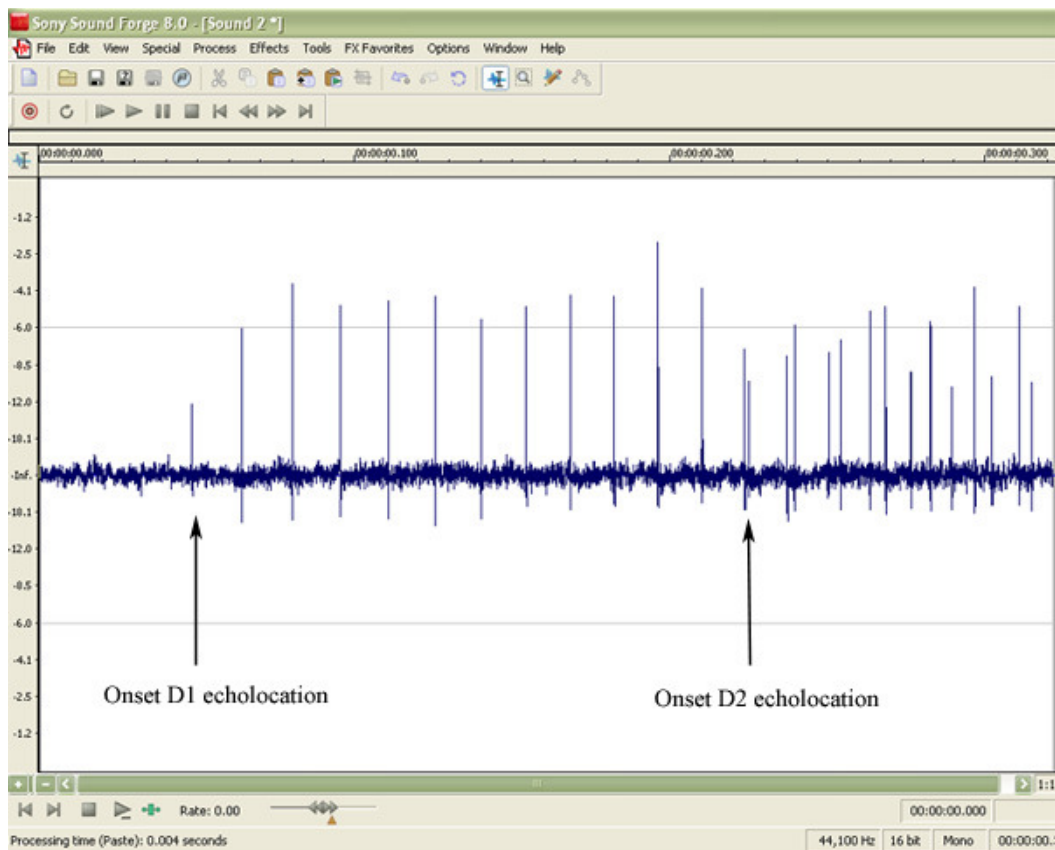

Figure 3.3.2 Waveform showing onset of D1 and D2 echolocation clicktrains

Using point-sampling methods, swim position information is sampled at 0.5 second intervals until the end of the event. To differentiate between two simultaneous click trains, peak-to-peak inter-click-

intervals are examined for regularity of occurrence and similarity of relative amplitude levels. Length of the echolocation bout is determined by measuring the occurrence of these clicks until they can no longer be distinguished from the background noise. Similar comparisons of the audio file and the video are used to determine the timing between different echolocation events in comparison to the onscreen video. If the visual click data are unclear (due to a high signal-to-noise ratio, possible click overlap, or irregular click interval periods), the episode is discarded. If there is uncertainty as to which of the two dolphins is the source of an echolocation bout, or if it is possible that a third dolphin may be responsible for the echolocation information seen on the audio display, the episode is discarded. Positional/head angle information is coded using the method described in section 3.3.3 using point-sampling methods at 0.5 second intervals. Wherever possible, the ECD audio data are examined in Sound Forge. If this audio file can be accurately matched to the echolocation activity for the episode in question, the click data from the ECD audio file are used in lieu of the video audio (see section 3.3.6). After the appropriate variables have been recorded in SPSS, a video clip of the event is saved as a separate file. The following tables (Table 3.4, Table 3.5) provide a list of variables recorded for Data Set 2: (*note, D1 is defined as the dolphin that initiates echolocation. The second dolphin (D2) is designated as the dolphin that is swimming closest to D1 at the time D1 begins echolocating on the camera. If there are two dolphins that are equidistant from D1 at the start of an episode, D2 will be the dolphin on D1's right side.)

Table 3.4: Variables for Data Set 2 – part 1

Variable name	Variable Description
Event Number	The number of the event/episode
Tape ID	The tape ID number as recorded in the DCP format
Counter Number	Counter # as displayed by the video playback software 1 second before start of D1 echolocation activity
Date	Date on Screen during event/episode
ScreenTime	The screen time as displayed onscreen 1 second before start of D1 echolocation activity
D1ID	The ID number of the dolphin as found in the DCP/MIK dolphin ID database if this can be determined
D2ID	The ID number of the dolphin as found in the DCP/MIK dolphin ID database if this can be determined
D1 age class	The age of the dolphin according to the DCP/MIK dolphin ID database if this can be determined
D2 age class	The age of the dolphin according to the DCP/MIK dolphin ID database if this can be determined
D1 Gender	The gender of the dolphin if known
D2 Gender	The gender of the dolphin if known
MC pair	Is this a mother calf pair – as determined by DCP/MIK dolphin ID database where mother/calf IDs have been confirmed
ECD confirm echolocate	Was it possible to synchronize the ECD .wav file with the video/audio file for D1's echolocation bout
TtinView	Total number of dolphins in view at start of D1 echolocation activity
TtSwimTogether	Total # of dolphins swimming in same direction as D1 at start of D1 echolocation activity
ClockfaceSwimPos1SecBeforeEvent	Clockface swimming position of D2 relative to D1 1 second before start of D1 echolocation activity
DistanceApart1SecBeforeEvent	Distance between rostrum tips of D1 to D2 1 sec before start of D1 echolocation activity
HeadAngle1SecBeforeEvent	Head angle of D1 and D2 at start of D1 echolocation activity

Table 3.5: Variables for Data Set 2 – part 2

Variable name	Variable Description
IsD1FacingCamera1Sec Before	Is D1's head aligned (within ~10 degrees) with the camera or hydrophones 1 sec before start of D1 echolocation activity
ClockfaceSwimPosition StartEvent	Clockface swimming position of D2 relative to D1 at start of D1 echolocation activity
DistanceApartStartEvent	Distance between rostrum tips D1 to D2 at start of D1 echolocation activity
HeadAngleStartEvent	Head angle of D1 and D2 at start of D1 echolocation activity
IsD1FacingCameraStart Event	Is D1's head aligned (within ~10 degrees) with the camera or hydrophones at start of D1 echolocation activity
Synched	If the two dolphins' movements were synchronizes exactly (e.g., synched breathing, turning, fluke beats, etc.) then they are 'synched'
DurationD1Echo	Duration of D1's echolocation bout in seconds. If there is a pause and the commencement of a second echolocation bout during the same event/episode, only the first bout is recorded
DidD2Shift	Did D2 change head alignment to face with ~10 degrees of the camera if not already facing the camera
TimeBetweenD1EchoD 2Shift	Time between start of D1 echolocation activity and begin of D2's head movement toward facing within 10 degrees of the camera
DidD2Echolate	Did D2 commence echolocation activity
ECDConfirmedD2	Was it possible to synchronize the ECD .wav file with the video/audio file for D2's echolocation bout
TimeBetweenD1EchoD 2echo	The time in seconds between the begin of D1's echolocation activity and the begin of D2's echolocation activity
DuractionD2Echo	Duration of D2's echolocation bout in seconds. If there is a pause and the commencement of a second echolocation bout during the same event/episode, only the first bout is recorded
*The following 4 variables are repeated at .5 second intervals for 3 seconds	
ClockfacePos.5Sec	Clockface position .5 sec after start of D1 echolocation activity
DistanceApart.5Sec	Distance between rostrum tips .5 sec after echo
HeadAngle.5Sec	Head angle of D1 and D2.5 sec after start of D1 echolocation activity
IsD1FacingCamera.5Sec	Is D1's head aligned (within ~10 degrees) with the camera or hydrophones .5 sec after start of D1 echolocation activity

3.3.3 3D model for measurements of head angle and distances

In order to obtain the measurements for the ‘distance apart’ and ‘head angle’ variables, a novel method was developed as part of this study; the ‘3D Model Analogous Scale Calculator’ (hereafter ‘3D MASC’). Various methods are used for obtaining precise positional or distance measurements to/between individuals or groups from observational research on cetaceans, for example, theodolite tracking (Bailey & Lusseau, 2004), hydrophone array triangulation (Lammers *et al.*, 2006), photogrammetry (Jaquet, 2006), and videogrammetry (Spitz *et al.*, 2000). However, these methods are not applicable to all field study situations and, consequently, observational data for cetaceans are often coded or scored based on subjective observer estimates. Several studies have employed methods for obtaining cetacean swimming proximity by estimating distance apart and stagger (i.e., length ahead/behind) (Connor *et al.*, 2006) and body length (Barrett-Lennard *et al.*, 1996) based on observer ‘eyeball’ estimation techniques. The 3D MASC method was developed for application to determining more precise positional and distance estimates between individual, wild dolphins from underwater video data. Methods that rely on simple and cost-effective techniques for measuring distance and relative size of animals from video data using handheld sonar devices in conjunction with video have been previously developed (e.g., underwater videogrammetry described by Spitz *et al.*, 2000); however, the 3D MASC technique has the advantage of obtaining estimates without the need of collecting additional data from supplementary devices in the field, as it relies solely on analysis of video data in the lab.

For this study, the video data were analyzed in order to measure the changes in body and head positions of dolphin dyads with regard to echolocation activity. In order to determine the angle of two dolphins’ heads relative to each other, and the distances that the dolphins are positioned from each other, a computer-based measurement system was established. This process involved creating an accurate 3D model of a dolphin’s head and positioning the model within a 3D CAD (computer-aided design) environment, allowing the user to recreate the scene observed in the 2D video image to scale. The software package used to both create the dolphin head model and to make the measurements was Google SketchUp®, a 3D modeling program available for download from the Internet free of charge.

The dolphin head models were created based on anatomical measurements of *T. aduncus* specimens and are represented within the 3D environment using a 1:1 scale. Two measurements were used for the model: ‘tip of the rostrum to the external nares’ (TREN) and ‘greatest width across zygomatic processes of squamosal’ or ‘zygomatic width’ (ZW), which is, for the purpose of the model, analogous to the width distance between the left and right eye. This yields four morphological points used for the model: rostrum tip, left eye, right eye and blowhole (external nares). The end points of each of these measurements for the corresponding morphological points were mapped in the 3D environment and then joined to create a 3D polygon model, which includes a line projection extending from the rostrum tip 1 m in length (‘angle indicator projection’) that is used in obtaining the

measurement of the relative angle. Initial measurements were obtained from an article that provided TREN and ZW for a *T. aduncus* specimen from the Mikura Island population (Shirakihara *et al.*, 2003). Dolphin specimen MIE003 (aged at 12 years) was used as the prototype for the ‘mature’ dolphin skull, as this dolphin is well within the range of physical maturity for this species (see Shirakihara *et al.*, 2003). Following these measurements, the ‘mature’ dolphin model has a TREN of 335 mm and a ZW of 245 mm (Figure 3.3.3).

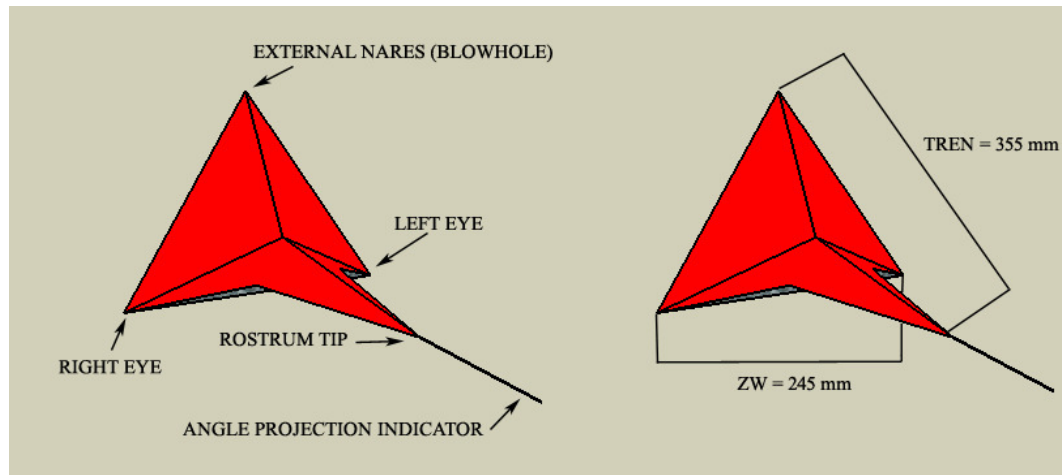

Figure 3.3.3 Example of the ‘mature’ 3D dolphin head model used in the 3D MASC method

It was necessary, however, to produce models that could represent the various age groups for the dolphins observed in this study. From the Mikura study population, the dolphins ranged in age from neonates to fully grown adults. The ‘mature’ skull would not be appropriate for representing distance and angle measurements for younger dolphins included in the video data: differing skull measures would compromise TREN and ZW estimates potentially caused by inappropriate scaling. Consequently, three additional models were created as representations of varying head/skull sizes for younger age groups (Figure 3.3.4). The four age groups represented by the four models as derived from the available skull measurements are: ‘mature’ (> 5 years; body length between 216.5 cm and 251.0 cm), ‘juvenile’ (between 2 and 5 years; body length between 188.0 cm and 195.0 cm), ‘calf’ (between 0.5 and 2 years; body length between 144.0 cm and 173.0 cm), and ‘neonate’ (between birth and 0.5 years, body length < 144.0 cm). These categories were arrived at based on comparisons of body length and known ages for the ‘mature’ specimen described in Shirakihara *et al.* (2003), two additional ‘mature’ Mikura specimens described in Kakuda *et al.* (2002) and unpublished data provided by C. Kemper showing TREN and body length measurements of seven young *T. aduncus* specimens collected from Australian waters (C. Kemper, personal communication). The measurements for the 10 specimens, ranging in age from ~2 to 12 years, can be found in Table 1.

These four age categories are not related to the typical developmental growth curves for *T. aduncus* where ‘maturity’ is often described in terms of sexual maturity (e.g., Ross, 1984), rather these categories are related to average skull sizes for the established age categories. The models for

the juvenile and calf age categories were created by scaling the 'mature' model relative to the length of the average TREN measurement for the younger dolphins (Table 1, average juvenile TREN = 282 mm, average calf TREN = 239 mm). The neonate model was scaled to a TREN length 48% that of the 'mature' prototype TREN (neonate TREN = 161 mm). This scaling is based on the Laird–Gompertz growth model of a related species (*Tursiops truncatus*) that places asymptotic neonate body length at 119.0 cm; 48% of the asymptotic body length of a mature dolphin of the same species (250.0 cm) (Stolen *et al.*, 2002). For these models, measurements from male and female specimens were averaged together for each age category, as it was assumed that any potential differences due to sexual dimorphism were likely to be negligible. Studies involving *T. truncatus* show that skull measurements do not differ significantly between sexes (see Hersh *et al.*, 1990; see Tolley *et al.*, 1995), with similar results obtained for *T. aduncus* (Wang *et al.*, 2000).

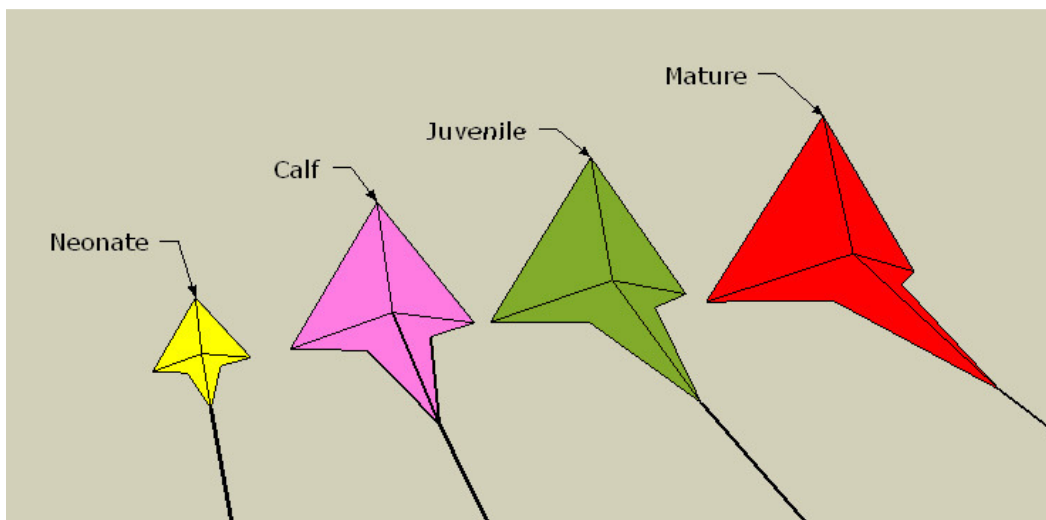

Figure 3.3.4 Head models representing the four relative dolphin age classes used in the 3D MASC method

Table 3.6 Measurements of the specimens used to arrive at 3D head models for the four age categories

Specimen	Body Length (cm)	Known Age (y)	TREN (mm)	Age Category	Source
M30133	220.0	~7.5	338.5	mature	(Kakuda <i>et al.</i> , 2002)
M32733	216.5	~4.5	329	mature	(Kakuda <i>et al.</i> , 2002)
MIE003	251.0	12	335	mature	(Shirakihara <i>et al.</i> , 2003)
M16266	155.0	unknown	250	calf	(Kemper, unpublished data)
M16608	188.0	unknown	278	juvenile	(Kemper, unpublished data)
M17595	173.0	unknown	253	calf	(Kemper, unpublished data)
M17597	144.0	unknown	214	calf	(Kemper, unpublished data)
M18053	193.0	unknown	271	juvenile	(Kemper, unpublished data)
M18057	190.0	unknown	270	juvenile	(Kemper, unpublished data)
M19965	195.0	unknown	308	juvenile	(Kemper, unpublished data)

*C. Kemper data follows the South Australian Museum Adelaide (SAMA) international code for specimens

In order to recreate the 2D scene depicting dolphin heads in a 3D environment, an image was captured from the video and imported into the 3D environment of the Google SketchUp® software. Video for which both dolphins could be identified (with age known) are used to allow determination of the appropriate 3D dolphin head model to select as best representing the likely head size of the dolphins in the video. In the few cases where the dolphin ID is not known, other physical, behavioral, and anatomical features are used to estimate the age of the dolphin(s) onscreen and therefore an appropriate 3D head model could be chosen. After selecting the appropriate sized 3D head models for each dolphin, the models are then manipulated in 3D space until the four points of each model are lined up with the corresponding morphological points on the heads of each dolphin in the 2D scene (i.e., rostrum tip, left eye, right eye, and blowhole (see Figure 3.3.5))

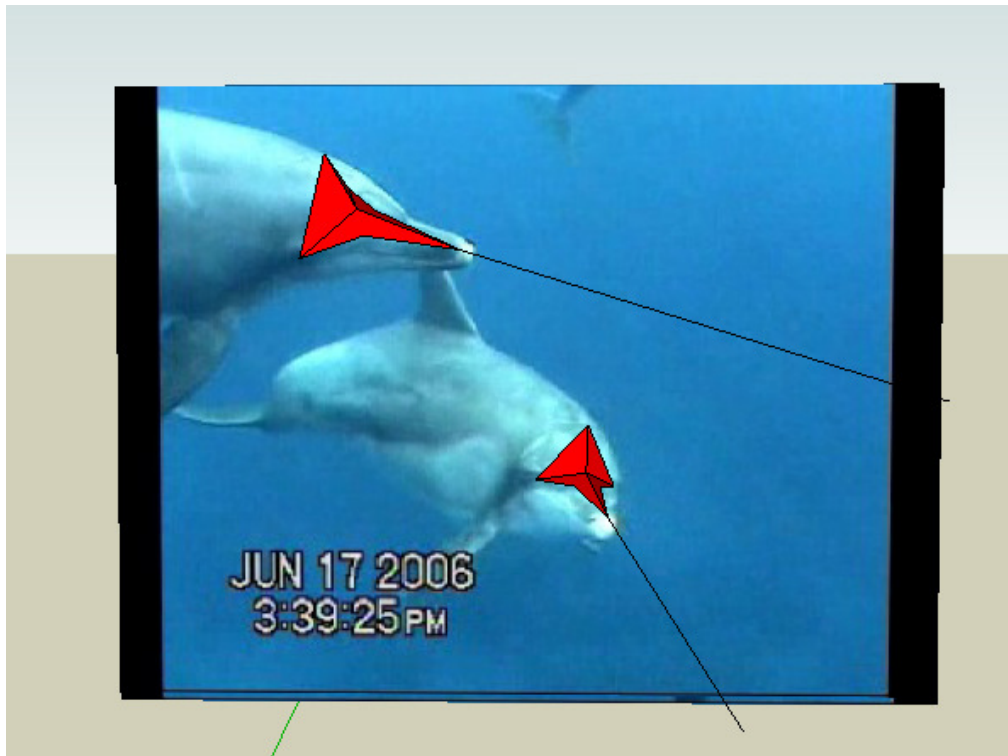

Figure 3.3.5 2D image captured from underwater video and imported into the 3D environment of Google SketchUp®

Once a match is complete, the “camera” in the 3D environment is adjusted to show a suitable view of both models for measuring distances. Using the software’s ‘tape measure’ tool, the distance between the tips of the two rostrums is measured (Figure 3.3.6). Given the scale model of the dolphin head created in the 3D environment, this provides an accurate estimate of the distance between the two rostrum tips in meters.

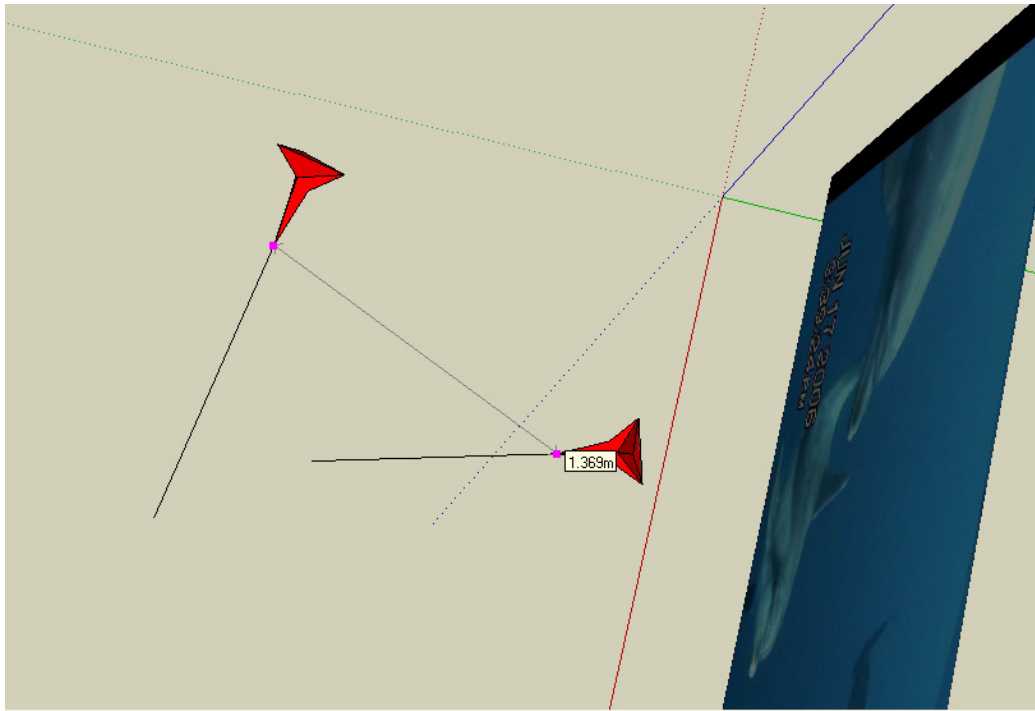

Figure 3.3.6 Models and 2D image viewed from above

To measure the relative angles of the dolphins' heads, the two models are repositioned in 3D space without changing the relative angle of the models to the X, Y, and Z axes. The rostrum tips are positioned so they exactly overlap (Figure 3.3.7). The position of the two 'angle indicator projectors' results in the formation of an isosceles triangle. The length of each of the 'angle indicator projectors' extending from the rostrum tip is exactly 1 m (sides 'b' and 'c', Figure 3.3.7). By measuring the third side ('a') using the 'tape measure' tool, the angle between the rostrums (A) can be calculated using the law of cosines: $a^2 = b^2 + c^2 - 2bc \cos A$. Rearranged to solve for angle A, the formula is:

$$\cos A = \frac{b^2 + c^2 - a^2}{2bc}$$

For the given example, side c = 1 m, side b = 1 m, and side a = .821 m. Consequently, A = 48°. Note that the relative angle of the camera to the triangle that is formed by the three sides in Figure 3.3.7 results in a 2D image that is not an isosceles triangle; measuring the sides of this 2D image will not result in measurements of 1 m for 'b' and 'c'. This renders manual measurements of angles and distances using 2D tools inaccurate. Accurate measurements can only be obtained using the known values within the 3D environment (e.g., tape measure tool, constant length of 'angle indicator projectors'). This measurement will be constant regardless of the camera angle to the models.

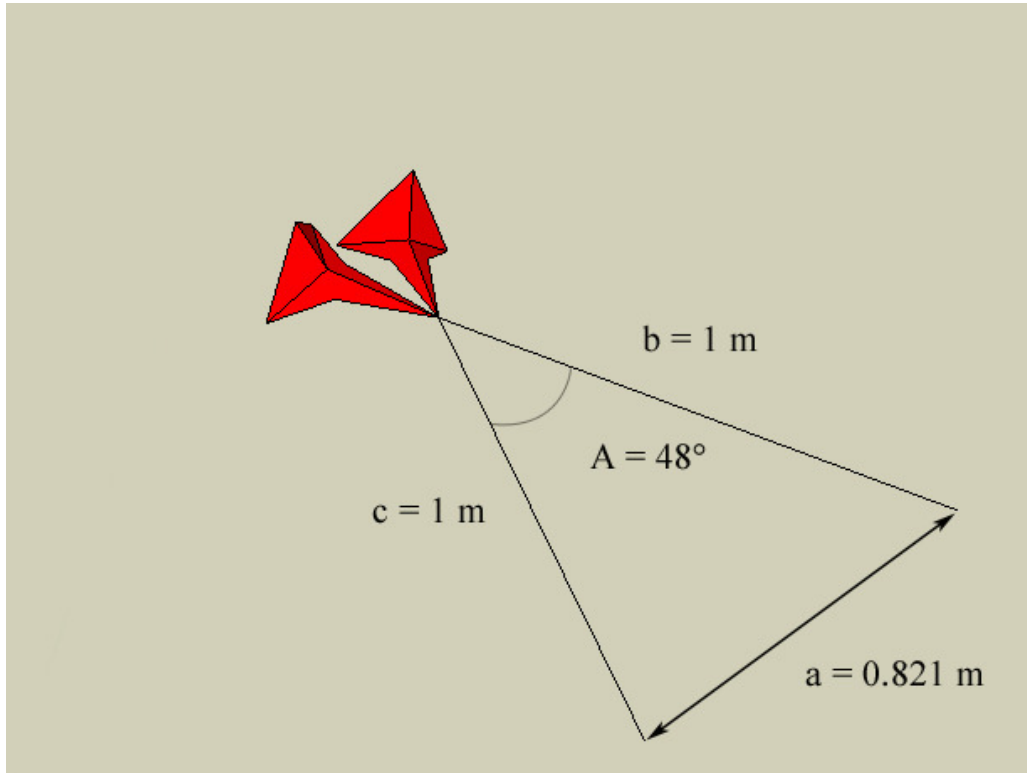

Figure 3.3.7 Models are repositioned so that the rostrum tips are aligned in the 3D environment, creating an isosceles triangle

3.3.4 Validity

A test was performed in order to determine: 1) how closely measurements obtained using the 3D MASC method match real world measurements, and 2) whether or not the 3D MASC method yields measurements that are more accurate than traditional methods. Two dummy dolphin heads with the same size and shape as the model created in the CAD environment were constructed out of boxboard. The dummy heads were placed on supporting rods and manipulated into random positions at random distances in a clutter-free environment. Seventy images of the two dummy heads were taken from random vantage points using a digital still camera, with the position of the dummy heads altered between images. For each image, the distance between the rostrum tips of the dummy heads was recorded using a tape measure. The still image for each of the dummy head positions was imported into Google SketchUp®, and the 3D MASC method was used to obtain the distance between rostrum tips. The two sets of 70 measurements were significantly and highly positively correlated ($r_{68}=0.910$, $p<0.001$), suggesting that the measurements obtained with the 3D MASC method closely match the real world measurements.

In order to test whether or not the 3D MASC method is superior to traditional distance estimation methods, a naïve experimenter (i.e., someone unaffiliated with this study) was given the opportunity to become familiar with the size and shape of the dummy dolphin heads and was then asked to view each of the 70 still images and to estimate the distance between rostrums using the 'eyeball' method

(i.e., using the depth and size cues present in the 2D image). The naïve experimenter's estimates were found to be significantly positively correlated with the real world measurements ($r_{68} = 0.789$, $p < 0.001$), although the correlation was lower than that between the 3D MASC and the real world measurements. There was also a significant positive correlation between the 3D MASC and 'eyeball' methods ($r_{68} = 0.754$), $p < 0.001$).

A test was performed to discover whether there was a significant difference between the two correlation coefficients (i.e., the correlation between the 3D MASC method and the real world measurements compared with that between the 'eyeball' estimates and the real world measurements). This test – Steiger's test for the difference between two non-independent correlations (Steiger, 1980) – revealed that the 3D MASC method correlated significantly more highly with real world measurements than did the 'eyeball' method ($t_{67} = 3.54$, $p < 0.001$). In light of the results of this test, it can be concluded that the 3D MASC method is superior to the traditional method when attempting to measure the distance between dolphin heads from video images.

3.3.5 Inter-rater reliability tests and validity

A test was performed to calculate inter-observer reliability for measurements obtained using the 3D MASC method. A naïve observer (i.e., unaffiliated with this study) was given instructions on how to use the 3D MASC method to obtain measurements for the dolphins recorded in the 2D images. After a brief training period, the naïve observer was given 15 randomly chosen 2D images/episodes and asked to record both distance and head angle using the 3D MASC method. The correlation was then calculated between these scores and those recorded independently for this study for the same sample of images. The two sets of scores were significantly and highly correlated in the case of both distance (Pearson's Correlation: $r_{13} = 0.910$, $P < 0.001$) and head angle (Pearson's Correlation: $r_{13} = 0.921$, $P < 0.001$). These results indicate that the 3D MASC method is highly reliable. Inexperienced observers seem able to quickly and easily learn this measurement technique and have it yield consistent results.

The 3D MASC method relies on scale models manipulated in a 3D environment, producing measurements that, it is hoped, are similar to real life measurements. It has been shown that 'eyeball' estimation method is subject to a variety of confounding factors, and may produce unreliable estimations. This new method attempts to limit these confounding factors by introducing mathematical techniques in combination with anatomical measurements of dolphin skulls rendered in a scale 3D environment in order to produce true-to-life estimations. Estimation errors likely come in two forms; inappropriate scale and user error. For this method to work properly, the 3D scale model of the dolphin head must be as close to the real size of the dolphin head being measured onscreen as possible. Differences in model size and the actual dolphin head size will confound the measurements. This is a particular problem for the younger dolphin head models that were derived from highly variable measurements of young *T. aduncus* specimens that were subsequently placed into arbitrary age categories. It is also important to note that the scaled 3D head models for the younger dolphins are based on estimated average head sizes, and, consequently, an appreciable margin of error exists which

could confound measurements. It should also be noted that average *T. aduncus* anatomical measurements vary somewhat between populations (e.g., South Africa, Japan, Taiwan, Australia, etc.), and the inclusion of Australian *T. aduncus* measurements as the basis for scaling of the younger dolphin models may have skewed the scale somewhat by providing non-analogous TREN measurements for the Mikura population. In terms of user error, this method requires the coder to accurately align the four morphological points in the 3D environment. Inability to line up these points accurately will not yield an analogous head position for the model, and will also bias the measurements. Despite these potential problems, this method is superior to the ‘eyeball’ estimation technique.

The 3D MASC method of determining distance between rostrums and head angle measurements between two dolphins captured on video relies on scale models manipulated in a 3D environment and produces values that mirror the “real life” situation. It is likely that employing an ‘eyeball’ estimation technique may result in a significant degree of error that may produce unreliable values for distance and head angles. The absence of stereoscopic depth and perspective cues in a 2D still or video image, as well as the unknown factor of the size scale of the objects in the scene can produce extremely unreliable distance and angle estimates (Cutting & Vishton, 1995). The new 3D MASC method aims to reduce these errors by introducing mathematical techniques in combination with true anatomical measurements of dolphin skulls rendered in a scale 3D environment in order to produce true-to-life distance and head angle estimates.

3.3.6 Reliability of the ECD and video audio data

Where it was possible, an attempt was made to use the ECD audio data for click train measurements in lieu of the audio data collected from the two conventional hydrophones recorded on the video audio tapes. It is assumed that dolphins may employ echolocation containing frequencies that are incapable of being recorded on conventional audio, potentially rendering the video audio data unusable. However, after all the data were collected and coded, the ECD data was only useful for a handful of episodes for Data Set 2. This was due to mechanical problems with the equipment, audio level problems, missing data, or other unspecified problems with the ECD data. Given the possibility that echolocation click information may be missing from the conventional audio tracks, a test was designed in order to establish the extent to which these two audio data sets are correlated (i.e., the extent to which audio data are missing from the conventional audio tracks). Audio tracks from random episodes sampled from the 2006 video data were matched against the corresponding ECD audio recorded on the DAT tapes (where this data existed). Where unambiguous audio information from each source could be reliability matched (i.e., temporally), the length of the click train as recorded on the ECD was coded, as well as the matching click train recorded on the conventional audio track. A Pearson’s Correlation (2-tailed) was then applied to these two sets of data, and revealed a highly significant correlation between click train lengths ($r_{23}=0.989$, $P<0.001$). The mean length of the click trains recorded from the conventional audio was 1.585 sec (SD=1.30), whereas the mean length of click trains for the ECD data was 1.597 sec (SD=1.39). As expected, the click train length for the

video data was shorter than from the ECD data, but this difference was (on average) only a few hundredth of a second. This is a rather remarkably high correlation, and suggests that conventional audio data is capable of detecting the presence of click trains used for this study with extreme accuracy. Thus, the audio data used during analysis is a reliable indication of the presence of dolphin echolocation for dolphins inspecting the camera.

Chapter 4 Does the Eavesdropper Remain Silent?

4.1 Overview

A behavior considered fundamental to the process of echoic eavesdropping is the suppression of echolocation by the eavesdropping dolphin. This will allow the eavesdropper to best receive echoes originating from the investigating dolphin's echolocation click echoes, while simultaneously limiting costs for echolocation production. Although this view of the need for silence has been brought into question (see section 2.1.9), it nonetheless is central to the process of echoic eavesdropping for the hypothesis in its current form. As such, this first series of tests was designed to test the first of the three hypotheses central to this study: H1 - An echoic eavesdropping dolphin remains silent for the duration of the investigating dolphin's echolocation click train during investigative events.

4.2 Baseline vs. echoic eavesdropping behavior

The first test of the silence hypothesis is designed to determine if the eavesdropping dolphin (hereafter D2) alters normal echolocation behavior in an echoic eavesdropping scenario. The question for this test is: if one dolphin of a dyad pair is echolocating on a target (the camera) is a second dolphin that happens to be present more or less likely to echolocate than normal? To answer this, it is first necessary to determine normal baseline echolocation behavior of two dolphins swimming in front of the camera (i.e., the rate at which two dolphins echolocate under 'normal' conditions). 'Normal conditions' for this test describe what should be considered the 'typical' echolocation behavior of a dolphin dyad swimming together in the presence of the camera, and not the 'typical' echolocation behavior of dolphins in general, or in other conditions (e.g., foraging, resting). To accomplish this, the 130 episodes comprising Data Set 1 were transformed into two cases for a 'baseline' sample group: 1) D2 silent and 2) D2 echolocate. The first case consist of instances where 1 (but not 2) dolphins echolocated during the recorded event (N=47). The second case consists of instances where 2 (both) dolphins echolocated simultaneously at some point during the recorded event (N=65). It should be noted that, for the baseline data set, the time intervals where 0 dolphins echolocated was not included in the sampled cases. Including cases where '0 dolphins echolocate' in the baseline data set might have biased the results because there is no possibility of 0 dolphins echolocating in the eavesdropping data set (i.e., lumping cases where 0 or 1 dolphin echolocated together would have weighted the cases unfairly toward more silence for D2). Eliminating cases from the baseline data set where 0 dolphins are echolocating will allow us to compare the eavesdropping data set (where either 1 or 2 dolphins echolocate) with the baseline data set (where, once we eliminate the 0 cases, either 1 or 2 dolphins echolocate) more uniformly, and will give a more accurate picture of what is 'normal' echolocation behavior for one dolphin (D2) when another dolphin (D1) is echolocating.

This sample was then compared to Data Set 2 consisting of dolphins in an echoic eavesdropping scenario (i.e., two dolphins swimming - not necessarily together - in front of the camera, where one of the two dolphins initiated echolocation directed at the camera). This was also divided

into the same two cases: 1) D2 silent and 2) D2 echolocate. The first case consists of instances where the second dolphin does not echolocate throughout the duration of the recorded event (i.e., during the first dolphin's echolocation bout) (N=120). The second case consists of instances where the second dolphin does echolocate at some point during the recorded event (i.e., during the first dolphin's echolocation bout) (N=50). For this test, the proportion of instances from the baseline sample group where both dolphins echolocated was 0.58, whereas the proportion of instances from the eavesdropping sample group where two dolphins echolocated was 0.29. The difference in proportions is significant for a chi-square with Yates' correction ($\chi^2=21.74$, $df=1$; $p<0.001$). This means that the eavesdropping sample group is significantly different to the baseline group in terms of D2's echolocation production, and suggests that D2 is more likely to remain silent when in an 'eavesdropping scenario' (i.e., throughout the duration of D1's initial click train production focused on the camera). This initial test allows us to reject the null hypothesis.

There is a potential problem with this method of comparison between the two data sets. It might be the case that the longer D1 echolocates (and thus the longer the overall length of the eavesdropping episode for Data Set 1), the more likely D2 is to echolocate (or, more precisely, the more likely that echolocation activity was recorded for D2 at some point). Also, it may be that D2's 'inclination' to echolocate is increased the longer D2 is exposed to D1's echolocation. Thus, perhaps the fact that the baseline episodes were, in general, longer episodes than the eavesdropping episodes, a higher rate of echolocation activity by D2 would be expected overall. However, this does not appear to be the case. A logistic regression was performed on the baseline data set, comparing the length of the recorded episode to the dependent variable (i.e., did both dolphins echolocate at some point during the event). The length of the episode was not found to be a significant predictor of whether or not two dolphins would echolocate during an episode (Odds Ratio=1.0; $df=1$; $p=0.997$). Therefore, the chi-square comparison between the two data sets is likely to be a valid test of differences between D2's echolocation activity across the sets.

Nonetheless, in order to address any potential problem caused by uneven episode lengths between data sets, two additional tests were conducted. For these tests, the eavesdropping data set was transformed. Like the baseline set, each episode in the eavesdropping set was sampled at 1 second intervals, and the number of dolphins recorded echolocating for that interval (i.e., 1 or 2) was scored. A normal curve proportions z-test was then conducted using the transformed data. The proportion that two dolphins were recorded echolocating for each episode was calculated and a mean proportion was obtained for each data set. For the baseline data set, (N=112), the mean proportion of the time for which 2 dolphins echolocated was .35. For the eavesdropping data set (N=170), the mean proportion of the time for which 2 dolphins echolocated was .19. The results of the z-test reveal a significant difference in the mean proportions ($z=5.50$, $p<0.001$), suggesting that D2 is more likely to be silent in the eavesdropping scenario. For the third test, a Mann-Whitney U was conducted with the transformed data showing proportions of the time that D2 echolocated for each episode. The baseline data (N=112, mean rank=165.33) was compared with the eavesdropping data (N=170, mean rank=125.8), revealing

significant differences in the proportions for each episode ($z=4.47$, $p<0.001$), and more silence from D2 in the eavesdropping scenario. All three of these tests (chi-square, normal curve proportions, and Mann-Whitney) reveal a significant difference between the echolocation activity of D2 in the eavesdropping scenario vs. the baseline scenario, suggesting that D2 is more silent in the eavesdropping scenario.

In order to determine possible factors that could have influenced the observed significant differences for these tests, a series of controls were implemented. These controls are outlined in the following sections.

4.2.1 Controlling for calves

A series of tests was conducted using the new sampling method for both data sets, but with the instances of mother/calf and mother/neonate dyads removed for each set. Newborn dolphins do not initially produce echolocation clicks during the first few weeks of life (Reiss, 1988); this skill appears to develop throughout the first few months after birth. Including young calves in this sample may therefore bias the sample toward less echolocation than is typical for animals possessing full echolocation capacity. Consequently, this second test removed instances of mother/calf and mother/neonate dyads from both data sets. For this study, a calf is defined as a dolphin between 0.5 and 2 years with a body length between and 144.0 cm and 173.0 cm. A neonate is defined as between birth and 0.5 years, body length < 144.0 cm. Age was usually determined through life history data on individual dolphins in the population.

The baseline data set with mother-calf pairs removed consisted of D2 Silent $N=41$ vs. D2 echolocate $N=59$. For the eavesdropping data set with mother-calf pairs removed, cases were D2 silent $N=107$ vs. D2 echolocate $N=41$. The difference in proportions is significant: chi-square with Yates' correction ($\chi^2=19.07$; $df=1$; $p<0.001$). A z-test with mother-calf pairs removed was also conducted. For the baseline data set, ($N=100$), the mean proportion of the time for which 2 dolphins echolocated was 0.59. For the eavesdropping data set ($N=154$), the mean proportion of the time for which 2 dolphins echolocated was 0.41. The results of the z-test reveal a significant difference in the mean proportions ($z=5.89$, $p<0.001$), suggesting that D2 is more likely to be silent in the eavesdropping scenario. A Mann-Whitney U with mother-calf pairs removed was also conducted. The baseline data ($N=100$, mean rank=148.62) was compared with the eavesdropping data ($N=154$, mean rank=113.79), revealing significant differences in the proportions for each episode ($z=4.12$, $p<0.001$), and more silence from D2 in the eavesdropping scenario.

With similar results to the first test series, the tests with mother/calf and mother/neonate pairs removed from the sample reveals that there is significantly more silence recorded for D2 in the eavesdropping data set. The close similarity in results here is unexpected given that immature echolocation skills for calves could have resulted in less echolocation production (Reiss, 1988); removing the calves from the sample should have changed the results if calves do behave differently

to non-calves, although perhaps the number of episodes involving calves were too few to impact the results. However, a test for significant differences in the baseline data set for episodes involving calves (N=15) and non-calves (N=130), reveal no significant differences in echolocation behavior (calf silent N=9 vs. calf echolocate N=6; non-calf silent N=65 vs. non-calf echolocate N=65); a chi-square with Yates' correction ($\chi^2=0.21$; $df=1$; $p<0.64$). A similar test on the eavesdropping data set for calves (N=17) and non-calves (N=152) still falls short of revealing significant differences (calf silent N=15 vs. calf echolocate N=2; non-calf silent N=104 vs. non-calf echolocate N=48) for a chi-square with Yates' correction ($\chi^2=2.01$; $df=1$; $p<0.16$). The conclusion here is that echolocation behavior for calves is not significantly different to that of other dolphin age groups. A potential problem with this analysis is the mixing of neonates and calves for this test. Reiss's observations concerned newborn animals (Reiss, 1988), and it is possible that by the age of 6 months a calf will have achieved adult proficiency in terms of echolocation usage. Unfortunately, there were not enough data to perform an analysis exclusively on neonates for the baseline data set (N=1) or for eavesdropping data (N=2), although it should be noted that the two instances of neonates involved in an echoic eavesdropping scenario resulted in silence from the neonates involved.

4.2.2 Controlling for distance and head angle

Given that the data comprising the baseline data set included only animals that were 'swimming together' (i.e., within approximately one body width and length of each other; the equivalent of 2 m between the rostrums), but the eavesdropping data set included unconstrained distances, a subsequent test was conducted to control for distance. It might be the case that D2 is more likely to be silent simply because he/she is too far away from D1 to be able to eavesdrop, and so these episodes could be eliminated in order to reduce potential bias. Episodes where dolphins' rostrums were >2 m apart at the start of D1's echolocation were removed from the eavesdropping data set. The cases remained the same for the baseline data set: D2 silent N=47 vs. D2 echolocate N=65. Where the eavesdropping data set was controlled for distance, the cases were: D2 silent N=104 vs. D2 echolocate N=47. A significant difference between the proportion was observed: a chi-square with Yates' correction ($\chi^2=17.96$; $df=1$; $p<0.001$), revealing more silence from D2 in the eavesdropping scenario. A z-test with distance controls was also conducted. For the baseline data set, (N=112), the mean proportion of the time for which 2 dolphins echolocated was 0.35. For the eavesdropping data set (N=151), the mean proportion of the time for which 2 dolphins echolocated was 0.21. The results of the z-test reveal a significant difference in the mean proportions ($z=4.57$, $p<0.001$), suggesting that D2 is more likely to be silent in the eavesdropping scenario. A Mann-Whitney U with distance controls was also conducted. The baseline data (N=112, mean rank=152.30) was compared with the eavesdropping data (N=154, mean rank=117.19), revealing significant differences in the proportions for each episode ($z=4.02$, $p<0.001$), and more silence from D2 in the eavesdropping scenario. The results of these tests suggest that even with the cases removed where dolphins are 'not swimming together' (i.e., > 2m apart at the start of the event) D2 in the eavesdropping data set is still more silent than the baseline data set.

Similar to the distance control, a control was implemented for head angle. For the baseline data set, all dolphins have a head angle that is approximately 90° or less, but the eavesdropping data set contains unconstrained head angles. Similar to distance, this difference may have biased the results. In order to control for this bias, cases where head angle between dolphins were >90° were removed from the eavesdropping data set. The cases remained the same for the baseline data set: D2 silent N=47 vs. D2 echolocate N=65. Where the eavesdropping data set was controlled for head angle, cases were D2 silent N=107 vs. D2 echolocate N=47. A significant difference between the proportion was observed: chi-square with Yates' correction ($\chi^2=19.03$; $df=1$; $p<0.001$), revealing more silence from D2 in the eavesdropping scenario. A z-test with head angle controls was also conducted. For the baseline data set, (N=112), the mean proportion of the time for which 2 dolphins echolocated was 0.35. For the eavesdropping data set (N=154), the mean proportion of the time for which 2 dolphins echolocated was 0.19. The results of the z-test reveal a significant difference in the mean proportions ($z=5.02$, $p<0.001$), suggesting that D2 is more likely to be silent in the eavesdropping scenario. A Mann-Whitney U with head angle controls was also conducted. The baseline data (N=112, mean rank=153.72) was compared with the eavesdropping data (N=154, mean rank=118.79), revealing significant differences in the proportions for each episode ($z=5.02$, $p<0.001$), and more silence from D2 in the eavesdropping scenario. The results of these tests suggest that, even with the cases removed where dolphins are 'not swimming together' (i.e., >90° head angle at the start of the event), D2 in the eavesdropping data set is still more silent than the baseline data set.

A final test was performed with both of these controls implemented together (i.e., distance and head angle). The cases remained the same for the baseline data set: D2 silent N=47 vs. D2 echolocate N=65. Where the eavesdropping data set was controlled for both head angle and distance, cases were D2 silent N=95 vs. D2 echolocate N=45. A significant difference between the proportion was observed: chi-square with Yates' correction ($\chi^2=15.92$; $df=1$; $p<0.001$), revealing more silence from D2 in the eavesdropping scenario. A z-test with both head angle and distance controls was also conducted. For the baseline data set, (N=112), the mean proportion of the time for which 2 dolphins echolocated was 0.35. For the eavesdropping data set (N=140), the mean proportion of the time for which 2 dolphins echolocated was 0.21. The results of the z-test reveal a significant difference in the mean proportions ($z=4.27$, $p<0.001$), suggesting that D2 is more likely to be silent in the eavesdropping scenario. A Mann-Whitney U with both head angle and distance controls was also conducted. The baseline data (N=112, mean rank=143.6) was compared with the eavesdropping data (N=140, mean rank=112.82), revealing significant differences in the proportions for each episode ($z=3.67$, $p<0.001$), and more silence from D2 in the eavesdropping scenario. The results of these tests suggest that, even with the cases removed where dolphins are 'not swimming together' (i.e., >90° head angle and >2 m apart at the start of the event), D2 in the eavesdropping data set is still more silent than the baseline data set.

On a final note, when the handful of cases in the eavesdropping data set where D2 is 'not swimming together with D1' (i.e., >90° head angle and >2 m apart at the start of the event) (N=4) are compared

to the baseline data, a significant difference is not found between data sets. Where the eavesdropping data set was transformed to include only those episodes where dolphins were not swimming together, cases were, D2 silent N=3 vs. D2 echolocate N=1. The cases remained the same for the baseline data set: D2 silent N=47 vs. D2 echolocate N=65: Fisher's exact test (2-tailed) ($p < 0.31$). This could suggest that dolphins 'not swimming together' behave the same as the 'normal' baseline dolphins. However, when the data set of dolphins 'not swimming together' is compared to the data set of dolphins 'swimming together' (both taken from the eavesdropping data set), significant differences are not found for this test either, as might be expected given the significant difference between the eavesdropping (when controlled for 'swimming together') and the baseline data sets. Where the eavesdropping data set was controlled for both head angle and distance, cases were D2 silent N=95 vs. D2 echolocate N=45. Where the eavesdropping data set was transformed to include only those episodes where dolphins were not swimming together, cases were D2 silent N=3 vs. D2 echolocate N=1: Fisher's exact test (2-tailed) ($p < 0.62$). Thus, likely due to the small sample size, these tests suggest that the dolphins in the eavesdropping data set that are 'not swimming together' have a minimal impact on the significant differences found for previous tests. The conclusion here is that, even with controls for calves, distance and head angle, there appears to be a significant difference between the eavesdropping data set, and the baseline data set in terms of D2's echolocation behavior: D2 is more silent in the eavesdropping scenario. The reasons for this difference will be explored in subsequent sections.

4.3 Exploring relationships between variables

4.3.1 Distance

There are a variety of variables in addition to those discussed in the previous sections that may affect whether or not D2 remains silent, and a series of related follow-up tests were conducted in order to explore these relationships between variables. It is possible that the distance between the two dolphins' heads at the start of the event will predict whether or not D2 echolocates during the event. If D2 is positioned too far away from D1, this may reduce the possibility that D2 could eavesdrop on D1's echolocation, and thus reduce the likelihood that D2 remains silent. Therefore, we can ask: does the distance that the two dolphins are apart at the start of the episode influence whether or not D2 echolocates during the event?

A test was conducted on the data for Data Set 2 in order to address this question. The first series of chi-square tests assumes that there is an 'ideal eavesdropping' distance (≤ 1 m apart), in which D2 is likely primed for echoic eavesdropping to occur (and thus to remain silent) (see section 5.1). Cases were divided between episodes (in the eavesdropping data set) where D1 and D2 were positioned ≤ 1 m apart, and > 1 m apart at the start of the event. The number of instances where D2 echolocated at some point during the event when ≤ 1 m distance from D1 at the start of the event: echolocated N = 30 vs. remained silent N = 53, was compared to the instances where D2 echolocated when > 1 m distance from D1 at the start of the event: echolocated N = 17 vs. remained silent N = 51. No significant

difference between the proportions was observed: a chi-square with Yates' correction ($\chi^2=1.68$; $df=1$; $p<0.2$), suggesting that there is no difference in echolocation/silence behavior of D2 when positioned ≤ 1 m from D1 vs. >1 m from D1. This initial cutoff distance of 1 m between distance categories conforms to the 'ideal eavesdropping position' as will be outlined in more detail in section 5.1. Additional tests concerning D2's echolocation behavior in relation to other distance cutoff points also revealed a lack of a significant difference using a chi-square with Yates' correction: for a 1.5m cutoff: ($\chi^2=1.46$; $df=1$; $p<0.23$) (≤ 1.5 m: echolocated $N=38$ vs. silent $N=72$; >1.5 m, echolocated $N=9$ vs. silent $N=31$, as well as for a 2m cutoff: ($\chi^2=1.69$; $df=1$; $p<0.19$) (≤ 2 m, echolocated $N=44$ vs. silent $N=87$; >2 m, echolocated $N=3$ vs. silent $N=16$). The lack of significant differences found in the chi-square series is confirmed by a binary logistic regression test; the dependent variable was a binary value (did D2 echolocate; yes or no), and the independent variable was the distance between dolphins at the start of the event. The distance was not found to be a significant predictor of whether or not D2 remained silent (Odds Ratio=1.402; $df=1$; $p=0.173$).

Subsequent models were created to test whether swim distances recorded during other time intervals might reveal a significant relationship between silence and distance. Models were created for the following time intervals: 1 sec before start of event, 0.5 sec after start, 1 sec after start 1.5 sec after start, 2 sec after start, 2.5 sec after start, and 3 sec after start. None of the models revealed significant relationships with the exception of 0.5 sec after the start, for which a weakly significant relationship was found (Odds Ratio=1.608; $df=1$; $p=0.047$). This suggests that the distance between the 2 dolphins measured at 0.5 sec after D1 begins echolocating is a (weakly) significant predictor of whether or not D2 echolocates or remains silent.

A chi-square with Yates' correction test was conducted to see if this significant relationship could be isolated to specific cut-off distance for data collected for the 0.5 sec events. No significant differences were found for either a 1 m cutoff ($\chi^2=1.29$; $df=1$; $p<0.26$) (≤ 1 m: echolocated $N=30$ vs. silent $N=55$; >1 m, echolocated $N=17$ vs. silent $N=50$, or for a 1.5 m cutoff: ($\chi^2=1.87$; $df=1$; $p<0.17$) (≤ 1.5 m, echolocated $N=38$ vs. silent $N=72$, >1.5 , echolocated $N=9$ vs. silent $N=33$). However, with a cutoff distance of 2 m, a slight significant difference between the proportion was observed: ($\chi^2=3.98$; $df=1$; $p<0.05$) (≤ 2 m: echolocated $N=48$ vs. silent $N=78$; >2 m, echolocated $N=4$ vs. silent $N=22$). The proportion of dolphins (D2) that echolocated when positioned >2 m from D1 was 0.18, whereas the proportion of dolphins that echolocated when positioned ≤ 2 m from D1 was 0.67. This suggests that after 0.5 sec from the start of D1's echolocation, D2 is more likely to remain silent when positioned more than 2 m from D1. This appears to be the only (weakly) significant relationship observed between distance and silence in the distance data set across all of the time intervals for all distances.

A series of independent sample t-tests were conducted in order to measure the differences in means between the two conditions (i.e., D2 echolocate vs. D2 silent) in relation to distance at the various time intervals. Distance was only found to be a significant predictor of whether or not D2 would remain silent at 0.5 sec ($t(150)=-2.071$; $p<0.04$), differences in means: 'D2 echolocate' (mean=1.03

m) vs. 'D2 silent' (mean=1.42 m). Like the chi-square tests, these differences were only weakly significant, and do not appear to be an overall trend across time intervals. The significant differences observed here suggest that at 0.5 sec D2 is more likely to remain silent when positioned farther away from D1.

4.3.2 *Head angle*

In addition to distance, another variable may influence whether or not D2 remains silent during a potential echoic eavesdropping scenario: head angle. We can formulate the question: does the angle of the heads between the two dolphins at the start of the episode predict whether or not D2 remains silent throughout the event? As with the distance tests, a series of chi-square tests were conducted. For the initial test, head angle categories of $\leq 10^\circ$ vs. $>10^\circ$ will serve as the initial head angle cutoff point. Again, the significance of the 10° cutoff point relates to the definition of the 'ideal eavesdropping position' as will be outlined in section 5.1. The number of instances where D2 echolocated when the dolphins' heads were at an angle $\leq 10^\circ$ at the start of the event: echolocated N=1 vs. remained silent N=7, was compared to the instances where D2 echolocated when the dolphins' heads were at an angle $>10^\circ$ at the start of the event: echolocated N=46 vs. remained silent N=96. No significant difference between the proportions was observed: given the small number of events for the $\leq 10^\circ$ variables, a 2-tailed Fisher's exact test was conducted ($p < 0.44$), suggesting that there is no significant difference in echolocation/silence behavior of D2 when the head angle of D1 and D2 is $\leq 10^\circ$ at the start of the event vs. $>10^\circ$ at the start of the event. Subsequent tests at the following angles also revealed a lack of a significant difference for head angle at the start of the event:

At 30° for start of event: The number of instances where D2 echolocated when the dolphins' heads were at an angle $\leq 30^\circ$ at the start of the event: echolocated N=13 vs. remained silent N=32, was compared to the instances where D2 echolocated when the dolphins' heads were at an angle $>30^\circ$ at the start of the event: echolocated N=29 vs. remained silent N=71. No significant difference between the proportions was observed: a chi-square with Yates' correction ($\chi^2=0.00$; $df=1$; $p < 0.99$), suggesting that there is no significant difference in echolocation/silence behavior of D2 when the head angle of D1 and D2 is $\leq 30^\circ$ at the start of the event vs. $>30^\circ$ at the start of the event.

At 60° for start of event: The number of instances where D2 echolocated when the dolphins' heads were at an angle $\leq 60^\circ$ at the start of the event: echolocated N=38 vs. remained silent N=69, was compared to the instances where D2 echolocated when the dolphins' heads were at an angle $>60^\circ$ at the start of the event: echolocated N=9 vs. remained silent N=34. No significant difference between the proportions was observed: a chi-square with Yates' correction ($\chi^2=2.39$; $df=1$; $p < 0.12$), suggesting that there is no significant difference in echolocation/silence behavior of D2 when the head angle of D1 and D2 is $\leq 60^\circ$ at the start of the event vs. $>60^\circ$ at the start of the event.

At 90° for start of event: The number of instances where D2 echolocated when the dolphins' heads were at an angle $\leq 90^\circ$ at the start of the event: echolocated N=44 vs. remained silent N=90, was

compared to the instances where D2 echolocated when the dolphins' heads were at an angle $>90^\circ$ at the start of the event: echolocated $N=3$ vs. remained silent $N=13$. No significant difference between the proportions was observed: a chi-square with Yates' correction ($\chi^2=0.75$; $df=1$; $p<0.39$), suggesting that there is no difference in echolocation/silence behavior of D2 when the head angle of D1 and D2 is $\leq 90^\circ$ at the start of the event vs. $>90^\circ$ at the start of the event.

The lack of significant differences between the conditions found in the chi-square series is confirmed by a binary logistic regression test for head angle at the start of the event. For this model, the dependent variable is a binary value (did D2 echolocate: yes or no), and the independent variable was the head angle between dolphins at the start of the event. The model does not find that head angle is a significant predictor of whether or not D2 will remain silent (Odds Ratio=1.012, $df=1$; $p=0.058$). However, a model incorporating head angle measurements between D1 and D2 at other time intervals (0.5 sec, 1 sec, 1.5 sec, 2 sec, 2.5 sec, 3 sec) did reveal that head angle measurement for these intervals were a significant predictor of whether or not D2 remained silent. Table 4.1 shows the results of individual logistic regression models for each of the time intervals (note that multiple 'time interval' variables in the same model would have produced undesirable serial correlation/autocorrelation, and so each model was rendered individually).

Table 4.1 Logistic regression model for head angle variables at various time intervals

	B	S.E.	Wald	df	Sig.	Exp(B)
Head Angle .5 Sec	.013	.006	4.435	1	$P<0.035$	1.013
Head Angle 1 Sec	.022	.007	9.274	1	$P<0.002$	1.022
Head Angle 1.5 Sec	.018	.007	5.517	1	$P<0.019$	1.018
Head Angle 2 Sec	.023	.010	5.364	1	$P<0.021$	1.023
Head Angle 2.5 Sec	.025	.012	4.197	1	$P<0.041$	1.025
Head Angle 3 Sec	.047	.022	4.557	1	$P<0.033$	1.048

It should be noted that, for this test series, it could be argued that a Bonferroni correction should be applied to the p values. This correction is sometimes necessary when a series of tests are performed on the same data set, possibly yielding spurious p values. When the alpha value is then corrected for the above series using the Bonferroni correction, significance for these tests is found at 0.008 and not 0.05. This correction reveals that only head angle measured at 1 sec appears to reliably predict silence. Without the correction, all time intervals reveal that head angle is in fact a significant predictor of silence. However, it may not in fact be the case that a Bonferroni correction is required for this test series. Furthermore, the overall validity of the Bonferroni test has been called into question (See Perneger, 1998), and so a note of caution should be issued for these corrected results.

A subsequent logistic regression was performed on the same data (Table 4.2), however for this test, additional controls were implemented. Instances where head angle was recorded for time intervals where D1 was no longer echolocating were removed. This was done in order to remove potential bias for instances where D2 may be echolocating on the camera, but where D1 has stopped echolocating, and may no longer be facing the camera. If these instances were included, this would provide a ‘false’ description of an eavesdropping scenario; in these instances, D2 is no longer (potentially) reacting to D1’s head angle for an echoic eavesdropping scenario, as D1 has ‘removed himself’ from the inspection process.

Table 4.2 Logistic regression model for various time intervals controlled for D1 cease echolocation

	B	S.E.	Wald	df	Sig.	Exp(B)
HeadAngle.5Sec	.013	.006	4.435	1	P<0.035	1.013
HeadAngle1Sec	.023	.007	9.648	1	P<0.002	1.023
HeadAngle1.5Sec	.018	.008	5.490	1	P<0.019	1.018
HeadAngle2Sec	.023	.010	5.281	1	P<0.022	1.023
HeadAngle2.5Sec	.028	.013	4.307	1	P<0.038	1.028
HeadAngle3Sec	.050	.023	4.566	1	P<0.033	1.051

The results for this regression model with the control for D1’s cessation of echolocation activity produced results nearly identical to the uncontrolled model, suggesting limited or no influence of these variables. As in the previous series, a Bonferroni correction reveals a *p* value reaching significance only for the 1 sec measurements. Excluding the results of the Bonferroni correction, both of these models indicate that, unlike the head angle at the start of the event, head angle is a significant predictor of whether or not D2 will echolocate/remain silent when measured at all other time intervals. A series of chi-square tests were conducted in order to determine where the cutoff angle was that is likely responsible for the significant relationship observed between head angle and echolocation behavior for each of these time intervals. Results of these tests are available in Table 4.3.

Table 4.3 Chi-square with Yates' correction tests at various angle cutoff points for each time interval

Time Interval and Angle	Yates χ^2 Value	Asymp. Sig. (2-sided)	df	Proportion Echolocate under cutoff	Proportion Echolocate over cutoff
.5 sec at 10°	0.651	p<0.420	1	.5	.30
.5 sec at 30°	1.565	p<0.211	1	.41	.28
.5 sec at 60°	3.452	p<0.063	1	.37	.21
.5 sec at 90°	0.255	p<0.613	1	.32	.24
1 sec at 10°	0.352	p<0.553	1	.45	.32
1 sec at 30°	3.629	p<0.057	1	.45	.28
1 sec at 60°	4.582	p<0.032	1	.39	.18
1 sec at 90°	2.896	p<0.089	1	.36	.12
1.5 sec at 10°	0.774	p<0.379	1	.54	.37
1.5 sec at 30°	3.811	p<0.051	1	.5	.28
1.5 sec at 60°	1.901	p<0.168	1	.44	.25
1.5 sec at 90°	1.376	p<0.241	1	.42	.18
2 sec at 10°	0.000	p<1.000	1	1.0	.46
2 sec at 30°	6.877	p<0.009	1	.64	.28
2 sec at 60°	3.797	p<0.051	1	.53	.17
2 sec at 90°	1.930	p<0.165	1	.5	.14
2.5 sec at 10°	0.110	P<0.741	1	.33	.5
2.5 sec at 30°	0.308	P<0.579	1	.54	.42
2.5 sec at 60°	3.075	P<0.080	1	.54	.18
2.5 sec at 90°	Insufficient data				
3 sec at 10°	2.346	P<0.126	1	1	.45
3 sec at 30°	1.298	p<0.255	1	.62	.38
3 sec at 60°	Insufficient data				
3 sec at 90°	Insufficient data				

In the chi-square tests where significant differences were found (in bold), a difference was seen in the echolocation activity between the two groups (i.e., between those dolphin with head angles below the cutoff angle vs. those with head angles above the cutoff angle). A single case is illustrated here by way of explanation. For a 30° cutoff angle at 2 sec: the number of instances where D2 echolocated when the dolphins' heads were at an angle $\leq 30^\circ$ at the start of the event: echolocated N=21 vs. remained silent N= 12, was compared to the instances where D2 echolocated when the dolphins' heads were at an angle $>30^\circ$ at the start of the event: echolocated N=9 vs. remained silent N=23. A

significant difference between the proportion was observed: ($\chi^2=6.88$; $df=1$; $p<0.01$), suggesting that there is a significant difference in echolocation/silence behavior of D2 when the head angle of D1 and D2 is $\leq 30^\circ$ 2 second into the event vs. $>30^\circ$ 2 second into the event. The proportion of dolphins that echolocated when $\leq 30^\circ$ was 0.64, whereas the portion that echolocated when $> 30^\circ$ was 0.28, suggesting that when the two dolphins' heads are within 30° of each other after D1 has initiated echolocation for 2 second, D2 is *more likely* to echolocate on the camera than when the angle is $>30^\circ$. Given that $\leq 30^\circ$ is a 'better' eavesdropping position than $>30^\circ$ (see section 2.1) this result is the opposite of what the echoic eavesdropping predicts. The proportion of echolocating/silent dolphins for the other chi-square test where significant differences were found (1 sec, 60°) suggests a similar conclusion: dolphins with head angles below the cutoff angle are more likely to echolocate than those above the cutoff angle. A Bonferroni correction on this test series suggests that only the measurement at 2 sec and 30° reveals significant differences, if significance is to be found at an alpha value of 0.0125 (where the correction is applied only to a series incorporating the 4 angle measurements). If a Bonferroni correction is applied to the entire series, significance is found at 0.002 suggesting that none of the measurements reveal significant differences. Again, this correction may not be required or desirable.

In order to explore the relationship between head angle and echolocation activity more thoroughly, and to try to explain why D2 appears to echolocate more often with a closer head angle relative to D1, a series of independent sample t-tests were conducted for each of the time intervals (see Table 4.4). This series of tests will yield a more exact measure of the differences in means between the two conditions (i.e., D2 echolocate vs. D2 silence) in relation to head angle measurements.

Table 4.4 Independent sample t-tests for head angle at various time interval in relation to echolocation activity

	T	df	Sig. (2 tailed)	D2 Echolocate	N	Mean	Std.	Std.
						Head Angle	Deviation	Error Mean
Start of Event	-1.926	148	.056	1.00 Yes	47	40.50	28.55	4.16
				2.00 No	103	53.20	40.87	4.02
.5 sec	-2.158	150	.032	1.00 Yes	47	43.60	32.04	4.67
				2.00 No	105	55.59	31.48	3.07
1 sec	-3.290	135	.001	1.00 Yes	45	35.25	25.66	3.83
				2.00 No	92	54.28	34.38	3.58
1.5 sec	-2.497	93	.014	1.00 Yes	37	33.19	29.25	4.81
				2.00 No	58	50.79	35.94	4.72
2 sec	-2.545	63	.013	1.00 Yes	30	31.01	23.74	4.33
				2.00 No	35	50.03	34.53	5.84
2.5 sec	-2.260	48	.028	1.00 Yes	24	30.18	14.66	2.99
				2.00 No	26	48.31	36.67	7.19
3 sec	-2.490	35	.018	1.00 Yes	19	22.49	13.38	3.07
				2.00 No	18	38.12	23.67	5.58

A significant difference between the mean head angle measurements was found for all time intervals. Excluding the results of a Bonferroni correction (whereby only the 1 sec p value reaches significance at 0.007), this analysis suggests that dolphins echolocate more often when head angles are closer together. Generally, silence appears to be more prevalent when mean head angles are $\sim 45^\circ$ or above. This trend may be caused by the fact that dolphins facing above 45° are unlikely to be focusing attention on the camera, and thus less likely to engage echolocation on the camera in the first place. This is perhaps supported by the findings for the distance t-tests where it appears that silence occurs more often when dolphins are positioned farther apart. Although it is also possible to conclude that dolphins are more likely to engage in eavesdropping (i.e., remain silent in order to listen to D1's clock echoes more efficiently) when their heads are above a 45° angle, and that this may in fact be a 'better' position for echoic eavesdropping. This is not predicted by the echoic eavesdropping hypothesis and seems somewhat improbable, although an alternate hypothesis may explain this trend (see section 6.2.2.2). A lack of a significant difference for the chi-square series for various head angles cutoff points does not help explain how silence is related to 'ideal' eavesdropping angles. In any event, these tests do not provide evidence that closer distances and closer head angles are correlated with silence; they in fact suggest the opposite. The relationship between silence/echolocation and 'ideal eavesdropping positions' will be more thoroughly in section 5.5.4.

4.3.3 Distance and head angle combined

Although distance seems to have limited predictive power concerning whether or not D2 will echolocate, a slightly stronger relationship does exist between head angle and D2's echolocation activity at some time intervals and for some angles. It is interesting to then examine if a relationship exists between distance and head angle in general. A Pearson's Correlation (2-tailed) was applied to these two variables (i.e., distance and head angle) for each of the sampled time intervals for the eavesdropping data set. Results of each individual test can be found in Table 4.5.

Table 4.5 Pearson's Correlation – distance and head angle at all time intervals

	Pearson Correlation r^2	Sig.
1 sec before	.500(*)	.000
start event	.347(*)	.000
.5 sec after	.305(*)	.000
1 sec after	.507(*)	.000
1.5 sec after	.422(*)	.000
2 sec after	-.114	.365
2.5 sec after	.365(*)	.009
3.5 sec after c	.534(*)	.001

*Correlation is significant at the 0.01 level (2-tailed).

Despite the fact that distance was only a weak predictor of whether or not D2 would remain silent, and head angle was a much stronger predictor, it appears that distance and head angles themselves are correlated. With a Bonferroni correction (significance at 0.007), significant differences are still found for all cases except 2 sec and 2.5 sec. This correlation however could not be fit to a regression model, linear or otherwise. An example of an indistinct linear regression plot it found in Figure 4.3.1. Thus, while it can be stated that there is a relationship between distance and head angle, it is not correct to state that the farther apart two dolphins are from each other, the farther apart their head angles will be, as might be assumed.

head angle of D2 1 sec after start D1 echolocate

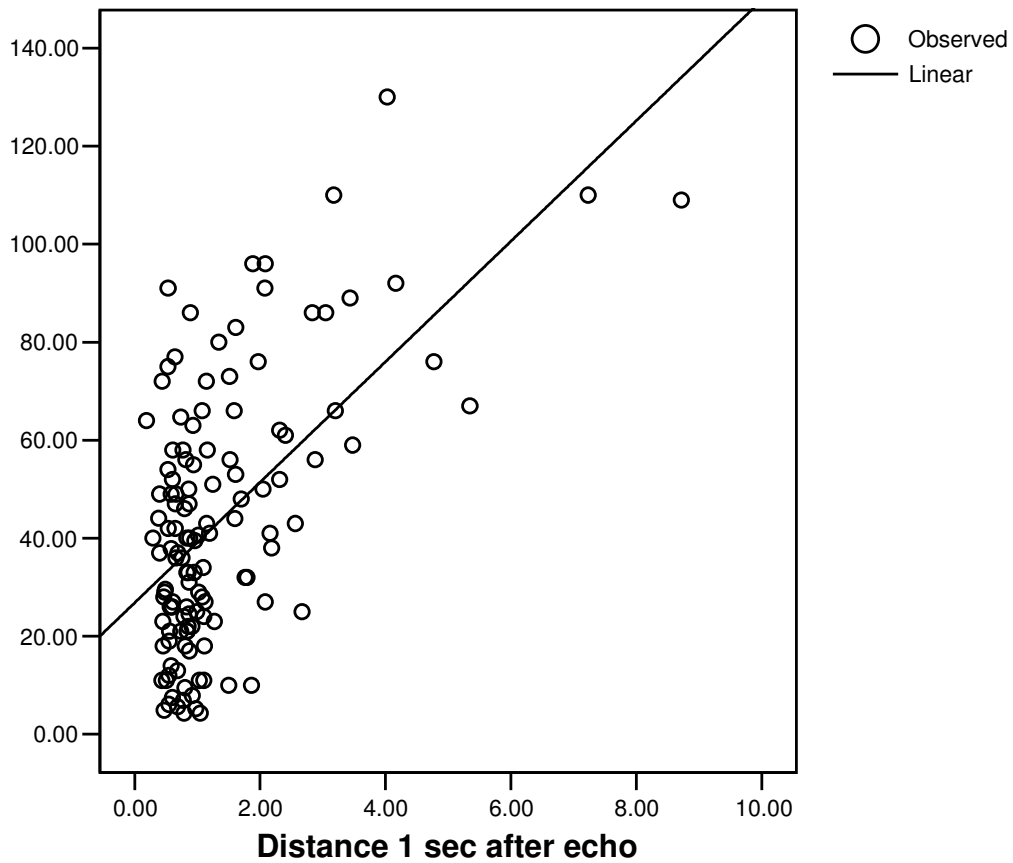

Figure 4.3.1 Regression of angle vs. distance at 1 sec with outliers 2SD of the mean removed

The overall conclusion when examining the relationship between variables is that D2 appears to remain significantly more silent when not swimming in the vicinity of D1 – possibly because D2 is not in a position to notice or develop interest in inspecting the camera. It should be noted here that in section 4.2, D2 was found to remain significantly more silent than ‘normal’ dolphins when swimming ‘together’ with D1 and NOT when swimming farther apart. Therefore, even though head angle and distance were not themselves predictors of whether or not D2 would remain silent when ‘swimming together’ with D1, D2 is still, overall, significantly more silent in this condition when compared to ‘normal’ baseline dolphin behavior. Distance and head angle are only predictors when we measure their effects on larger distances and head angle (i.e., $>45^\circ$).

4.3.4 Clockface swimming position

A test was also conducted to determine if the clockface swimming position of D2 in relation to D1 was a predictor of whether or not D2 would echolocate. Clockface swimming position was scored

under the categories of 12:00, 1:30, 3:00, 4:30, 6:00, 7:30, 9:00, and 10:30, and describes the position at which D2 is positioned relative to D1 as the ‘center’ of the clock (see Figure 4.3.2. Logistic regression was performed for these categories at each time interval. No significant relationship was found for any of these models (i.e., clockface swimming position is not a predictor of D2’s echolocation behavior).

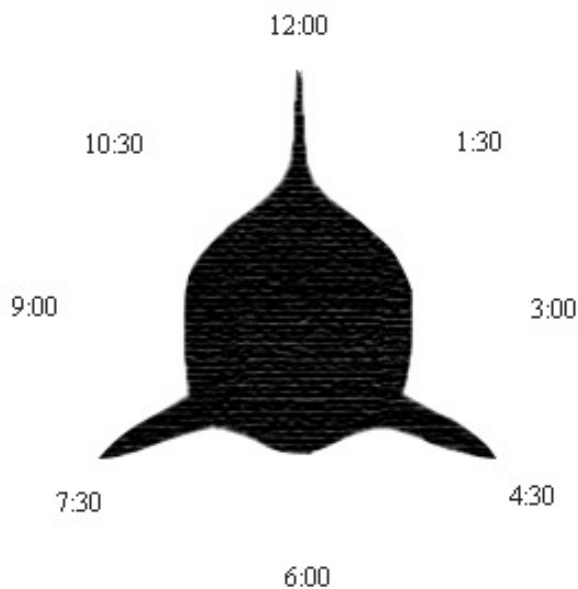

Figure 4.3.2 Clockface swimming position

4.3.5 Gender

A test to determine if the gender of either D1 or D2 affects whether or not D2 remains silent or echolocates was conducted. To begin, it was determined that the role that a dolphin assumes (either that of D1 or D2) is not influenced by gender. The number of male dolphins in the role of D1 were N=23 vs. females N=99. The number of male dolphins in the role of D2 were N=24, vs. females N=62. Results did not show a significant difference in the proportion insofar as neither males nor females tended to prefer either role: a chi-square with Yates’ correction ($\chi^2=1.88$; $df=1$; $p<0.17$). Further tests were conducted to examine the relationship between the gender of either dolphin and D2’s echolocation activity. Where the normal gender frequency for D1 (male N=23 vs. female N=99) was compared to the D1 gender frequency for instances where D2 remained silent (male N=14 vs. female N=71), no significant difference was found a chi-square with Yates’ correction ($\chi^2=0.07$; $df=1$; $p<0.8$). Where the normal gender frequency for D1 (male N=23 vs. female N=99) was compared to the D1 gender frequency for instances where D2 echolocated (male N=9 vs. female N=28), no significant difference was found: a chi-square with Yates’ correction ($\chi^2= 0.24$; $df=1$; $p<0.62$). Where the normal

gender frequency for D2 (male N=24 vs. female N=62) was compared to the D2 gender frequency for instances where D2 remained silent (male N=14 vs. female N=42), no significant difference was found: a chi-square with Yates' correction ($\chi^2= 0.04$; $df=1$; $p<0.84$). Where the normal gender frequency for D2 (male N=24 vs. female N=62) was compared to the D2 gender frequency for instances where D2 echolocated (male N=10 vs. female N=20), no significant difference was found: a chi-square with Yates' correction ($\chi^2= 0.11$; $df=1$; $p<0.74$). The conclusion here is that the gender of either D1 or D2 has absolutely no effect on the echolocation behavior of D2.

4.3.6 Click train duration and other factors

The mean length of D1's initial echolocation click train (from the eavesdropping data set) is 2.094 sec (SD=1.64). It is within this mean time interval that a significant difference was seen between this data set, and the baseline data set. Given that there may be no reason to assume that episode length is a factor that has biased our results of significant differences between baseline and eavesdropping data sets (see section 4.2), it might be the case that the first 2 sec after D1 initiates echolocation are in fact significantly different to all other 'normal' time periods of dolphins swimming together on screen (a reason to reject the null hypothesis). However, there are other factors and behaviors occurring within this 2 sec window that may explain the significant occurrence of silence seen in previous tests. The mean time delay between the onset of D1's echolocation click train and the onset of D2's echolocation click train for those episodes where D2 *did not* remain silent was 1.37 sec (SD=0.914). Thus, even for episodes where D2 does echolocate (as opposed to those where D2 remains silent throughout the episode) there is still a 1.37 sec delay before D2 initiates echolocation. It is possible that this delay is another example of silence due to echoic eavesdropping. However, it should be noted that the mean time it takes D2 to move his/her head from a position when D2 is 'not facing the camera' to a position where D2 faces the camera (for episodes where D2 both remains silent and echolocates) is 0.99 sec (SD=0.71). This may suggest that the apparent silence observed before D2's echolocation onset is nothing more than a byproduct of the time it takes D2 to face the camera after D1 begins an echolocation bout (i.e., that D2 will not engage echolocation until facing the camera, thus there is a 'mechanical' movement delay). A Pearson's Correlation (2-tailed) was applied to these two variables, that is, the time between D1's echolocation onset and D2's head turn and the time between the start of D1's echolocation bout and D2's echolocation bout ($r_{42}=0.690$, $P<0.001$). Thus, there is a correlation between the time it takes D2 to face the camera and the time delay before D2 engages echolocation. Furthermore, it should be noted that the mean time delay between D1's echolocation onset and D2's echolocation onset for those episodes where D2 is already facing the camera when D1 begins echolocation is 0.39 sec (SD=0.36). This much shorter delay seems to confirm the idea that factors other than echoic eavesdropping may explain the 1.37 sec delay between D1 and D2's echolocation bouts, that is: it takes ~1 sec for D2 to move his/her head to face the camera, in addition to the mean 0.39 sec delay that appears to be usual between D1 and D2's echolocation bouts. When summed, these two means are almost identical to the 1.37 sec mean delay that appears to exist before D2 engages echolocation on the whole.

There is however an important problem with this explanation: there appears to be a relationship between the length of D1's echolocation click train, and the time delay between D1's echolocation onset and D2's echolocation onset for those episodes where D2 engaged echolocation on the camera. A Pearson's Correlation (2-tailed) was applied to these two variables (i.e., the delay before D2's echolocation onset and the length of D1's echolocation train) ($r_{51}=0.414$, $P=0.003$), revealing a correlation between the two variables. A regression plot of this potentially linear relationship (with outliers removed) is seen in Figure 4.3.3. This relationship appears to challenge the notion that the D2's delay in engaging echolocation is related to mechanical explanations, as it appears to be correlated with the length of D1's echolocation click train.

Delay between D1 ad D2 echolocation onset

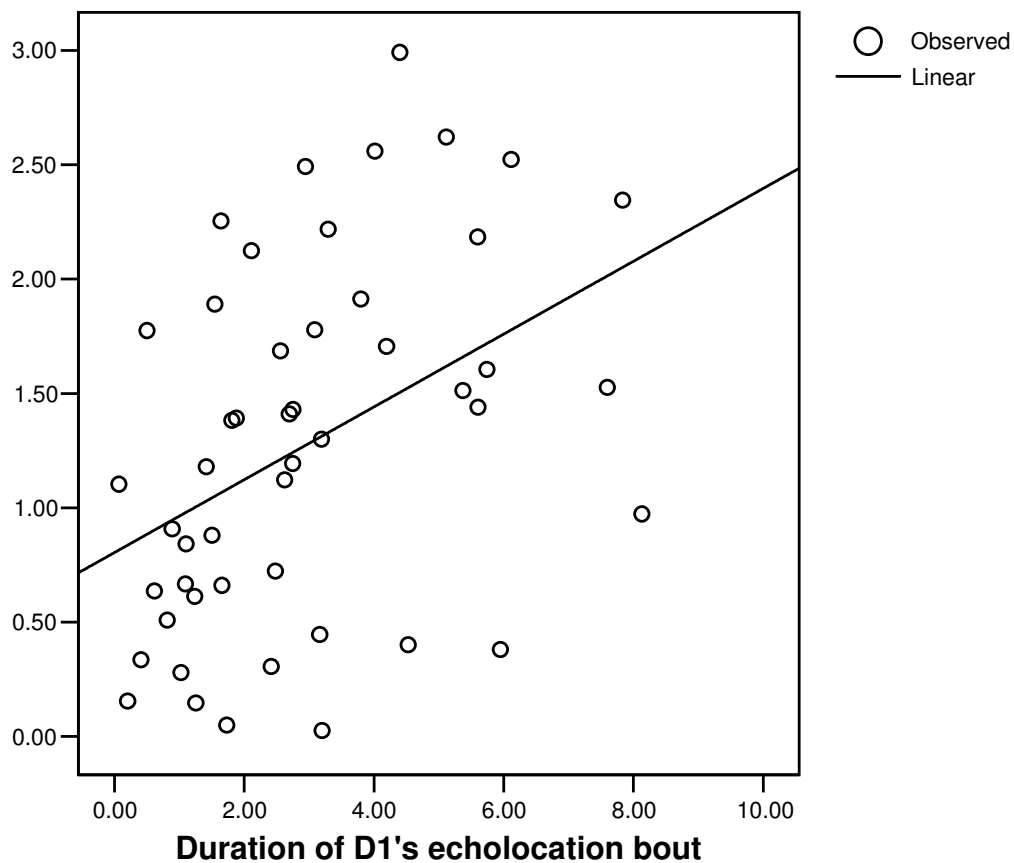

Figure 4.3.3 Regression of duration D1's echolocation bout vs. delay between D1 and D2's echolocation

The conclusion here is that for the eavesdropping data set, D2 is a more likely to remain silent when compared to the normal baseline behavior of dolphin dyads, and that there is no reason to suspect that outside factors have contributed to this silence other than the presence/onset of D1's echolocation.

And in those episodes of the eavesdropping data set where D2 does engage echolocation, the amount of time that D2 remains silent before engaging echolocation appears to be related to the length of D1's echolocation click train. These tests provide enough evidence to reject the null hypothesis at this stage, and to conclude that D2's silence is in some way caused by D1's initial echolocation activity on the camera.

An additional test of general interest is to determine if there is a relationship between the length of D1's echolocation click train and the length of D2's echolocation click train. Although not strongly significant, a weak relationship was found for a Pearson's Correlation (2-tailed) for these two variables: ($r_{51}=0.314$, $P=0.025$) suggesting a possibility that the longer the click train for D1, the longer the click train of D2. However with outliers two times the standard deviation of the mean removed, a linear relationship was not seen for a regression plot (Figure 4.3.4). The conclusion here is that the length of D1's click train has limited or no affect on the length of D2's click train, and that if a relationship does exist, it is not linear.

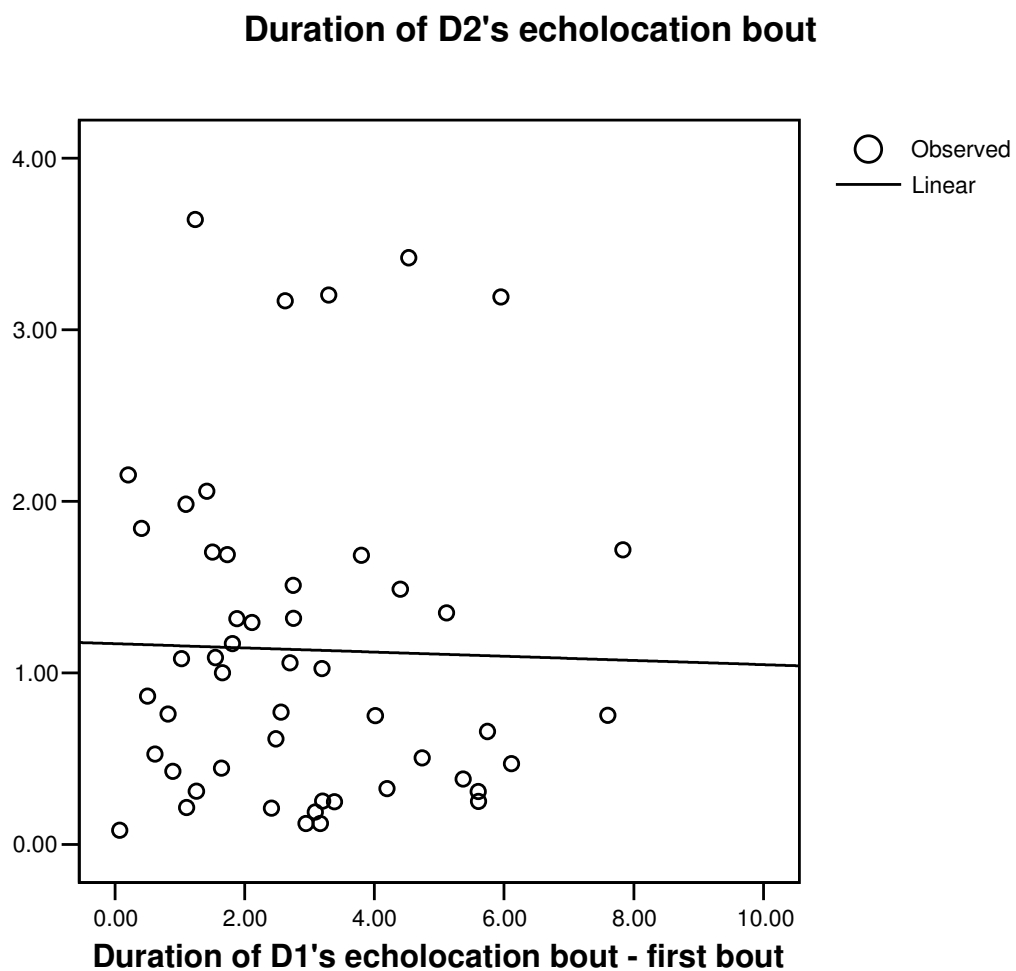

Figure 4.3.4 Regression of length of D1 vs. D2 echolocation train – outlier removed

An additional test looked at the possible influence that the presence of echolocation activity by a second dolphin might have on the length of the first dolphin's echolocation click train. When looking at the data from the baseline data set, the mean length of a dolphin's click train for those episodes in which only 1 dolphin echolocates was 3.72 sec (SD=2.12). The mean length of a dolphin's click train when both were echolocating simultaneously (measuring the length of time that both dolphins' click trains were recorded together) is 2.83 sec (SD=1.94). Given this, it might be possible to conclude that D1 echolocates longer when not 'interrupted' by D2. However, this test might be misleading as it only measures the length of those episodes where two dolphins echolocate simultaneously in order to achieve the second variable. It may well be the case that when one dolphin begins a click train, a second dolphin joins in for a few seconds and then stops, while the first dolphin continues on – or perhaps the first dolphin stops and the second dolphin continues on. Thus, the length of either dolphin's click train may in fact be equal to the 'normal' click train length for a dolphin echolocating by itself, but this length is not revealed in the sample. In order to control for this, the second variable was re-sampled, this time counting the entire length of the episode in which 2 dolphins are recorded echolocating at some point during the episode. As expected, this increases the mean length of the click train episode to 4.98 sec (SD=2.73). The conclusion here is that, for the baseline data set, a second dolphin's echolocation activity does not appear to influence the first dolphin's echolocation at least in terms of click train length (i.e., one dolphin echolocating alone does not echolocate longer than those episode where he/she is 'interrupted' by a second dolphin).

A final test focusing on the eavesdropping data set found that there is an important relationship between the length of D1's click train between episodes where D2 remained silent or echolocated. An independent t-test found a highly significant difference between the mean length of D1's click train for those episodes where D2 echolocated and where D2 remained silent ($t(168)=4.714$; $p<0.001$). The mean length of D1's click train when D2 remained silent was 1.73 sec (SD=1.29) whereas the mean length when D2 echolocated was 2.96 sec (SD=2.03). This may suggest that D1 will echolocate longer when exposed to the echolocation clicks of D2.

Chapter 5 Does the Eavesdropper Remain in or Initiate an Ideal Eavesdropping Position?

5.1 Defining the OZE

Perhaps the most fundamental set of behaviors both indicative of, and resultant from echoic eavesdropping, is changes in swim position. Although it has been pointed out that there are a variety of concerns when attempting to describe the mechanisms involved in echoic eavesdropping as it relates to the ‘ideal’ swim position (see section 2.1), the results of Xitco and Roitblat’s (1996) experiment provide the necessary parameters that have allowed for the formulation of two hypotheses relating to potential echoic eavesdropping behavior in wild dolphins:

H2 – A dolphin positioned in an appropriate eavesdropping position when another dolphin initiates echolocation remains in that swim position throughout the duration of the investigating dolphin’s echolocation click train during investigative events

H3 – A dolphin not positioned in an appropriate eavesdropping position when another dolphin initiates echolocation will attempt to initiate an appropriate swim position after the begin of the investigating dolphin’s echolocation click train during investigative events

Positive results for the Xitco and Roitblat’s (1996) experiment were obtained for dolphins in a specific eavesdropping position described in their article. Despite the possible diversity that could exist for ‘appropriate listening positions’ (see section 2.1), the results for this experiment led to the definition of an ‘appropriate listening position’ (found in H2 and H3) as derived from these experiments, what I will term here the Optimal Zone for Eavesdropping (hereafter referred to as the OZE). The OZE, as derived from the Xitco and Roitblat experiment, can be characterized as the following (for a dolphin dyad):

- The two dolphins’ rostrums positioned between 30 and 40 cm apart
- The two dolphins’ rostrums oriented within 5° of each other

I will alter the constraints for the OZE for the tests used in this study, following from other descriptions of dolphin echolocation. Echolocation receiving beam pattern experiments for bottlenose dolphins (*Tursiops truncatus*) have revealed that the major axis of the vertical receiving beam at 120 kHz to be 10° and for the horizontal beam 13° (Au, 1993; Au & Moore, 1984). Given these findings, the estimations of ‘appropriate head angle’ for the OZE will be the eavesdropping dolphin’s (D2) head positioned within 10° of the investigating dolphin’s head orientation in both the horizontal and

vertical plane (an overall measurement of 10° using the 3D MASC technique). This increases the size of the angle slightly from what is found in the Xitco and Roitblat experiment, but should still allow D2 to receive echoes comparable to those received by the investigator for frequencies occurring at 120 kHz or less. Furthermore, the distance between the two rostrums has been increased to 1 m, a distance that should still allow for access to undistorted echoes occurring at 120 kHz, and likely a more ‘natural’ potential distance between dolphin heads in the wild.

The measurements used in the definition of the OZE are arbitrary insofar as it is still not known which listening positions may allow for echoic eavesdropping to occur naturally. However, these measurements conform to the constraints offered by the current version of the echoic eavesdropping hypothesis and the evidence from the Xitco and Roitblat experiment describing listening positions that have been proven to allow for echoic eavesdropping to occur. The nature of the data collected for this study allows for a re-definition of the OZE during analysis; that is, it is possible to alter the parameters of the OZE and re-run the tests for echoic eavesdropping behaviors. Thus, the ‘appropriate listening position’ variable in H2 and H3 may be adjusted to explore the possibility that an ‘appropriate listening position’ may in fact occur outside the parameters currently in use for the OZE. At present, the OZE as defined for this study contains the following parameters:

- The two dolphins’ rostrums positioned ≤ 1 m apart
- The two dolphins’ rostrums oriented within 10° of each other

Graphic depictions of the OZE are included in Figure 5.1.1, Figure 5.1.2, and Figure 5.1.3:



Figure 5.1.1 OZE relative to dolphin body width

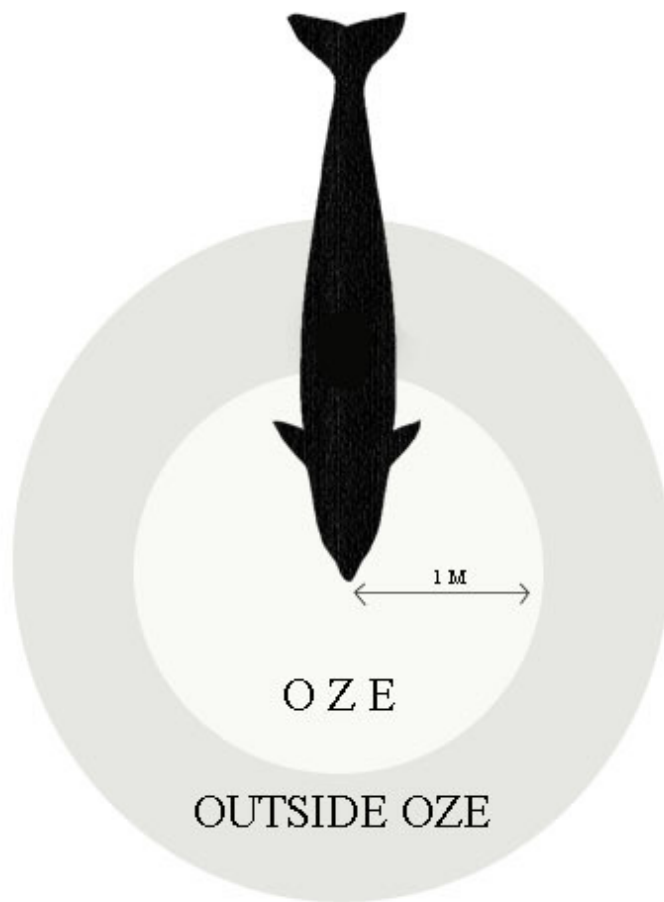

Figure 5.1.2 OZE relative to dolphin length

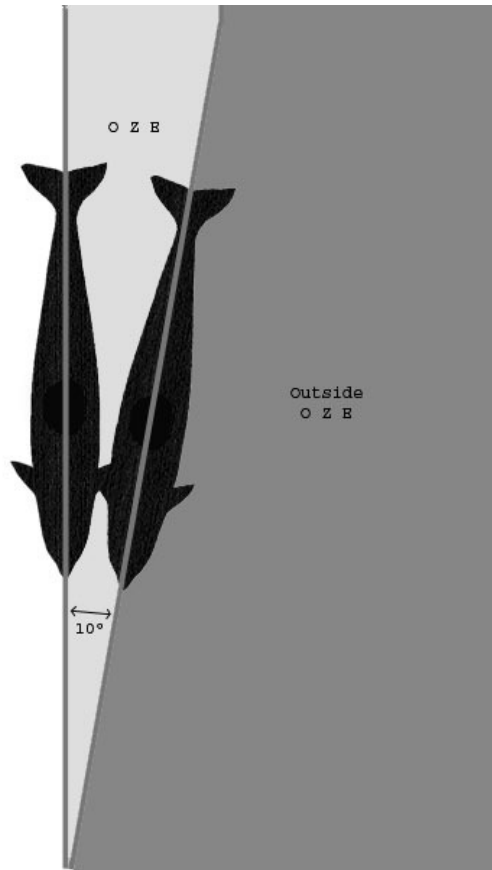

Figure 5.1.3 OZE relative to dolphin head angle

A discussion of the implications of the results described in this chapter, and their relation to the OZE is found in Chapter 6. The relationship between the variables involved in swim position (e.g., distance, head angle, clockface swim position) will be explored in the following sections. A series of analyses were conducted in order to test H2 and H3.

5.2 Distance

An initial series of tests focusing on D2's movement in relation to the OZE was conducted in order to answer the question; does the distance that D2 is positioned away from D1 at the start of the event influence whether or not 1) D2 moves to within 1 m of D1, or 2) D2 remains within 1 m of D1? The value of 1 m is the predicted 'ideal' distance separating dolphins in an echoic eavesdropping scenario (i.e., the OZE). For the 81 episodes where D2 was positioned within 1 m of D1 at the start of the event, D2 remained within the OZE (defined here in terms of distance and not head angle) 61.7% of the time. It may be the case that when D2 is positioned near the 1 m mark, it may be more likely to stray outside the OZE by virtue of its close proximity to the 1 m cutoff point. In order to determine if the distance between the dolphins does in fact predict whether or not D2 swims outside the OZE, a logistic regression model was created. For this model, the dependent variable is; did D2 remain within 1 m of D1, yes or no. The predictor is the distance between the two dolphins at the start of D1's echolocation (i.e., the start of the event). No relationship was found, suggesting that the

distance between the dolphins at the start of the event does not predict whether or not D1 remains within 1 m (Odds Ratio=4.84; df=1; p=0.140).

For the 70 episodes where D2 was outside the OZE (i.e., > 1 m) at the start of the event, D2 moved into the OZE (defined here in terms of distance and not head angle) 31.4% of the time. To test to see if the distance that D2 is positioned away from D1 predicts whether or not D2 crosses into the OZE (i.e., to determine if dolphins swimming close to the border are likely to cross over), a logistic regression model was created. For this model, the dependent variable is; did D2 remain farther away than 1 m from D1, yes or no. The predictor is the distance between the two dolphins at the start of D1's echolocation (i.e., the start of the event). Like the previous model, results suggest that the swim distance does not predict whether or not D2 moves into the OZE (Odds Ratio=1.638; df=1; p=0.205).

To see if there is a difference in the observed swimming behavior in relation to the 1 m cutoff point (i.e., the OZE), a chi-square with Yates' correction was performed. For this test, the number of cases where D2 remained in a space within 1 m or less of D1 (yes, N=50; no, N=31) was compared to the number of cases where D2 remained within a space more than 1 m from D1 (yes, N=48; no, N=22). The difference in the proportion is not significant $\chi^2=0.5$, df=1; p<0.48. Whether or not D2 is positioned inside or outside the OZE does not seem to affect its behavior in terms of remaining in or moving to the OZE (assuming the OZE is found at 1 m). When the OZE was adjusted to a 1.5 meter cutoff point, a logistic regression model produced results much like those for the model for 1 m (does D2 remain within 1.5 m when inside the OZE; Odds Ratio=2.322; df=1, p=0.205; does D2 move to within 1.5 when outside the OZE; Odds Ratio=1.744; df=1, p=0.255). Again, a chi-square with Yates' correction was performed to test to see if there are differences in the proportions of dolphins remaining in the OZE vs. remaining outside the OZE throughout the duration of the echoic eavesdropping episode. The number of cases where D2 remained in a space within 1.5 m or less of D1 (yes N=88, no N=26) was compared to the number of cases where D2 remained within a space more than 1.5 m from D1 (yes N=23, No N=16). The difference in the proportion was weakly significant ($\chi^2=3.97$, df=1; p<0.05). The proportion of dolphins remain in the OZE (at a 1.5 m cutoff) was 0.77; whereas the proportion of dolphins remain outside the OZE was 0.60. The difference in the proportions suggests that D2 is more likely to remain in the OZE when already in the OZE, than D2 is likely to remain outside the OZE when already outside the OZE. Although the distance itself was not a predictor of this movement (as seen in the logistic regression), a difference in behavior between 'ideal eavesdropping zones' does appear to exist for this particular test: it appears that an OZE defined at 1.5 m reveals a very slight tendency for D2 to remain in the OZE more often than it would remain outside of it.

In order to determine if the changes in swimming distance were significantly different across the measured time intervals, a multivariate repeated measures analysis of variance test was conducted. For this test, the data were grouped into two conditions; dolphins inside the OZE at the start of the event (i.e., ≤ 1 m), and dolphins outside the OZE at the start of the event (i.e., >1m). With both conditions

entered into the model, results show that sphericity is violated (Mauchly's $W = 0.003$, $df=20$, $p<0.001$), with Wilks' Lambda revealing a significant interaction between the two conditions (Wilks' $\Lambda = 0.591$, $F(6,28) = 3.23$, $p=0.016$). In order to further explore the nature of this interaction, univariate repeated measures analyses were conducted for each of the two conditions independently. Although these individual tests did not reveal significant interactions on their own (i.e., Wilks' Lambda was not significant), a series of planned contrasts reveal that the difference in means between distance measurements at the start of the event vs. each consecutive time interval moves from non-significant to significant differences in the means. A similar pattern is observed when an independent t-test is conducted comparing the means for each condition at each of the time intervals. Thus, the nature of the interaction observed in the multivariate test appears to be that the two groups (i.e., inside the OZE and outside the OZE), are in fact significantly different to each other in terms of distance measurements at the start of the event, however, after 3 sec, the significant differences between groups is no longer observed, suggesting that each of the groups appears to be reducing the mean distance as time progresses. This interaction is most easily understood by observing the plots in Figure 5.2.1. Dolphins outside the OZE appear to be moving closer together, whereas dolphins in the OZE appear to be moving farther apart over time. The result being that the two groups are 'converging;' on a similar distance measurement as time progresses so much so that the difference between the two groups is no longer significant. Tables showing mean distance measurements for the independent t-tests are found in Table 5.1, with the result of the t-test for each interval found in Table 5.2. Planned contrasts for each of the individual conditions are found in Table 5.3 (inside the OZE) and Table 5.4 (outside the OZE).

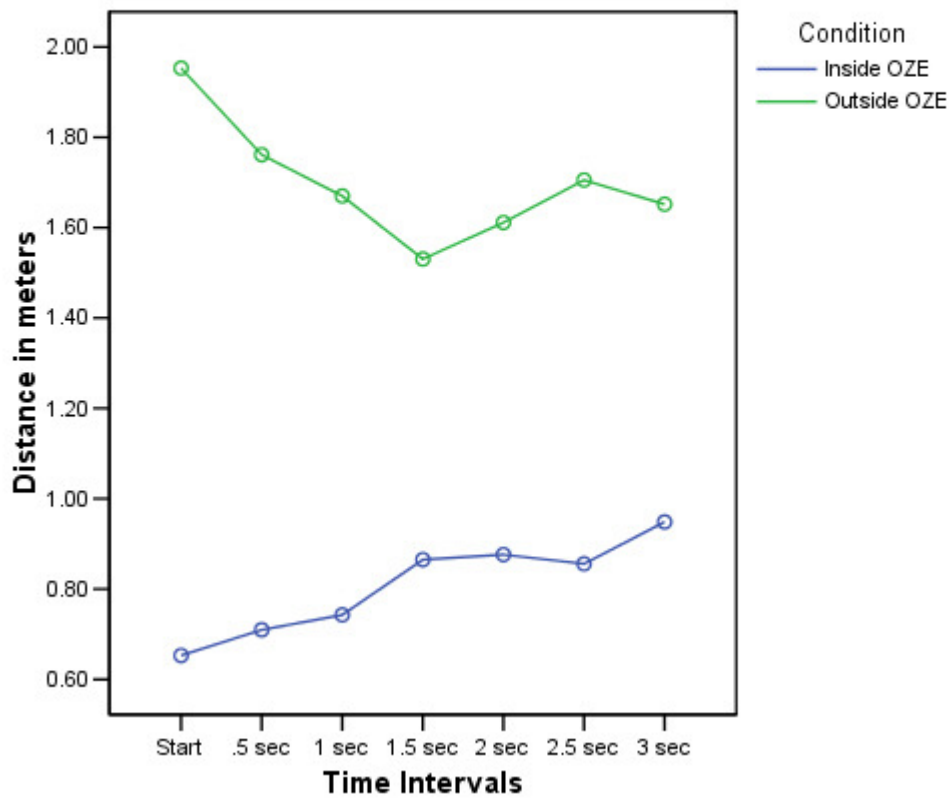

Figure 5.2.1 Plot showing changes in distance for each conditions (inside vs. outside OZE) across time

Table 5.1 Mean distance measurements per time interval for dolphins inside OZE vs. outside OZE defined at 1 m

Time Interval	Condition	N	Mean	Std. Deviation
Distance at start of event	Inside OZE 1 m	83	.6713	.21175
	Outside OZE 1 m	64	1.9327	1.33625
Distance .5 sec	Inside OZE 1 m	81	.7617	.40250
	Outside OZE 1 m	64	1.9565	1.28879
Distance 1 sec	Inside OZE 1 m	77	.8898	.64979
	Outside OZE 1 m	54	2.1092	1.61542
Distance 1.5 sec	Inside OZE 1 m	56	.9079	.47924
	Outside OZE 1 m	37	1.9689	1.63467
Distance at 2 sec	Inside OZE 1 m	38	.9721	.49130
	Outside OZE 1 m	24	1.6203	1.26391
Distance at 2.5 sec	Inside OZE 1 m	29	.9423	.41515
	Outside OZE 1 m	19	1.4655	1.21847
Distance of D1 to D2	Inside OZE 1 m	21	.9486	.38847
	Outside OZE 1 m	14	1.6518	1.60131

Table 5.2 Independent t-test comparing mean distance between dolphins inside and outside OZE at each time interval

Distance at start of event	Equal variances not assumed	t	df	Sig. (2-tailed)
Distance at start of event	Equal variances not assumed	-7.480	65.445	.000
Distance .5 sec	Equal variances not assumed	-7.146	72.744	.000
Distance 1 sec	Equal variances not assumed	-5.257	65.125	.000
Distance 1.5 sec	Equal variances not assumed	-3.841	40.120	.000
Distance 2 sec	Equal variances not assumed	-2.400	27.444	.023
Distance 2.5 sec	Equal variances not assumed	-1.804	20.765	.086
Distance 3 sec	Equal variances not assumed	-1.612	14.026	.129

Table 5.3 Planned contrasts for distance for inside the OZE between start of event and each time interval

Distance	f	Sig.
Start vs. .5 sec	2.496	.130
Start vs. 1 sec	1.926	.180
Start vs. 1.5 sec	9.556	.006
Start vs. 2 sec	7.805	.011
Start vs. 2.5 sec	11.710	.003
Start vs. 3 sec	13.524	.001

Table 5.4 Planned contrasts for distance for outside the OZE between start of event and each time interval

Distance	f	Sig.
Start vs. .5 sec	2.706	.124
Start vs. 1 sec	3.624	.079
Start vs. 1.5 sec	6.108	.028
Start vs. 2 sec	2.171	.164
Start vs. 2.5 sec	.409	.534
Start vs. 3 sec	.393	.541

When the OZE cutoff point is adjusted to 1.5 m, a multivariate repeated measures analysis of variance test does not reveal any significant interaction between the two conditions, and so no planned contrasts or t-tests were conducted. However, when the test is adjusted so that 0.5 sec is used as the start of the event (see section 5.3 for an explanation as to why this control may be of value to this study), with a cutoff point of 1 m, similar results are seen as the initial test: sphericity is violated (Mauchly's $W = 0.014$, $df=14$, $p<0.001$), with Wilks' Lambda revealing a significant interaction between the two conditions (Wilks' $\Lambda = 0.605$, $F(5,29) = 3.79$, $p=0.009$). A similar pattern is seen with both the planned contrasts for each individual condition, and the independent t-tests (i.e., the mean difference between the distance measurements for inside OZE and outside OZE conditions is reduced with time). A plot showing this interaction can be seen in Figure 5.2.2, with the results of the t-tests for each time interval seen in

Table 5.5. When the OZE cutoff point is adjusted to 1.5 m when using 0.5 sec as the start of the event, a multivariate repeated measures analysis of variance test does not reveal any significant interaction between the two conditions, and so no planned contrasts or t-tests were conducted.

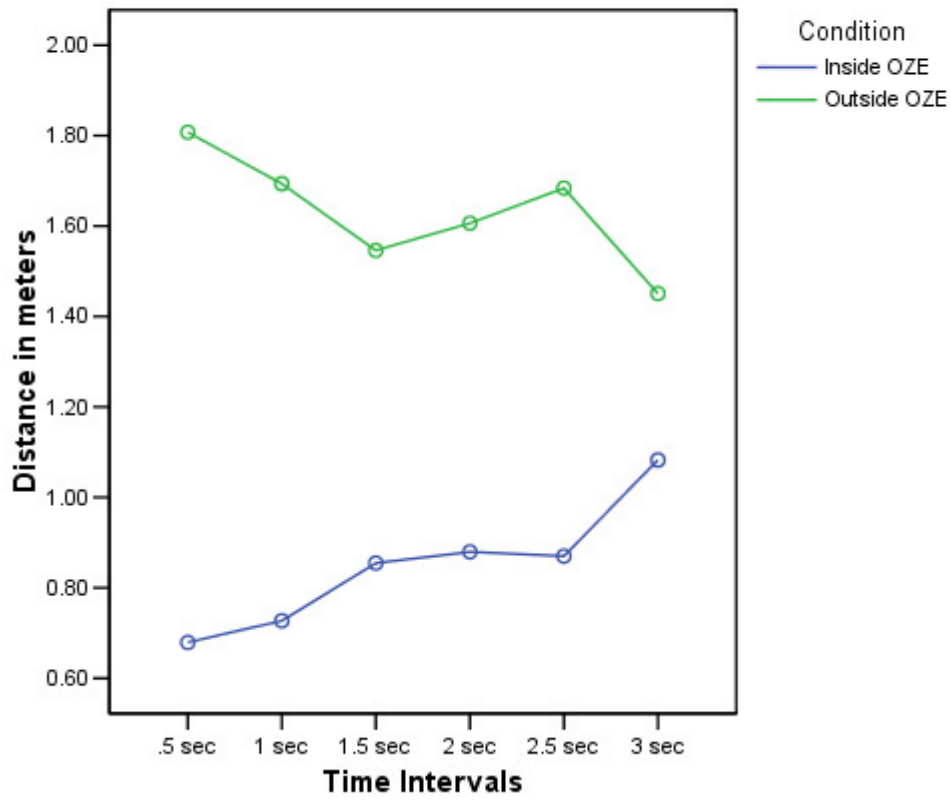

Figure 5.2.2 Plot showing changes in distance for each conditions (inside vs. outside OZE) across time

Table 5.5 Independent t-test comparing mean distance between dolphins inside and outside OZE at each time interval from .5 sec as start of event

Distance at start of event	Equal variances not assumed	t	df	Sig. (2-tailed)
Distance .5 sec	Equal variances not assumed	-9.073	65.155	.000
Distance 1 sec	Equal variances not assumed	-6.855	57.252	.000
Distance 1.5 sec	Equal variances not assumed	-4.563	36.617	.000
Distance 2 sec	Equal variances not assumed	-2.890	24.479	.008
Distance 2.5 sec	Equal variances not assumed	-2.299	19.507	.033
Distance 3 sec	Equal variances not assumed	-.868	17.756	.397

In summary, the chi square test results suggest that dolphins in the OZE (defined at either 1 m or 1.5 m) do not appear to change their behavior to either enter into or remain in the OZE during an eavesdropping episode. The logistic regressions models also suggest that the distance that dolphins are to each other at the start of the event will not predict whether or not they either enter into or remain in the OZE during an eavesdropping episode. The repeated measures tests together with the t-tests reveal that what in fact may be happening is that dolphins, either inside or outside the OZE, appear to be adjusting their swim position across time so that they ultimately obtain a spacing distance between 1 and 1.5 meters during an eavesdropping episode.

5.3 Head angle

An initial series of tests concerning D2's changes in head angle with regards to the OZE were conducted in order to answer the question: does head angle between the 2 dolphins at the start of the event predict whether or not 1) D2 moves his/her head to within a 10° head angle of D1, or 2) D2 remains within a 10° head angle of D1? The angle of 10° is the angle predicted as the 'ideal listening position' for the OZE. For the 10 episodes where head angle was $\leq 10^\circ$ at the start of the event, D2 remained within 10° for 20% of the episodes. It may be the case that when D2's head is positioned within just a few degree of the 10° mark, D2 will be more likely to move its head past 10° by virtue of its close proximity to the 10° cutoff point. In order to determine if this is the case, a logistic regression model was created. This model revealed that head angle at the start of the event is not a predictor of whether or not D2 remains within 10° (Odds Ratio=0.892; df=1; p=0.771).

For the 137 episodes where head angle was $\geq 10^\circ$ at the start of the event, D2 moved to within 10° of D1 24% of the time. As in the previous finding, it may be that case that when D2's head is positioned within just a few degree of the 10° mark, D2 will be more likely to move its head into the 10° area by virtue of its close proximity to the 10° cutoff point. This may in fact be the case. Results of a logistic regression model reveal that head angle at the start of the event is a significant predictor of whether or not D2 moves to within 10° at some point during the eavesdropping episode (Odds Ratio=1.022; df=1; p=0.013).

The mean head angle at the start of the event for those episodes where D2 initiates a 10° head angle is 38.55° (SD=20.46) and the mean for episodes where D2 did not initiate head angle is 54.66° (SD=33.17). A table comparing the central tendency for these two conditions is provided in Table 5.6. This suggests that, on average, the closer two dolphins' heads are together at the start of an echoic eavesdropping episode, the more likely D2 will eventually move to within a 10° head angle of D1. An independent samples t-test reveals that the differences in means is significant ($t(88.49)=-3.339$; $p<0.001$)

Table 5.6 Central tendency for episodes where D2 does and does not initiate 10° head angle

	Initiates 10°	Does not initiate 10°
N	33	104
Mean	38.5506	54.6593
Std. Error of Mean	3.56233	3.25280
Median	35.0000	47.0000
Mode	18.00(a)	15.00(a)
Std. Deviation	20.46403	33.17221
Variance	418.776	1100.396

a Multiple modes exist. The smallest value is shown

A second series of logistic regression models were created to discover if head angle between the 2 dolphins at the start of the event predicts whether or not 1) D2 moves his/her head to within a 30° of D1, or 2) D2 remains within a 30° of D1. For this series, the definition of the OZE as it pertains to head angle has been expanded to the angle of 30° . Results here are similar to the model for 10° ; head angle at the start of the event is not a predictor of whether or not D2 remains within 30° (Odds Ratio=1.011; df=1; p=0.776). However it is a significant predictor of whether or not D2 moves to within 30° at some point during the eavesdropping episode (Odds Ratio=1.039; df=1; p<0.001). The mean head angle at the start of the event for those episodes where D2 initiates a 30° head angle is 50.77° , and the mean for episodes where D2 did not initiate head angle is 76.89° . An independent samples t-test reveals that the differences in means is significant ($t(95)=-4.778$; $p<0.001$). Like the test for 10° , this suggests that, on average, the closer two dolphins' heads are together at the start of an

echoic eavesdropping episode, the more likely D2 will eventually move to within a 30° head angle of D1.

In order to determine if the changes in head angle were significantly different across the measured time intervals, a repeated measures analysis of variance was conducted for all measured head angles at all time intervals. Results indicate that no significant differences between the measured time intervals exist for a univariate analysis where sphericity is violated (Mauchly's $W = 0.239$, $df=20$, $p=0.001$). However, a multivariate test reveals significant differences between the measured time intervals (Wilks' $\Lambda = 0.501$, $F(6,29) = 4.815$, $p=0.002$).

Following from the results of the multivariate repeated measures analysis, a series of paired t-tests were conducted in order to determine whether there is a significant relationship between the means of dolphins' head angles at the start of the event vs. various time intervals throughout the eavesdropping episode. Significant differences in the means was only seen for the pair 'start of event vs. 3 sec' ($t(34)=4.322$; $p<0.001$). For this pair, the mean head angle at the start was 44.32° and at 3 sec was 29.16°, with a mean difference of 15.16° ($SD=20.06$). All other pairings for time intervals revealed no significant differences in the means. When the same series of t-tests was conducted only on dolphins within the OZE (i.e., 10° or less), significant differences in the means were found for 'start vs. 0.5 sec' ($t(6)=-2.568$; $p<0.05$), 'start vs. 1 sec' ($t(6)=-3.011$; $p<0.02$), and 'start vs. 1.5 sec' ($t(5)=-3.808$; $p<0.01$). Differences in means were 'start (mean=6.89°) vs. 0.5 sec (mean=25.99°)', 'start (mean=6.89°) vs. 1 sec (mean=24.20°)', and 'start (mean=6.83°) vs. 1.5 sec (mean=30.17°)'. A plot showing all time intervals is seen in Figure 5.3.1. This suggest that for the first three 0.5 sec intervals after the start of the event, the difference in head angles shows a significant *increase* in head angle.

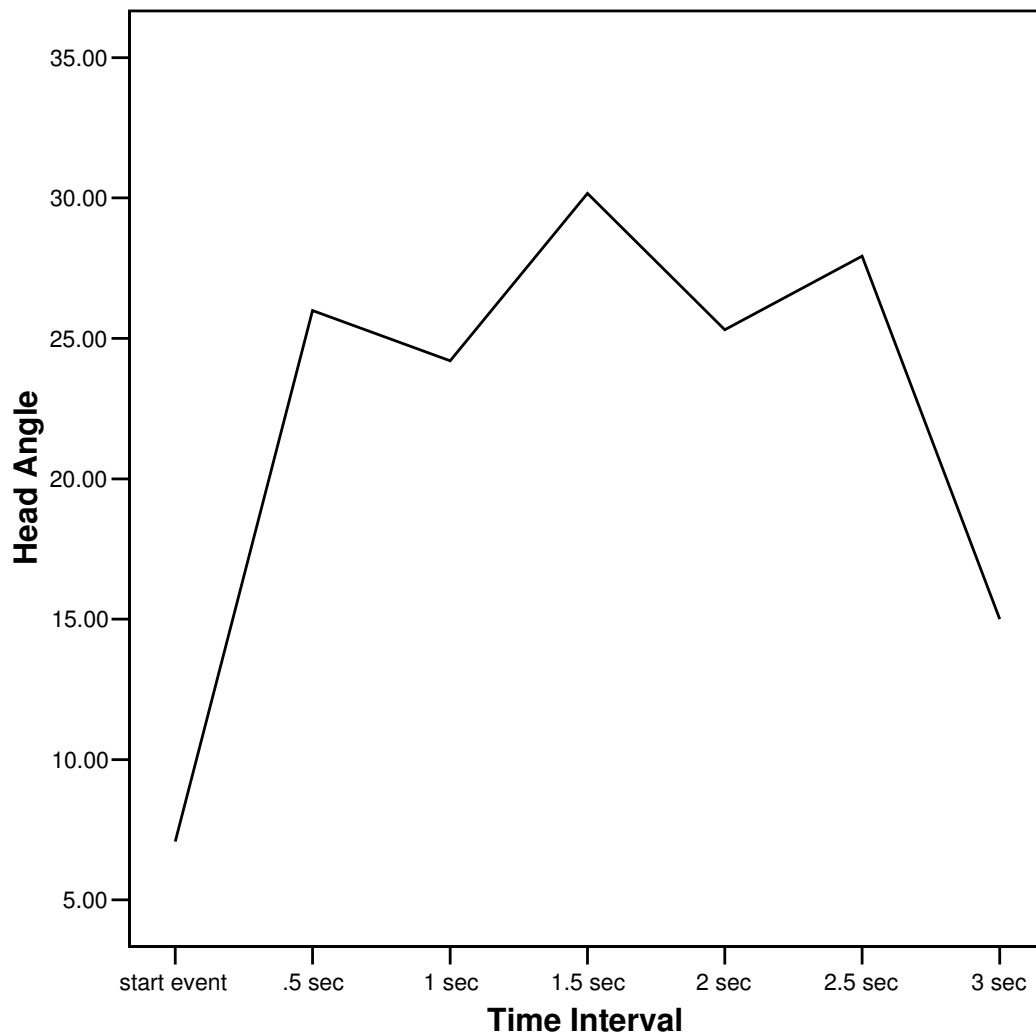

Figure 5.3.1 Plot of changes in mean head angle across time for dolphins inside the OZE (OZE at 10°)

This plot suggests that there is a significant tendency for D2 to turn away from D1 (i.e., increase head angle) after the start of the event for those episode where they start with head angles 10° or less; this is not predicted by the echoic eavesdropping hypothesis, and in fact seems a very strange observation. This can, however, be explained by the fact that at the start of the event, D1 is facing in the direction of the camera only 65.6% of the time, meaning that dolphins (D1) engage(s) echolocation on the camera when facing away from the camera in more than one third of recorded episodes (34.4% of the time). After 0.5 sec, D1 is facing the camera 91.6% of the time. This reveals that D1 will turn to look at the camera during the first 0.5 sec after engaging echolocation for those episodes where he/she is not already facing the camera. This explain why it appears that D2 ‘turns away’ from D1 in the above plot – what is in fact depicted here is D2 remaining in the same position while D1 turns to look at the camera. That is, the angle measurements at the ‘start of the event’ are then biasing the results of the above tests due to the fact that in 34.4% of episodes, D1 is not yet facing the camera. When a paired t-test is conducted using the ‘0.5 sec’ time interval as the ‘start of the event’ for the pair (as opposed to

the actual 'start of event' time interval) for dolphins in the OZE (e.g., 0.5 sec vs. 1 sec), significant is seen for the pairs '0.5 vs. 2 sec' sec' ($t(63)=2.540$; $p<0.01$), and 0.5 vs. 3 sec' ($t(35)=3.962$; $p<0.001$). A plot of the changes in mean head angle using .5 sec as the starting point (for dolphins in the OZE) is seen in Figure 5.3.2. At 2 sec (where significant differences were seen), D2 appears to increase head angle, and at 3 sec (also where significant differences were seen) D2 appears to decrease head angle. This plot does not appear to show any clear relationship for D2's head angle in terms of moving closer to or farther away for D1 overall. A Bonferroni correction suggesting that significance is only achieved at 0.008 indicates that the pair '0.5 vs. 2 sec' sec' ($t(63)=2.540$; $p<0.01$) may in fact be a spurious result. Controlling for the 'D1 turn toward camera time delay' bias has effectively eliminated the significant differences in means that is otherwise observed when using 'start of event' as the start of the event, and no longer suggests that D2 is 'turning away' from D1 during the eavesdropping episode. This is more in line with the results of the initial logistic regression showing that head angle was not a predictor of whether or not D2 maintained head alignment.

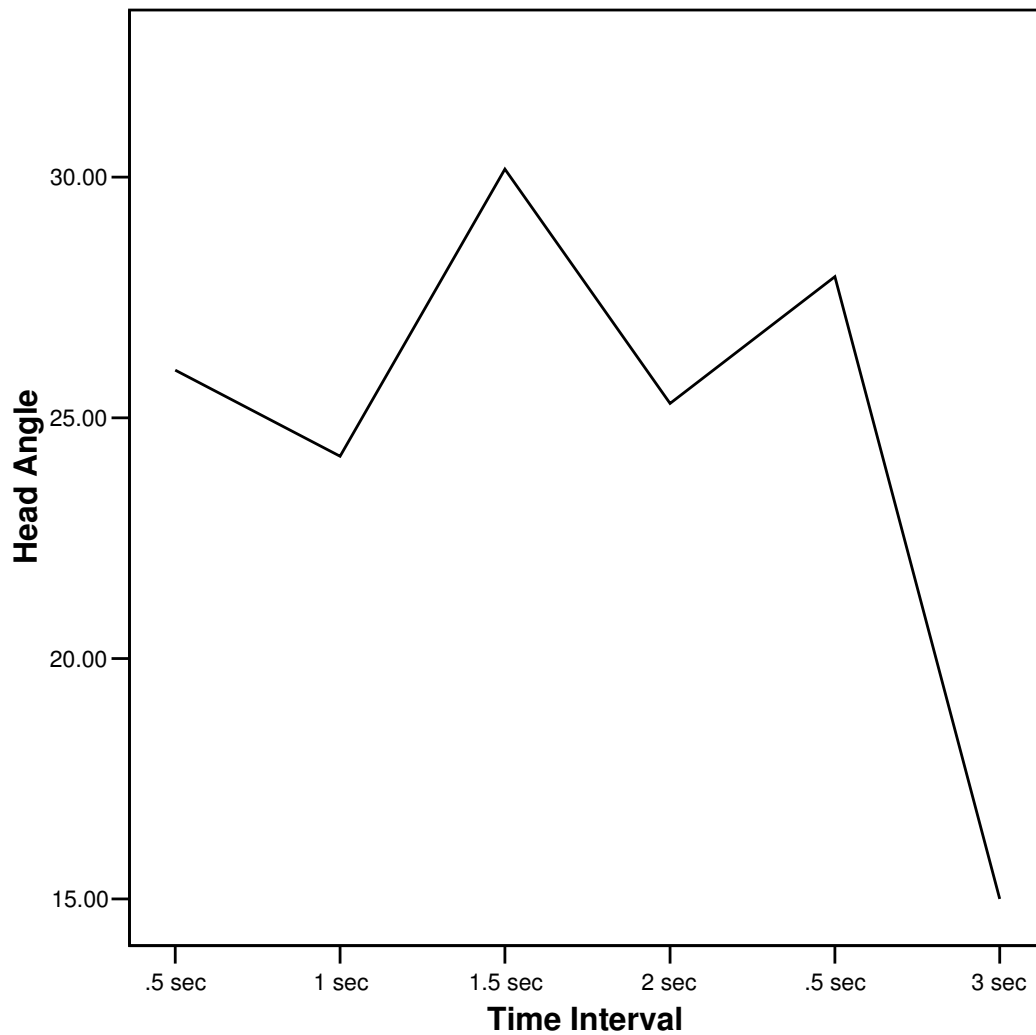

Figure 5.3.2 Plot of changes in mean head angle across time for dolphins inside the OZE (OZE at 10°) – starting at ‘.5 sec’ instead of ‘start of event’

Given this important discovery concerning the time delay between D1’s engaging echolocation and D1’s turn to face the camera (a 0.5 second delay), and how this delay appears to bias the results, a repeated measures analysis of variance for unconstrained angle measurements (i.e., for all measurements and not just those $\leq 10^\circ$) was re-run for all time intervals, but this time eliminating the ‘start of event’ data. As was expected, results indicate significant differences between the measured time intervals. For a univariate analysis where sphericity is not violated (Mauchly’s $W = 0.522$, $df=14$, $p=0.089$), we find significant within-subject effects ($F=4.561$, $df=5$, $p<0.001$). A multivariate test also reveals significant differences between the measured time intervals (Wilks’ $\Lambda = 0.577$, $F(5,31) = 4.542$, $p=0.003$). The initial paired t-test series for unconstrained head angles was then re-run, this time using ‘.5 sec’ in the pair as opposed to ‘start event’. With this control in place, significant differences in the means were found for two pairs: ‘0.5 sec vs. 2 sec ($t(63)=2.54$; $p<0.01$), and ‘0.5 sec

vs. 3 sec' ($t(35)=3.962$; $p<0.001$). A plot of changes in mean head angle over the various time intervals is presented in Figure 5.3.3. Although significant differences in the means were only found for 2 sec and 3 sec, this plot clearly shows a tendency for D2 to decrease the head angle to D1 throughout the course of the eavesdropping episode, and this change is significant according to the repeated measures tests.

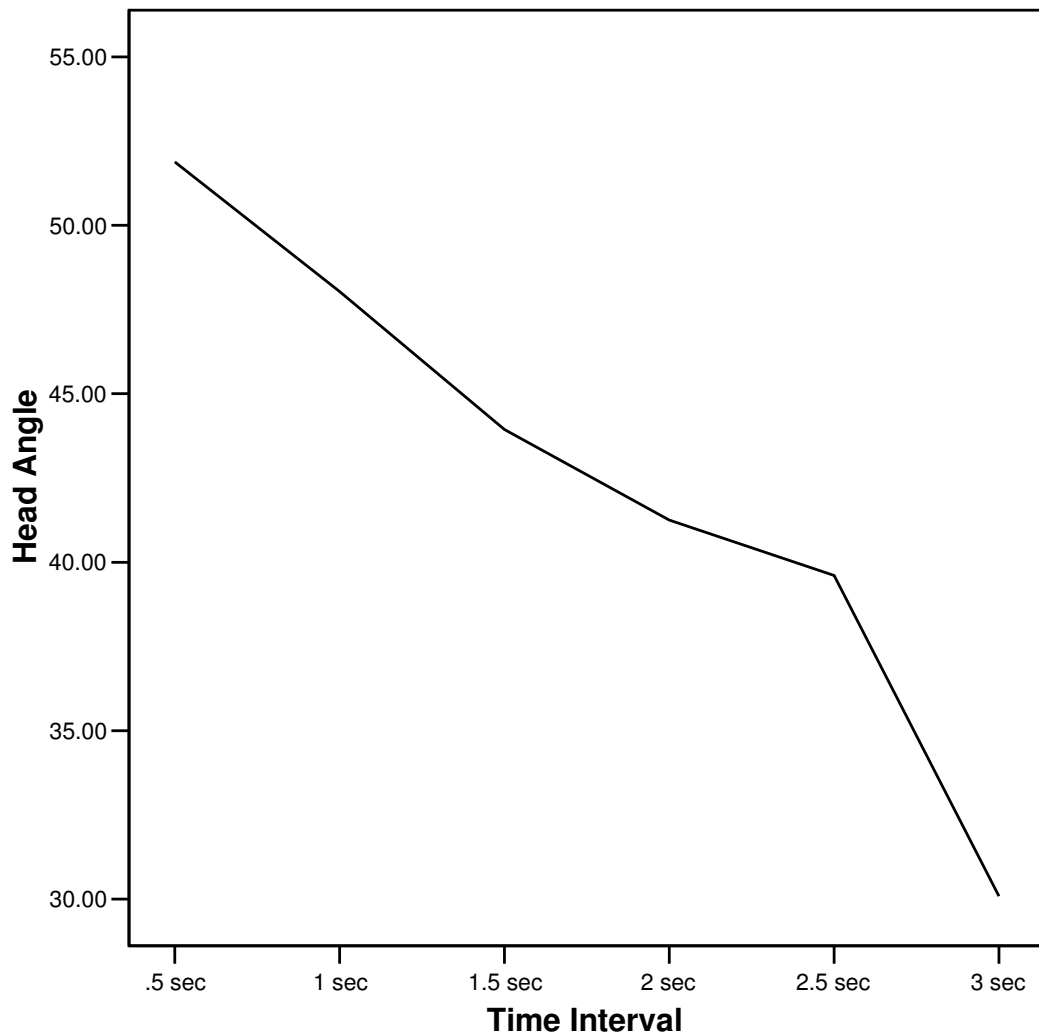

Figure 5.3.3 Plot of changes in mean head angle across time for all dolphins– starting at ‘.5 sec’ instead of ‘start of event’

When a paired t-test is conducted only for episodes where D2 is outside the OZE (i.e., $>10^\circ$), a significant difference in the means was only found for the pair ‘start (mean=45.37, SD=22.39) vs. 3 sec (mean=29.57, SD=19.72) ($t(33)=4.441$; $p<0.001$). However, when the test is controlled for the 0.5 sec delay it takes D1 to turn toward the camera, and the t-test is re-run for pairs where 0.5 is used in each pair, significant differences in the means was found in the pairs ‘0.5 vs. 2 sec’ ($t(57)=2.450$; $p<0.02$), and 0.5 vs. 3 sec ($t(33)=3.918$; $p<0.001$). A plot of the changes in mean head angles for this control group for dolphins outside the OZE is seen in fig Figure 5.3.4. Like the plot for ‘all dolphins’,

this plot for dolphins outside the OZE suggests that D2 decreases head angle throughout the duration of the eavesdropping episode. It should be noted here that a Bonferroni correction (with significance only at 0.008) eliminates all significant differences in the paired t-tests described above except for those between 0.5 sec and 3 sec.

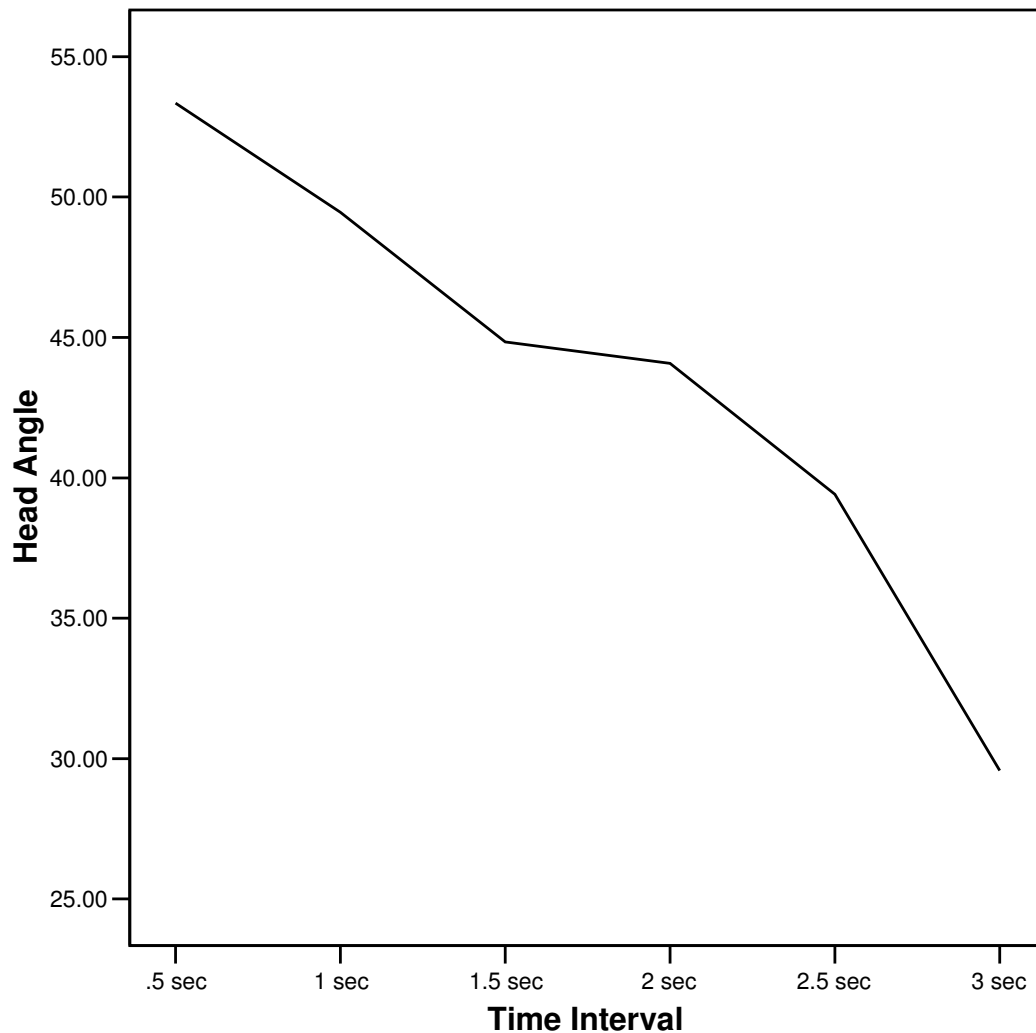

Figure 5.3.4 Plot of changes in mean head angle across time for dolphins outside the OZE starting at '0.5 sec' instead of 'start of event'

When the initial logistic regression tests were re-run, this time controlling for the 0.5 sec delay, and using the 0.5 sec head angle measurement as the predictor of whether or not D2 maintains or initiates a head angle within the OZE (for both a 10° and a 30° OZE), the results of the tests were similar to those of the first series, but with one important difference. As in the first series, the head angle between the dolphins at both the start of the event, and at 0.5 sec were both significant predictors of whether or not D2 would move to an angle within the OZE if outside the OZE. Also, like the first series, the head angle of the dolphins at 0.5 sec was not a significant predictor of whether or D2 would remain in the OZE if already positioned in the OZE at 10°. But, unlike the first series, the 0.5 sec head

angle was a predictor of whether or not D2 would maintain head angle within the OZE if the OZE is defined as a 30° angle (Odds Ratio=1.11; df=1; p=0.002). An independent sample t-test confirms that the mean difference in head angle at 0.5 sec for those episodes where D2 remained in the OZE (mean=15.90, SD=15.28) is significantly different to the mean difference in head angle at 0.5 sec for those episodes where D2 did not remain in the OZE (mean=35.05, SD=14.52) ($t(48)=4.037$; $p<0.001$). This suggests that the closer the angle between dolphins at .5 sec, the more likely D2 will maintain head alignment in the OZE (at 30°).

To test if there is a difference in swimming behavior in relation to the 10° cutoff point (i.e., the OZE), a Fisher's exact test (2-tailed) was performed (Fisher as opposed to a chi-square with Yates' correction due to small sample size). For this test, the number of cases where the head angle between dolphins remained at 10° or less from the start of the event onwards (yes, N=2; no, N=7) was compared to the number of cases where the head angle between dolphins remained at more than 10° from the start of the event onwards (yes, N=109; no, N=35). The difference in the proportion is highly significant ($p<0.002$). This suggests that the difference in behaviors between zones (i.e., inside the OZE vs. outside the OZE) is significant: when D2 is positioned in the OZE, D2 is likely to leave the OZE, and when positioned outside the OZE, D2 is likely to enter the OZE (assuming the OZE is found at 10° head angle). When the 'start of the event' variable was adjusted so as to start at 0.5 seconds into the event (in order to control for potential bias as described previously), the number of cases where the head angle between dolphins remained at 10° or less from the start of the event onwards (yes, N=3; no, N=7) was compared to the number of cases where the head angle between dolphins remained at more than 10° from the start of the event onwards (yes, N=112; no, N=31). The difference in the proportion is significant ($p<0.002$), as in the first test. When the OZE was adjusted to a 30° head angle cutoff point, a chi-square with Yates' correction was performed to test to see if there are differences in the proportions of dolphins remaining in the OZE vs. remaining outside the OZE from the start of the event onwards. The number of cases where the dolphins' heads remained within 30° or less (yes N=12, no N=36) was compared to the number of cases where the dolphins heads remained above 30° (yes N=49, No N=51). The difference in the proportion was significant ($p<0.009$), which suggests that D2 is more likely to move to within the OZE when positioned outside the OZE than D2 is likely to remain in the OZE. However, adjusting the start of event to the 0.5 second time interval (as in the last test) produces different results. The number of cases where the dolphins heads remained within 30° or less was (yes N=18, no N=20). The number of cases where the dolphins heads remained above 30° was (yes N=61, No N=49). The difference in the proportion was not significant ($p<0.112$). At the 0.5 sec starting point, D1 is more often facing the camera (given the delay bias) – the difference in the proportions (0.9 for in the OZE and 1.24 for outside the OZE) suggest that once in a position where D1 is facing the camera and engaging echolocation, D2 is no more likely to remain either inside or outside the OZE when the OZE is defined as 30°.

5.4 Testing the OZE: head angle and distance combined

Having considered both head angle and distance separately in relation to the OZE, it is now possible to combine the two in order to address all described parameters of the OZE (see section 5.1). The OZE consists of both a head angle of 10° or less, and a distance between rostrum tips of 1 m or less. Hypotheses H2 and H3 suggest that D2 will remain in the OZE or move into the OZE during an eavesdropping scenario. For a direct test of both hypotheses, a chi-square was performed, comparing the proportion of instances where D2 remained in the OZE with those instances where D2 remained outside the OZE. The number of instances where D2 remained inside the OZE (as defined above) throughout the duration of the episode was $N=0$, and the number of instances where D2 started in the OZE but moved out of the OZE is $N=7$. When this is compared to the number of instances where D2 remained outside the OZE throughout the duration of the episodes ($N=41$), and the number of instances where D2 did not remain outside the OZE (i.e., moved into the OZE) when originally positioned outside the OZE ($N=26$), the difference in proportions is significant for the Fisher's exact test (2-tailed) ($p<0.002$). This suggests that D2's behavior when inside the OZE as opposed to outside the OZE is significantly different – D2 appears to move out of the OZE when starting in it, and into the OZE when starting outside it. This is somewhat paradoxical and may again be related to the 0.5 second delay in D1 focusing on the camera after engaging echolocation which causes a 'jump' in the head angle between the start of the event and 0.5 sec into the event. When this is controlled for, and the 0.5 second time interval is used as the 'start of the event', the number of instances where D2 remained inside the OZE (as defined above) throughout the duration of the episode was $N=3$, and the number of instances where D2 started in the OZE but moved out of the OZE is $N=5$. When this is compared to the number of instances where D2 remained outside the OZE throughout the duration of the episodes ($N=37$), and the number of instances where D2 did not remain outside the OZE (i.e., moved into the OZE) when originally positioned outside the OZE ($N=20$), the difference in proportions is not significant for the Fisher's exact test (2-tailed) ($p<0.24$). This control eliminates the paradox, and also suggests that behavior between dolphins positioned in or outside the OZE at the start of the event (at 0.5 sec) is not significantly different (i.e., that there is no appreciable tendency to move between zones).

Interestingly, the actual percentage of episodes where D2 is inside the OZE at the start of the episode when compared to all episodes for Data Set 2 is 4%. The percentage of dolphins remaining inside the OZE (when measuring from 'start of event') is 0%, and when measuring from '0.5 sec' is just 2%. As a general observation, it is very rare for a dolphin to both be found in and remain in the OZE for this study.

Given the rarity of this event, a second series of tests were conducted to test other combinations of the OZE for significant differences in behaviors between positions inside and outside of the OZE. The OZE was redefined with three difference sets of parameters: 1) rostrums ≤ 1 m apart and head angle of $\leq 30^\circ$, 2) rostrums ≤ 1.5 m apart and head angle of $\leq 10^\circ$, and 3) rostrums ≤ 1.5 meters apart and head

angle of $\leq 30^\circ$. The results of these tests using ‘start of event’ as the start of the event is found in Table 5.7 and when using ‘0.5 sec’ as start of event (in order to control for potential bias) are found in Table 5.8.

Table 5.7 Chi-square testing D2 inside and outside the OZE at ‘start of event’

OZE definition	Yates χ^2 Value	Asymp. Sig. (2-sided)	df	Proportion remain in OZE	Proportion remain outside OZE
1 m and 30°	13.06	p<0.001	1	.13	.41
1.5 m and 10°	0.28*	p<0.07	1	.13	.49
1.5 m and 30°	6.81	p<0.01	1	.20	.52

* Fisher’s exact test calculated due to sample size

Table 5.8 Chi-square testing D2 inside and outside the OZE at ‘.5 sec’ used as start of event

OZE definition	Yates χ^2 Value	Asymp. Sig. (2-sided)	df	Proportion remain in OZE	Proportion remain outside OZE
1 m and 30°	1.86	p<0.17	1	.35	.54
1.5 m and 10°	1.14	p<0.29	1	.43	.72
1.5 m and 30°	1.61	p<0.2	1	1	.69

As in the first test, the second series of combinations of parameters for the OZE did not reveal any significant differences between proportions when the 0.5 sec start of event was controlled for. Significant differences in the proportions were seen for both tests where the OZE had a 30° when measured at using the ‘start of event’ time interval, which may have biased the results. The overall conclusion here is that D2’s behavior in terms of remaining in/outside or moving to/from the OZE is no different depending on a starting position either inside or outside the OZE. As a result, D2 is just as likely to remain in the OZE as remain outside the OZE during an eavesdropping event, a finding that could allow us to accept the null hypothesis.

5.5 Exploring relationships between variables

5.5.1 Distance and head angle

In order to further explore relationships between variables, a series of tests were conducted in answer to specific questions. First, does the head angle at the start of the event predict whether or not D2 moves to within 1m of D1 during the event? Following from a logistic regression model, head angle was not a predictor (Odds Ratio=1.015; df=1; p=0.086). When ‘0.5 sec’ was used as the start of event,

head angle was not a predictor (Odds Ratio=1.007 df=1; p=0.390). For the question; does head angle at the start of the event predict whether or not D2 will remain within 1 m? Following from a logistic regression model, head angle was not a predictor (Odds Ratio=1.004; df=1; p=0.697). When '0.5 sec' was used as the start of event, head angle was not a predictor (Odds Ratio=1.008, df=1; p=0.35). This is expected given the above findings concerning D2's movements with regards to the OZE.

A series of tests were performed to explore the relationship between head angle, distance and whether or not D2 'shifted' its head to look at the camera. The variable 'did D2 shift' records a binary yes/no answer in answer to the question; did D2, at some point during the episode, turn to face the camera 'head on' (i.e., with rostrum pointing toward the camera) from a position where he/she was facing away from the camera. Results were similar to the test series investigating 'did D2 echolocate' in relation to distance and head angles variables at various time intervals. Given that these two variables are closely correlated (Pearson's R: $r_{158}=0.688$, $p<0.001$), this is not surprising. Following from a logistic regression model, distance at the start of the event was not a predictor of whether or not D2 shifted toward the camera (Odds Ratio=1.569; df=1; p=0.072). However, head angle at both the start of the event and at 0.5 sec was a significant predictor of whether or not D2 shifted (start event: Odds Ratio=1.014; df=1; p=0.019 and at 0.5 sec: Odds Ratio=1.018; df=1; p=0.004). An independent t-test revealed that the farther apart the two dolphins' heads, the less likely D2 would shift (start event: $t(139)=-2.234$; $p<0.016$ and 0.5 sec: $t(568)=2.827$; $p<0.006$). The differences in means for the start of the event were yes shift=41.35°, no shift=57.14°, and for 0.5 sec; yes shift=43.67°, no shift=59.81°.

5.5.2 Clockface swimming position

A series of logistic regression tests were performed to answer the questions concerning if clockface swimming position at the start of the event (and at 0.5 sec) was a predictor of whether or not 1) D2 stays within 1m of D1, 2) D2 moves to within 1m of D1, 3) D2 initiates head alignment (both 10° and 30°) with D1, and 4) D2 maintains head alignment (both 10° and 30°) with D1. None of these models revealed that clockface swim position is a predictor of any of these behaviors.

Despite clockface swimming position not being a predictor of D2's behaviors in relation to the OZE, it is interesting to note the preference for swimming positions that seems to occur for D2. The frequency with which D2 is found in various clockface positions for all recorded episodes is found in Figure 5.5.1

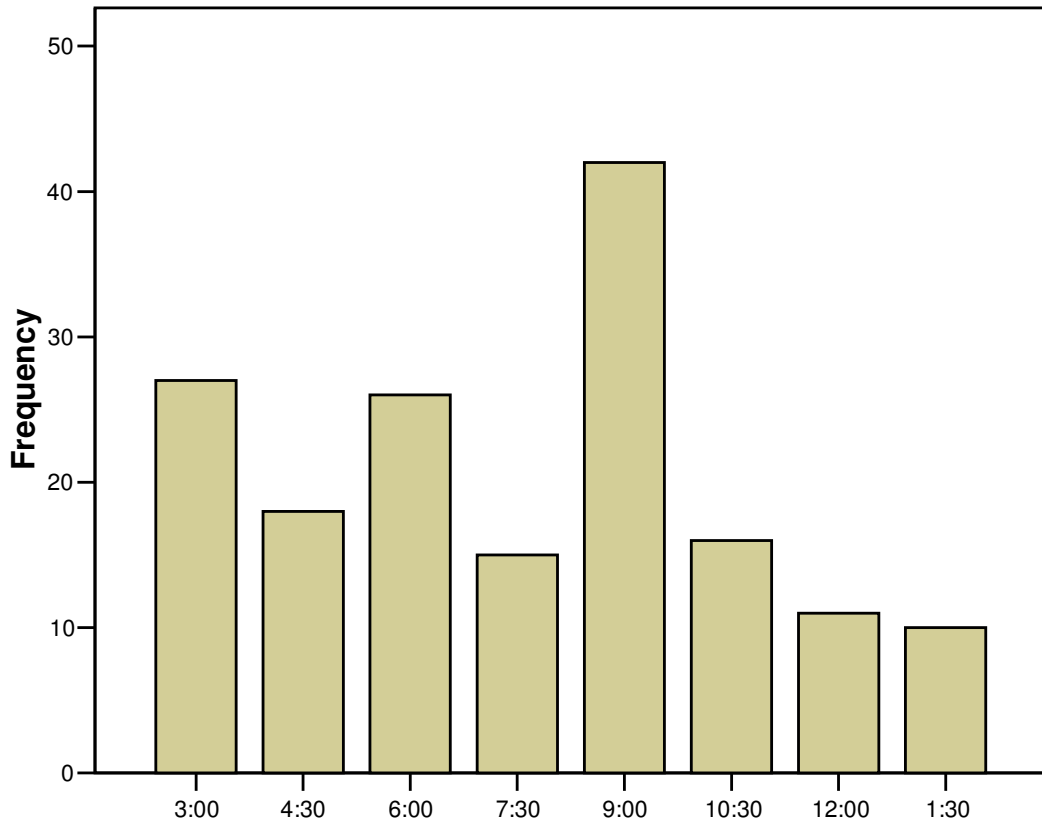

Figure 5.5.1 Frequency of clockface swimming position for D2 at start of event

It would be expected that clockface swimming position would be evenly distributed across positions (if dolphins swim in random clockface positions), but this figure shows that D2 is found at 9:00 more than twice as often as the other positions. A chi-square using these frequencies vs. the expected distribution reveals significant difference in the proportions ($\chi^2=17.03$, $df=7$; $p<0.025$) (3:00, $N=27$; 4:30, $N=18$; 6:00, $N=26$; 7:30, $N=15$; 9:00, $N=42$; 10:30, $N=16$; 12:00, $N=11$; 1:30, $N=10$). The expected frequency per positions is 20.625. The observed frequency is not consistent across time intervals; 9:00 is always more than twice as frequencies observed as most other positions.

It was previously shown that clockface swimming position was not a predictor of whether or not D2 echolocated or remained silent, which makes this observation a bit curious. A series of logistic regression tests were performed to determine if clockface swim position was a predictor of whether or not D2 could be found in the OZE (in terms of head angle and distance). Tests were conducted for clockface position in relation to D2 at ≤ 1 m at the start of the event, and at 0.5 sec; D2 at ≤ 1.5 m at the start of the event and 0.5 sec; head angle $\leq 10^\circ$ at start of the event and 0.5 sec; head angle $\leq 30^\circ$ at start of event and 0.5 sec. For all of these conditions, clockface swimming position was not a significant predictor of the swim position of D2 in relation to the OZE.

A logistic regression was performed to see if a clockface swim position is a predictor of whether or

not D2 can be found inside the OZE if the OZE is defined using a combination of distance and head angle (for this example, $\leq 1.5\text{m}$ and $\leq 30^\circ$). The model did not find that swim position was a significant predictor. When looking at the frequency with which dolphins are found in various clockface swim positions during those episodes where they are in the OZE ($\leq 1.5\text{m}$ and $\leq 30^\circ$) at 0.5 sec after the start of the event (Figure 5.5.2), and those episodes where they are outside the OZE at 0.5 sec after the start of the event (Figure 5.5.3), we again see a preference for dolphins in the 9:00 position, but also for the 3:00 position. A chi-square with Yates' correction found significant differences in the proportions for both of these conditions (inside OZE: $\chi^2=32.88$, $df=7$; $p<0.001$, and outside OZE: $\chi^2=62.33$, $df=7$; $p<0.001$). The preference for positions at 3:00 and 9:00 (when in the OZE) may simply be an indication that dolphins prefer to swim on a horizontal plane when traveling as a dyad in general; a position that likely facilitates pectoral fin contact, as well as visual contact, and is not necessarily related to eavesdropping (as implicated in the lack of significant differences in the proportions found for the previous series of tests). High relative frequency is also seen for the 6:00 swim position for dolphins outside the OZE, a swim position that is commonly seen between mothers and juveniles/calves, and (again) may be an indication for swim position preference in general and not swim position preference as it relates to behaviors associated with echoic eavesdropping.

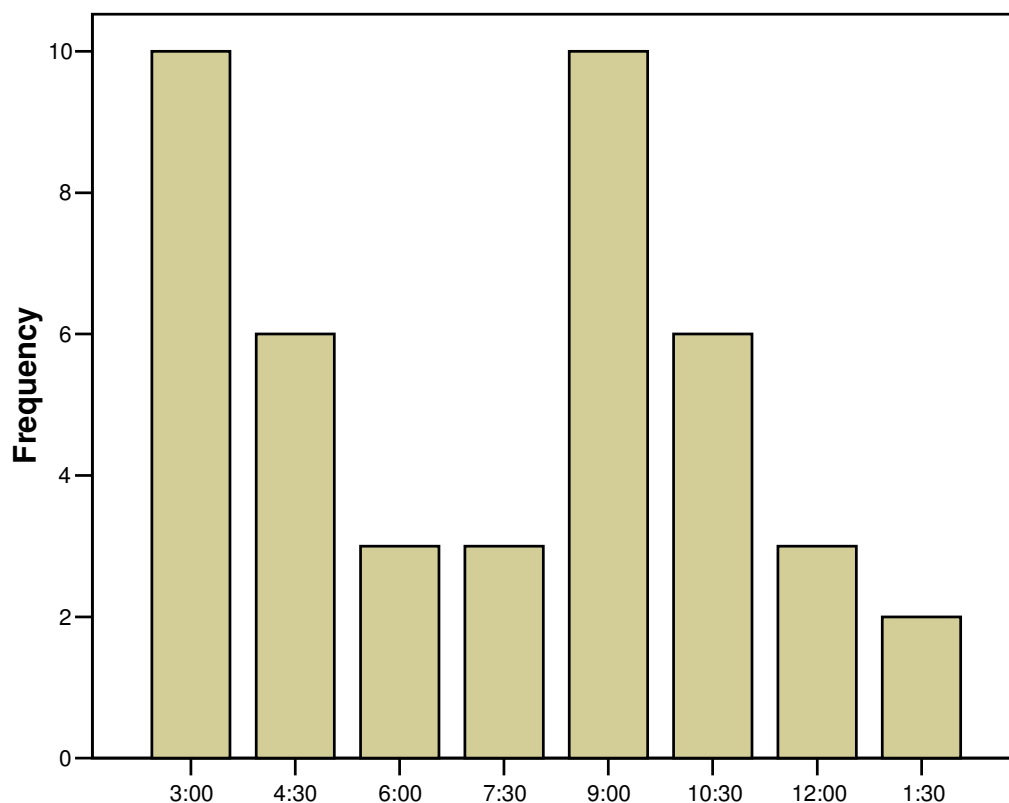

Figure 5.5.2 Clockface swimming position for D2 in the OZE at .5 sec

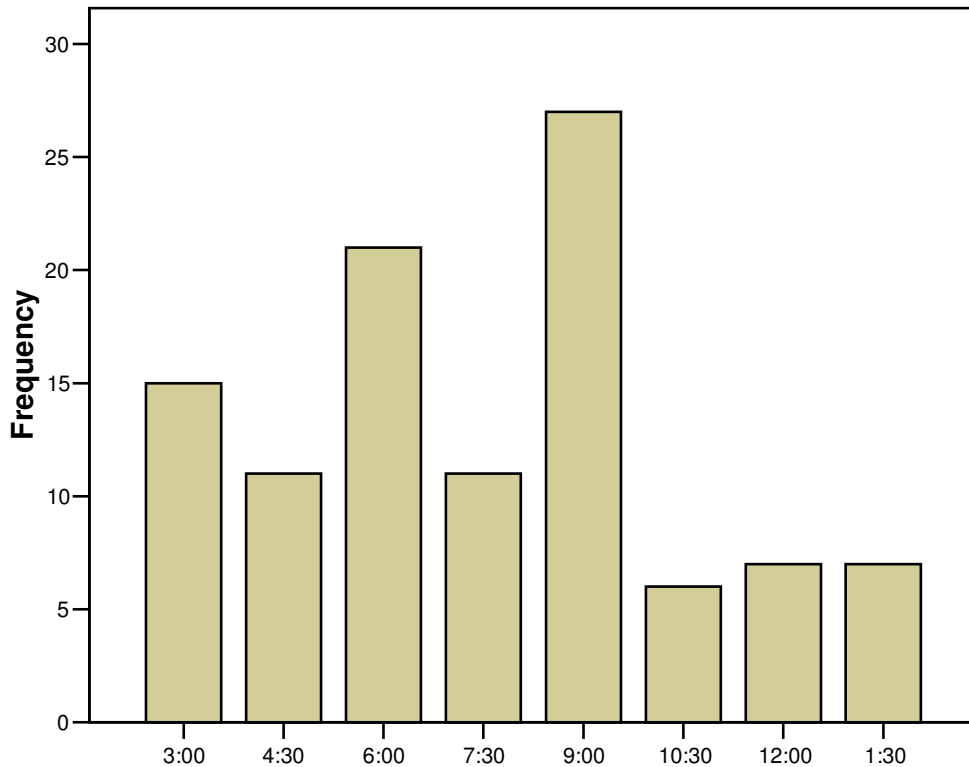

Figure 5.5.3 Clockface swimming position for D2 outside the OZE at .5 sec

5.5.3 Click train length

A series of logistic regression tests were performed to answer the question; can the length of D1's click train predict whether or not D2 moves to or remains within 1 m of D1. For these tests, the binary dependent variable was did D2 move to (or remain) within 1 m (yes, no), and the independent variable was the length of D1's click train. Results for each condition are as follows: D2 move to within 1 m measured from start of event (Odds Ratio=0.646; df=1; p=0.011). D2 move to within 1 m measured from 0.5 sec (Odds Ratio=0.678; df=1; p=0.043). D2 remains within 1m of D1 measured from start of event (Odds Ratio=1.322; df=1; p=0.055). D2 remains within 1 m of D1 measured from 0.5 sec (Odds Ratio=1.342; df=1; p=0.031). Thus, for 3 conditions, the length of D1's click train was a predictor of D2's behavior in relation to movement to or within the OZE. To further explore these relationships, independent sample t-tests were conducted – the results of each condition where the mean length of the click train was compared between yes and no responses were as follows: D2 move to within 1 m measured from start of event ($t(568)=2.827$; $p<0.006$) (Yes, mean length = 2.84 sec; No, mean length = 1.71 sec). D2 move to within 1 m measured from 0.5 sec ($t(60)=2.158$; $p<0.035$) (Yes, mean length = 2.60 sec; No, mean length = 1.73 sec). D2 remains within 1m of D1 measured from start of event ($t(82)=-2.311$; $p<0.023$) (Yes, mean length = 1.99 sec; No, mean length = 2.67 sec). D2 remains within 1m of D1 measured from 0.5 sec ($t(79)=-3.808$; $p<0.01$) (Yes, mean length = 1.92 sec; No, mean length = 2.83 sec). These results suggest that the longer the click train length, the more likely

D2 is to move to within 1 m of D1 during the episode in which D2 is farther away than 1 m. Also, the longer the click train length, the less likely D2 is to stay within 1 m of D1. It is possible here that these relationships may be describing the fact that a longer click train from D1 means a longer overall episode length, and therefore a larger chance that D2 will, by chance, make movements closer to or farther away from D1. This would explain why longer click trains appear to be ‘causing’ D2 to move away from D1 in those instances where he/she is closer than 1 m, and closer to D1 in those instances where D2 is farther than 1 m. That is, these significant relationships may be an artifact of a longer sampling period. These findings corroborate previous findings that suggest that D2 (across time) moves farther away from D1 when positioned ≤ 1 m from D1 at the start of the event, and that D2 moves closer to D2 when positioned farther away than 1m at the start of the event (see section 5.2).

A similar series of logistic regression tests were performed to answer the question: can the length of D1’s click train predict whether or not D2 moves to or remains within a 10° or 30° angle of D1. Tests were conducted for D2 remaining within either a 10° or 30° angle, or moving to a 10° or 30° angle for both the start of the event and at 0.5 sec. Results are found in Table 5.9.

Table 5.9 Logistic regression showing different head angle conditions with length of D1’s click train as the predictor

	B	S.E.	Wald	df	Sig.	Exp(B)
Remain under 10° from start	1.858	1.555	1.429	1	.232	6.414
Remain under 10° from .5 sec	.746	.747	.998	1	.318	2.109
Remain under 30° from start	.570	.323	3.106	1	.078	1.768
Remain under 30° from .5 sec	.735	.328	5.033	1	.025	2.085
Move within 10° from start	.344	.115	8.961	1	.003	1.411
Move within 10° from .5 sec	.377	.120	9.838	1	.002	1.458
Move within 30° from start	.328	.138	5.675	1	.017	1.389
Move within 30° from .5 sec	.452	.137	10.851	1	.001	1.571

Where significant relationships were found for the logistic regression, similarly significant differences in the means were also found for an independent sample t-test for those sample conditions. For the t-tests, the mean length of the click train was compared between yes and no responses. The results of the t-tests for those conditions where significant relationships were found in the logistic regressions is as follows: remain under 30° from 0.5 sec: (t(36)=-2.609; p<0.013) (Yes, mean length = 1.22 sec; No, mean length = 2.38 sec). Move within 10° from start: (t(142)= -3.271; p<0.001) (Yes, mean length = 2.91 sec; No, mean length = 1.88 sec). Move within 10° from 0.5 sec: (t(141)=-3.482; p<0.001) (Yes, mean length = 3.05 sec; No, mean length = 1.92 sec). Move within 30° from start: (t(98)= -2.540; p<0.013) (Yes, mean length = 2.47 sec; No, mean length = 1.63sec). Move within 30° from 0.5 sec: (t(108)= -3.743; p<0.01) (Yes, mean length = 2.90 sec; No, mean length = 1.72sec). As in the results for distance, these head angle tests suggest that the longer the click train length, the more likely D2 is

to move to within a 10° or 30° angle of D1 during the episode, and the more likely D2 will move out of a 30° angle if already within that angle. Again, this relationship may be an artifact of a longer sampling period of longer click trains, and corresponds to the trends for changes in head angle across time observed earlier in section 5.3.

5.5.4 *Causality, silence and the OZE*

In order to help determine if D1's echolocation activity on the camera is in fact the cause of D2's behavior for those tests where significant relationships were found, it was necessary to compare episodes where two dolphins in the OZE to the general baseline behavior of two dolphins swimming in front of the camera. Unfortunately, it is not possible to determine if changes in D2's head angle or distance are related to the behavior of D1 using this method because head angle information for the baseline data set (Data Set 1) is not available. However, it is possible to compare the echolocation behavior of D2 when in the OZE to the 'normal' echolocation behavior of dolphins. As was outlined in section 4.2 for Data Set 1, the number of instances where either 1 or 2 dolphins echolocate for each of the 1 second intervals for all 130 episodes was calculated (excluding those where 0 dolphins echolocated). The number of cases where 1 dolphin is observed echolocating on the camera is N=47. The number of cases where 2 dolphins are observed echolocating on the camera is N=65. Therefore, for normal circumstances where D1 is echolocating on the camera while 2 dolphins are swimming together (≤ 1 m apart and less than approximately a 90° head angle), D2 will be echolocating 58% of the time. We can now compare this observed baseline behavior to D2's behavior for those cases in which *D2 remained in the OZE throughout the eavesdropping episode*. If these behaviors are significantly different, we may be able to conclude that being in the OZE causes dolphins to behave in ways different to normal dolphins.

For the first test, the OZE was defined as two dolphins ≤ 1 m apart, with heads positioned within 10°. Unfortunately, the number of instances where a dolphin actually remained inside the OZE throughout the duration of D1's echolocation bout given these criteria is too small (N=1), rendering this test impossible.

For the second test, the OZE was defined as two dolphins ≤ 1 m apart, with heads positioned within 30°. The instances of dolphins in the OZE throughout the duration of D1's echolocation bout (i.e., from 0.5 seconds onward) where D2 echolocates (N=2) vs. D2 remaining silent (N=4), were compared to the baseline echolocation activity of 2 dolphins; 1 dolphin echolocates (N=47) vs. 2 dolphins echolocate (N=65). The difference in proportions was not significant for Fisher's exact test (2-tailed)($p < 0.40$).

For the third test, the OZE was defined as two dolphins ≤ 1.5 m apart, and with heads within 10°. The instances of dolphins in the OZE throughout the duration of D1's echolocation bout (i.e., from 0.5 seconds onward) where D2 echolocates (N= 3) vs. D2 remaining silent (N=0), were compared to the baseline echolocation activity of 2 dolphins; 1 dolphin echolocates (N=47) vs. 2 dolphins echolocate

(N=65). The difference in proportions was not significant for Fisher's exact test (2-tailed) ($p < 0.27$).

For the fourth test, the OZE was defined as two dolphins ≤ 1.5 m apart, and with heads within 30° . The instances of dolphins in the OZE throughout the duration of D1's echolocation bout (i.e., from 0.5 seconds onward) where D2 echolocates (N=5) vs. D2 remaining silent (N=6), were compared to the baseline echolocation activity of 2 dolphins; 1 dolphin echolocates (N=47) vs. 2 dolphins echolocate (N=65). The difference in proportions was not significant for Fisher's exact test (2-tailed) ($p < 0.53$).

Of interests here is the fact that the number of cases where D2 remains in the OZE throughout the duration of D1's echolocation are in fact quite limited. Even with the most liberal definition of the OZE (i.e. ≤ 1.5 m apart and head angles at $\leq 30^\circ$), the total number of cases where D2 remains in the OZE is N=11; just 6% of all episodes. For all of the above tests, there was no difference between D2's behavior when in the OZE compared to the normal echolocation behavior of 2 dolphins inspecting the camera. It is then impossible to conclude that D2's echolocation behavior when in the OZE is in any way caused or influenced by the behavior of D1, since D2's behavior is indistinguishable from 'normal' dolphin behavior. These findings help explain the relationship between head angle, distance and silence that was discussed in section 4.3.3. For those earlier tests, larger distances and head angles appeared to be predictors of D2 remaining silent, but only for those cases well outside the OZE. This recent series of tests corroborate these findings in that distance and head angle do not predict silence for dolphins in the OZE, therefore the predictive power of distance and head angle must lie outside the OZE (as was found in the earlier tests). The only predictor of silence appears to be both the presence and length of D1's echolocation train for the eavesdropping data set. The significant differences between the baseline and the eavesdropping data sets observed in section 4.2 do not then appear to be related to D2's position either inside or outside the OZE (as it is defined here), but instead appear exclusively related to the presence of echolocation activity by D1.

Chapter 6 General Discussion

6.1 Summary of main findings

Three operational hypotheses were conceived for this study, as a means of directly testing the echoic-eavesdropping hypothesis on a population of wild bottlenose dolphins. These hypotheses are:

H1- An echoic eavesdropping dolphin remains silent for the duration of the investigating dolphin's echolocation click train during investigative events

H2 – A dolphin positioned in an appropriate eavesdropping position when another dolphin initiates echolocation remains in that swim position throughout the duration of the investigating dolphin's echolocation click train during investigative events

H3 – A dolphin not positioned in an appropriate eavesdropping position when another dolphin initiates echolocation will attempt to initiate an appropriate swim position after the begin of the investigating dolphin's echolocation click train during investigative events

A series of statistical analyses were conducted in order test these hypotheses, ultimately yielding results that were sufficiently clear and consistent to allow us to reject the null hypothesis for H1, but not reject the null hypotheses for H2 and H3. Concerning H1, it was found that:

- When compared to the baseline behaviors of dolphin dyads, D2 (a potentially eavesdropping dolphin) was more silent in the eavesdropping data set.
- When large distances and head angle are controlled for in the eavesdropping data set (so that they are equal to the distances and head angle for the baseline data set), D2 is still more silent than in the baseline data set

These results suggest that D2 (as measured in the eavesdropping data set) will remain more silent than a 'normal' dolphin, and that this silence is a result of the D1's commencement of an echolocation click train on the camera. A variety of potentially confounding factors were examined, and it was not found that any outside influences (from either sampling protocol problems or 'mechanical' behavioral influences) have biased these results. Thus, we can reject the null hypothesis, and find positive evidence that 'An echoic eavesdropping dolphin remains silent for the duration of the investigating dolphin's echolocation click train during investigative events.' In this sense, an 'echoic eavesdropping dolphin' is understood to be a dolphin that is relatively near (i.e., the two dolphins are within <2 m and with <90° head angle) D1 at the start of D1's investigation of the target with echolocation.

It was found, however, that distance was not a reliable predictor of whether or not D2 would remain silent when in an 'echoic eavesdropping position', despite the fact that 'an echoic eavesdropping

dolphin' is defined as one located at <2 m and with <90° head angle (as described in the above control). When the distance variable was tested using a variety of statistical techniques, it did not provide any evidence that it could predict silence for an echoic eavesdropping dolphin. Similar results were obtained for tests where the optimal zone for eavesdropping (i.e., the OZE) was defined, involving both distance and head angle. When the echolocation behavior of dolphins in the OZE for the eavesdropping data set was compared to that of baseline dolphins, no difference was found (despite even liberal definitions of the OZE).

Interestingly, head angle was found to be a predictor of silence in an echoic eavesdropping scenario when tested at some time intervals (e.g. 0.5 sec) according to logistic regression analysis. The results of independent t-tests revealed that silence occurred most often when dolphins' heads were positioned at larger angles; that is, the closer dolphins' heads are in terms of head angle, the more likely D2 will echolocate on the camera. A possible explanation for this finding is that dolphins found in swim positions with head angles >45° (an angle similar to the mean head angle where silence was seen in the t-tests for most time intervals) are less likely to be facing the camera, and therefore less likely to initiate investigation on the camera on the whole. However, given the apparent trend for head angles to decrease during an eavesdropping episode (as described in section 5.3), this explanation does not seem appropriate. Furthermore, a 45° head angle should still allow an eavesdropper to have attention focused on both the video camera and/or D1's returning echolocation clicks. Despite this finding, the fact is that dolphins in an echoic eavesdropping scenario remain more silent than in the baseline scenario. An alternative explanation as to why it appears that closer head angles lead to more echolocation activity for an eavesdropping dolphin is offered in section 6.2.2.2.

Concerning both H2 and H3, it was found that:

- When examining distance on its own, it appears that dolphins starting in the OZE appear to move further apart whereas dolphins starting outside the OZE move closer together.
- Distance between dolphins as measured at time intervals near the start of the event are not a predictor of whether or not D2 will remain or move closer to D1.
- When measuring head angle on its own, there is a weakly significant tendency for head angle to decrease throughout the eavesdropping episode (when measured from 0.5 sec onwards).
- For head angle, the angle measurement at the start of the event is a predictor of whether or not D2 moves to within 10° or 30° of D1 at some point during the episode; that is, the closer the dolphins' heads at the start, the more likely D2 moves within 10° or 30°.
- For head angle, if the OZE is defined as 30°, head angle measured at 0.5 sec is a predictor of whether or not D2 maintains head alignment; the closer the dolphins' heads, the more likely D2 remains within 30°.

- Despite the previous observation, D2 is, overall, no more likely to maintain a head angle $<30^\circ$ than he/she is likely to maintain a $>30^\circ$ head angle during an eavesdropping episode.
- When the OZE is defined in terms of both head angle AND distance, D2's behavior in terms of remaining in/outside or moving to/from the OZE is no different depending on a starting position either inside or outside the OZE. As a result, D2 is just as likely to remain in the OZE as remain outside the OZE during an eavesdropping event.

These results suggest that D2 neither maintains a position within the OZE, nor attempts to move into the OZE during an eavesdropping episode. As a result, there is no reason to reject the null hypothesis for either H2 or H3. However, two important trends were observed. Firstly, it appears that dolphins positioned 1 m or less from each other at the start of the eavesdropping event will move farther apart during the course of the episode, whereas dolphins positioned greater than 1 m apart will move closer together. Secondly, there is a tendency for D2 to decrease head angle during an eavesdropping event. Combined with the observation that head angle at 0.5 sec is a predictor of whether or not D2 will maintain head alignment within 30° , and that head angle at the start of the event predicts whether or not D2 moves to within 10° or 30° of D1, this might be interpreted to mean that there is some limited evidence that dolphins display some level of eavesdropping behavior in terms of head angle changes during eavesdropping events. The distance results suggest that dolphins may in fact be moving toward an unknown 'ideal' spacing distance that is between the current definitions of the OZE, perhaps lending support to H3.

However, in conjunction with these positive results, it was also found that head angle measured at 30° is also a predictor of whether or not D2 would echolocate, and that the prediction was that the closer two dolphins heads are together (in terms of angle) the *more likely* D2 would echolocate. This is corroborated by the strong correlation seen between the variables 'did D2 shift' and 'did D2 echolocate', suggesting that when a dolphin does turn to 'face the camera', he/she will also echolocate. When taken together, this means that dolphins with closer head angles are more likely to both echolocate and maintain head/initiate alignment. In summary, I find some evidence to support H2 when defining the OZE only in terms of head angle, but the overall tendency for D2 to decrease head angle with D1 was weak, and despite head angle's predictive powers (when measured at very specific parameters), there was, overall, no tendency for D2 to remain in the OZE. Furthermore, the fact that closer head angles predicts more echolocation and less silence is not support for the overall hypothesis in terms of what is expected of an eavesdropping dolphin. A possible explanation of these findings is as follows: it may be the case that a closer head angle means nothing more than a tendency for D2 to also 'notice' the camera, and therefore move/maintain head alignment with D1 simply because both dolphins are investigating/echolocating on the camera at the same time, and, consequently facing the same direction. The trends for D2 to increase and/or decrease swim distance is certainly interesting, although this finding does not indicate that dolphins are remaining in/moving into the OZE. Thus,

despite those cases where some positive evidence was found, taken as a whole, there is no compelling evidence to support H2 or H3 as a result of this study.

Further evidence that suggests that we should reject both H2 and H3 in terms of a dolphin engaging in eavesdropping behavior when in the 'ideal eavesdropping position' is the observation that the actual percentage of episodes where D2 is inside the OZE at the start of the episode when compared to all episodes for Data Set 2 is just 4%. The percentage of dolphins remaining inside the OZE (when measuring from 'start of event') is 0%, and when measuring from '0.5 sec' is just 2%. Even with the most liberal definition of the OZE (i.e. ≤ 1.5 m apart and head angles at $\leq 30^\circ$), the total number of cases where D2 remains in the OZE is $N=11$; just 6% of all episodes. Overall, D2 does not appear to spend much time in the OZE during eavesdropping events, an unexpected finding according to our conceptual hypothesis that states: dolphins traveling in dyads engage in echoic eavesdropping behaviors when inspecting a target. If 'eavesdropping behaviors' is defined in terms of behavior in relation to the OZE, this is most certainly not correct.

There are a series of additional observations that are worth noting:

- Age, gender and clockface swimming position appear to have no influence on D2's behavior in terms of either echolocation/silence or swim position (i.e., head angle and distance).
- Calf echolocation behavior was not found to be significantly different to the echolocation behavior of juvenile, sub-adult and adult dolphins.
- D2 was observed most often in the 3:00, 6:00 and 9:00 swim position, which is perhaps indicative of a general swimming trend for dolphin dyads, although it appears to be unrelated to eavesdropping behavior.
- Head angle and distance measurements are strongly correlated; the larger the distance between two dolphins, the larger the head angle measurement.
- The mean length of D1's echolocation click train was much longer for those episodes where D2 eventually echolocated.

Also, an important discovery was made that requires further explanation: when measuring changes in head angle and distance using the 'start of event' time interval as the actual start of the episode, strange trends were noticed, namely that head angle and distance appeared to increase between the start of the event and 0.5 sec. After 0.5 sec however, this trend either disappeared or reversed itself (i.e., head angle and distance decreased). It could have been assumed that the 'start of event', that is, the onset of D1's echolocation, was causing this brief increase in head angle and distance between the two dolphins. However, upon more detailed examination of the data, an explanation was found for this strange 'jump' in measurements. When describing the binary variable 'D1 facing camera at start of event yes/no', it appears that D1 is facing in the direction of the camera only 65.6% of the time, meaning that D1 engages echolocation on the camera when facing away from the camera in more than

one third of recorded episodes (34.4% of the time). When describing the binary variable 'D1 facing the camera 0.5 sec yes/no', D1 is facing the camera 91.6% of the time. This reveals that D1 will turn to look at the camera during the first 0.5 sec after engaging echolocation for those episodes where he/she is not already facing the camera. Thus, for a hypothetical example episode where dolphin head angle is measured at 20° at the start of the event, in 34.4% of cases, we may expect to see that this head angle will increase to 50° as D1 turns to face the camera after engaging echolocation while not looking at the camera. On average, the trend then suggests that D2 will also turn to face the camera, which is why, when measured after the 0.5 sec interval, head angle between dolphins appears to decrease across time. This 'jump' in measurements produces anomalies in many of the tests designed to test for trends in measurements across time, and the predictive powers of various variables. After this discovery, the 0.5 sec time intervals was used as the start of event variable for many tests, providing a more accurate portrayal of D2's movements in relation to D1 when D1 is inspecting the camera.

Also, it was found that the length of D1's echolocation click train was a reliable predictor of whether or not 1) D2 would move to within 10°, 30°, and 1 m of D1 when positioned outside those measurements, and 2) D2 would move farther away than 10°, 30°, and 1 m of D1 when positioned inside those measurements. These findings corroborate previous findings that suggest that D2 (across time) moves farther away from D1 when positioned ≤ 1 m from D1 at the start of the event, and that D2 moves closer to D2 when positioned farther away than 1m at the start of the event, as well as the findings that head angle tends to decrease across time overall. It is not entirely clear why a longer click train would cause D2 to both move closer to D1 when positioned far away, but farther away from D1 when positioned closer together, other than the possibility that the trend for dolphins to make these movements is more pronounced across time in general. That is, the longer the episode, the more movement is observed, so this relationship actually describes sampling length and not click train length per se. However, this does not explain why a longer click train appears to predict an increase in head angle for dolphins that are swimming closer together. Given that the overall trend is for D2 to decrease head angle, this does not seem to fit well with the given explanation. It may well be that the predictive powers of 'D1's click train length' as a variable are somehow made less reliable given the influence of the 'jump' bias described above. That is, there is a trend for head angle and distance to increase in the first 0.5 sec after D1 begins echolocating (due to the fact that D1 is facing away from the camera in 34.4% of episodes), and that this trend is not accurately reflected in the 'length of D1's click train' measurement. This problem may then confound the results describing predictive powers for this variable in terms of changes in head angle and distance. As a general observation however, these results are difficult to explain.

A list of the most important positive findings following from this study is included below:

- A dolphin is more silent than normal at times when another dolphin initiates echolocation on the camera.

- Dolphins move farther apart when positioned less than 1 m at the start of an event, and closer together when positioned greater than 1 m during an eavesdropping event.
- Head angle between two dolphins decreases not long after one of the dolphins initiates echolocation on the camera.
- A second dolphin is more likely to turn to face and then echolocate on the camera if head angle is closer together with the first dolphin just after the first dolphin begins echolocating.

The importance of these findings and their impact on the echoic eavesdropping hypothesis and joint attention in dolphins will be explored in the following section (6.2)

6.2 Implication and interpretation of results

6.2.1 Overview

As described in section 1.3, the aims of this thesis are twofold: 1) to determine if wild Indo-Pacific bottlenose dolphins (*Tursiops aduncus*) engage in behaviors predicted to follow directly from the ‘echoic eavesdropping’ hypothesis in a natural setting, and 2) to explore how these natural behaviors are related to a discussion of joint attention in dolphins. The guiding conceptual hypothesis, applicable to a test of observational data on wild dolphins is: dolphins traveling in dyads engage in echoic eavesdropping behaviors when inspecting a target. The work of Xitco and Roitblat (1996) provided the foundation upon which the conceptual hypothesis was based, and examination of their research results suggested an echoic eavesdropping ability for two captive bottlenose dolphins participating in an object discrimination task yielded two important predictions: 1) dolphins will remain silent while engaged in echoic eavesdropping, and 2) dolphins need to be in an ‘ideal’ position in order for echoic eavesdropping to occur. These predictions led directly to the three operational hypotheses described in this study.

The results of the statistical tests for this study suggest positive evidence for H1, but no reason to reject the null hypothesis for H2 or H3. It would appear that the idea that an ‘ideal eavesdropping position’ (the OZE) exists and that an eavesdropping dolphin in this position is more likely to eavesdrop (i.e., continue to remain silent and continue to remain in the ‘ideal’ position) is not supported by the data. Nor was any evidence found to suggest that dolphins appear to move into an eavesdropping position in order to engage in the behaviors predicted by the hypothesis. Thus, for the two predictions stemming directly from the Xitco and Roitblat (1996) experiment, evidence was found for silence, but not for an ideal eavesdropping position. These results and their implications for the various conceptual underpinnings of the echoic eavesdropping hypotheses will be discussed in detail in section 6.2.2.

Positive evidence was found suggesting that (putative) eavesdropping dolphins will remain more silent than normal, and decrease head angle after another dolphin begins to echolocate on the camera.

These behaviors, particularly the marked decrease in head angle during an eavesdropping episode, are important to a discussion of joint attention (and in particular bimodal joint attention) in dolphins, as well as echoic eavesdropping in general.

6.2.2 Echoic eavesdropping

In review section 2.1, a variety of conceptual issues surrounding the echoic eavesdropping hypothesis were discussed. These concepts, as well as related claims and hypotheses, will be re-visited here in light of the results from this study.

6.2.2.1 Silence

One of the major findings of this study was support for the hypothesis that dolphins in an eavesdropping scenario remain silent. There are, however, some very important qualifications of these findings that must be pointed out. When compared to the ‘baseline’ behavior of dolphin dyads in front of the camera, it was found that dolphins in an eavesdropping scenario remained more silent than baseline dolphins. The definition of the ‘eavesdropping scenario’ in these tests was ‘the length of D1’s initial click train directed at the camera’. Thus, we can state that D2 is more likely to be silent than ‘normal’ during D1’s initial echolocation on the camera. This is true even after we remove possible bias caused by D2 being far away from D1 for the eavesdropping episodes in Data Set 2. However, it should be noted that for the eavesdropping data set (i.e., Data Set 2), D2 was silent only 29.2% of the time (N=50). Thus, even though there was more silence than normal, D2 remains silent in less than one third of the eavesdropping scenarios, which is not a robust finding insofar as silence might have been expected much more often from an eavesdropper. It is also important to point out that the closer the head angles between dolphins, the more likely D2 will echolocate. Furthermore, there is a strong correlation between those episodes where D2 ‘shifted to face the camera’ and D2 initiated echolocation. As a general rule, it appears that an eavesdropper is more silent in those scenarios where he/she is not in close alignment with D1, but still close enough to receive click echoes. This is corroborated by the findings that the OZE itself (i.e., the optimal zone for eavesdropping) appears to play no role in predicting whether or not D2 will remain silent.

Perhaps, however, this extra silence for the eavesdropping scenario can be explained in another way. When the echolocation data from Data Set 2 were re-sampled using the more appropriate sampling technique (see section 4.2), it appears that this extra silence observed for eavesdropping dolphins might in fact be most prevalent for those brief moments just before D2 eventually echolocates. In this sense, an eavesdropping scenario may not elicit a response from D2 where D2 does in fact remain silent *throughout* the duration of D1’s echolocation click train (as is hypothesized), rather it may elicit a response where D2 is silent for a *little bit longer* than normal before then engaging echolocation. Perhaps the behavioral norm is then for D2 to hear the onset of D1’s echolocation, and then ‘close the gap’ in terms of head angle while listening to D1’s echolocation before then engaging echolocation on the camera. If this is the case, this would explain why 1) closer head angles seem to be correlated with the onset of D2’s echolocation, and 2) head angle between eavesdropping dolphins appears to

decrease across time. D2 may be benefiting from D1's echolocation information while she moves herself into a position (in terms of head angle) that will allow her own echolocation to be most effective when inspecting the camera. While it appears to be true that silence is more prevalent in eavesdropping scenarios, it is not correct to conclude that eavesdropping dolphins always remain silent during an eavesdropping episode. With this in mind, the role that silence plays for the echoic eavesdropping hypothesis can now be explored more fully.

The echoic eavesdropping hypothesis (as described in section 2.1.9, and in H1) predicts that an eavesdropping dolphin will remain silent in order to maximize the information gained from the reception of click echoes originating from the biosonar of conspecifics. Some authors have cited silence as the defining characteristic of eavesdropping for studies on wild dolphins (dos Santos & Almada, 2004; Götz *et al.*, 2005). Many possible reasons why silence is assumed to be associated with echoic eavesdropping, have been offered, including reduced metabolic, predation or detection costs, as well as to prevent jamming. This study has provided some valuable insight into the jamming issue. The jamming argument states that dolphins will reduce echolocation so as to avoid jamming the effectiveness of each other's biosonar. The findings from this study do not provide support for the idea that a JAR (jamming avoidance response) is the primary cause of silence. While more silence was indeed found for echoic eavesdropping dolphins, it is important to note that, even in those instances where D1's click train length was correlated with D2's silence, D2 did in fact ultimately engage echolocation. Furthermore, the evidence from this study suggests that D2 was less silent as the dolphin's heads were more closely aligned; a fact that is not in keeping with a JAR which would predict the exact opposite. Jamming avoidance must not then be considered the reason for which dolphins in this study remain silent. A better explanation is likely related to either a reduced cost (perhaps metabolic cost), or perhaps a social role (as will be outlined in section 6.2.2.4).

In general, this study supports the notion that dolphins are indeed more silent during echoic eavesdropping scenarios. However, silence for this study is not as robust as is predicted by the hypothesis, and does not appear to result in total silence as might be predicted. In those instances where silence for this study seems to occur (only 29.2% of the time), silence occurs most often when dolphins' heads are at larger angles. Smaller angles (and thus 'better' eavesdropping positions) appear correlated with echolocation production and not silence. Why is this the case? There are two possible explanations. It might simply be the case that when D2 is positioned in such a way that his head is close together with D1 (who is actively investigating the camera), D2 will then, by virtue of the fact that he is now also facing the camera, be inspired to investigate the camera. That is, D2 simply notices the camera and begins an echolocation bout a few seconds after D1. The fact that closer head angles predict D2's echolocation behavior means simply that a closer head angle increases the likelihood that D2 notices the camera. However, there are some problems with this explanation. This does not explain the finding that more silence is seen in the eavesdropping scenario than the baseline scenario. If D2 were simply 'noticing the camera a few seconds after D2', then one would not expect these findings, as there is equal opportunity for D2 to 'notice' the camera in the baseline scenario. There is

another explanation for this apparent increase in echolocation behavior from D2 as head angles increase, and it requires the introduction of a novel hypothesis; the multi-source echoic eavesdropping hypothesis.

6.2.2.2 *Multi-source echoic eavesdropping*

For this study, it was found that the closer dolphin's heads are to each other, the more likely they are to simultaneously engage echolocation. This is not in keeping with the current echoic eavesdropping hypothesis as it relates to jamming. Therefore, given the considerable ambiguity present in many of the fundamental concepts underpinning echoic eavesdropping (as has been outlined in section 2.1), there is opportunity for the introduction of a competing hypothesis. Although Götz *et al.* (2005) observed a potential echoic eavesdropping scenario where silence appeared to play an important role, with potentially similar data presented by Lammers *et al.* (2006), it has not been convincingly argued that an eavesdropping dolphin must remain silent in order to receive valuable echo information, nor has this been shown to be the case for this study. Like Jerison's (1986) suggestion that multiple individual dolphins echolocating in unison may enhance perception, it may be possible that a dolphin is able to resolve adequate or possibly even enhanced object information by combining backscatter originating from a multi-source system, even while itself actively echolocating. Similar to the scenario envisioned by Kuc (2002), if a dolphin's echo processing system 'knows' the distance to the sources and if this distance remains near constant, and if the system can match echoes to sources, enhanced target information might be possible. It is important to note that when faced with an experimental target identification task of increased complexity, dolphins are known to emit more echolocation clicks than for easier tasks (Helweg *et al.*, 1996b). As this seems to be the only feature the dolphin manipulates for difficult tasks, it could be assumed that more information resulting in better resolution is achieved through emission of an increasing number of clicks. Detection ability has been shown to increase as the number of click echoes available to the dolphin increases (Altes *et al.*, 2003). Dolphins appear to recognize objects by integrating information found across multiple echoes in an echo train (Helweg *et al.*, 1996a). Therefore, multiple sources ensonifying a target simultaneously could result in a faster and more efficient means of increasing target identification if a dolphin can process multiple echo structures. Swimming in predictable and stable formations while concurrently emitting multi-source echolocation clicks could be a strategy for rapidly increasing target resolution; this would certainly be a substantial benefit. This could also result in earlier detection of remote prey, obstacles and predators, increasing foraging efficiency, and threat identification.

This reasoning forms an alternative to the echoic eavesdropping hypothesis as has been presented: 'multi-source echoic eavesdropping'. Like echoic eavesdropping, this alternative hypothesis suggests that dolphins are able to glean useful object information from listening to the returning echoes generated by the echolocation activity of conspecifics. However, it predicts that a dolphin will receive enhanced object information more rapidly by listening to the echolocation activity of conspecifics in combination with its own echolocation. This suggests that dolphins will swim in appropriate swimming formation as a means of directing the group's echolocation on a specific target, increasing

target feature recognition and reducing target ambiguity, although other explanations for swimming formations are also possible (e.g., safety, forcing schooling behavior of prey species). Importantly, the echoic eavesdropping hypothesis and the multi-source echoic eavesdropping hypothesis may not necessarily be mutually exclusive. Dolphins may in fact be capable of single or multi-source eavesdropping, and could switch between either depending on the appropriateness of the behavior to the given situation.

This in fact appears to be the case for the results of this study. In those episodes where D2 was silent before initiating echolocation on the camera, it could be argued that he/she was initially engaged in echoic eavesdropping before then engaging in multi-source echoic eavesdropping. Both behaviors might have produced some sort of benefit (for the former, a reduced metabolic cost, and for the latter, enhanced object information). It might well be the case that multi-source echoic eavesdropping is only effective when dolphins heads are appropriately aligned, which may be the reason why they appear to 'wait' with echolocation until their heads are aligned more closely. It may also explain why D2 is more likely to engage echolocation as D1's click train length increases; that is, D2 may only engage echolocation 1) when in a position allowing for multi-source echoic eavesdropping, and 2) only if D1 is still echolocating once D2 reaches that position. If D2's echolocation click train ends before D2 has a chance to 'get in position', D2 will not echolocate. Alternatively, this same finding suggests that it may be the case that D1 will increase the length of its click train when exposed to the echolocation activity of D2. In this scenario, the longer click train observed for D1 in those scenarios where D2 echolocates may be a sign that an ideal multi-source position has been achieved. However, the opposite might also in fact be true: perhaps D1 increases click train length because D2 is somehow jamming D1 with its clicks. Whether or not multi-source echoic eavesdropping is the reason why dolphins appear to behave in the ways described for this study remains to be seen, but in either case, jamming avoidance does not appear to be the reason for silence as seen in this study.

6.2.2.3 Listening position and off axis problems

As was discussed in sections 2.1.5 and 2.1.6, there is currently no consensus as to what listening positions allow an echoic eavesdropping dolphin to receive enough information allowing for object discrimination and detection. Xitco and Roitblat's (1996) experiment suggested that the 'ideal' position would require the dolphins to be positioned very close together, with head angles more or less perfectly aligned. Support for this notion is found in the many experiments describing the structure of the dolphin's echolocation beam. However, other studies have suggested that dolphins may receive adequate echo information over larger distances. Nonetheless, this study was based on the idea that there exists an ideal listening position (i.e., the OZE), and that the behaviors assumed to be concomitant with echoic eavesdropping (remaining silent and maintaining close head angle and swim distance) would more likely occur when in the OZE. Support for this idea was not in fact found. Based on the results, we could not reject the null hypothesis for either H2 or H3.

The rarity with which dolphins appear to spend any time in the OZE challenges the notion that

dolphins in the wild regularly enter into close proximity swimming positions for the purpose of echoic eavesdropping. This is in direct contrast to the results of Götz *et al.* (2005) that found that synchrony was directly correlated with silence. Synchrony for their study included dolphins involved in close, mirrored swimming behaviors. The evidence from this study suggests that dolphins eavesdropping on the echolocation activity of conspecifics do so without engaging in synchronous swimming behavior. This finding may have more in common with the findings of Akamatsu *et al.* (2005), wherein it was calculated that a porpoise was able to use the off-axis portion of its echolocation beam to receive object information.

Despite these conclusions, another interpretation of the results is possible. Silence (and thus the expected ‘eavesdropping’ behavior) is clearly not associated with the OZE, close swimming proximity, or head angle and swim distance in general. However, the trend whereby dolphins appear to move their heads closer together during an eavesdropping episode (independent of silence), and where D2 remains silent before eventually engaging echolocation (when eventually facing the camera/aligned with D1), offers a novel interpretation of the function that an ‘ideal listening position’ might have. If, as has been proposed in section 6.2.2.2, dolphins engage in multi-source echoic eavesdropping, then it may be the case that they withhold echolocation activity until aligned with an echolocating dolphin, at which point the two dolphins echolocate in unison. In this scenario, it would appear that close head angle is an important requirement for multi-source echoic eavesdropping if the observed silence is in fact indicative of a dolphin ‘getting into a better eavesdropping position’. Perhaps closely aligned heads are vital for a multi-source echoic eavesdropping scenario to emerge, which is why D2 appears to remain silent until this position is achieved. It is also possible that this silent period (despite the fact that it is correlated with the length of D1’ click train) may simply be an artifact of the time it takes D2 to face the camera before engaging echolocation, and that this behavior is performed without regard to D1’s head angle. This finding requires more investigation. Further experimental investigation of ideal listening positions for either echoic eavesdropping or multi-source echoic eavesdropping will shed light on this issue.

6.2.2.4 The social problem, the features problems and the outgoing click

It is possible that the silence that was observed for this study (either in terms of complete silence during an episode, or the silence before D2 engages echolocation), is related to the social status of the dolphins in questions. It should be noted however, that no difference in echolocation behavior, or which dolphin was in the role of either D1 or D2, could be associated with age or gender. Given this, there is no evidence from this study that these variables play a role in echoic eavesdropping.

6.2.2.5 Support for the proposed effects of echoic eavesdropping

The various claims as to the possible influence that a capacity for echoic eavesdropping may have on the behavior of wild dolphins are listed below, together with the impact that the results of this study have on these claims:

Claim: Synchronous behavior may be a strategy employed by dolphins in order to maximize received echo information generated by conspecifics (Götz *et al.*, 2005; Kuc, 2002; Xitco & Roitblat, 1996).

Support from this study: As outlined above, synchronous swimming does not appear to be a behavior associated with echoic eavesdropping as was found for this study. Some level of synchrony may be involved if multi-source echoic eavesdropping is occurring however. Overall, this study finds no evidence to corroborate the assertion that synchronous dolphins engage in echoic eavesdropping (at least for this study design).

Claim: Echoic eavesdropping may influence swimming formations used during foraging (Janik, 2005).

Support from this study: It may well be the case that echoic eavesdropping does influence the swimming formation(s) of dolphin groups. As suggested by this study, these distances may be much larger than is currently supported by the echoic eavesdropping hypothesis. Echoic eavesdropping may occur over large distances depending on the saliency of the echo information that is required for foraging tasks.

Claim: Norris and Dohl (1980) discussed how echolocation by a group of dolphins may result in ‘shared information’ and ‘sensory integration’, concepts similar to, and perhaps facilitated by, echoic eavesdropping. This ‘sensory integration’, including the rapid transmission of acoustic sensory information between members of a group, has also been discussed by Fellner *et al.* (2006). Herzing (2006) discussed the need to understand echoic eavesdropping and its relationship to swimming positions as it relates to the analysis of shared cognitive information.

Support from this study: These suggestions may have found some support in the results of this study. Silence was found to occur for dolphins in an echoic eavesdropping scenario. And if multi-source echoic eavesdropping is the explanation for dolphins with closely aligned heads echolocating on the camera in unison, then ‘sensory integration’ (in terms of combined echo information) may be occurring. This may in fact be found for groups of dolphins as well as dyads.

Claim: The relationship between echoic eavesdropping, shared information, group synchrony, and a dolphin’s proposed ability to utilize complicated cognitive processes are possible support for Theory of Mind in dolphins, as discussed by Harley *et al.* (1995).

Support from this study: As will be argued in section 6.2.3.8, the results of this study have no relevance to a discussion of Theory of Mind, although they most certainly are important to a discussion of joint attention (see section 6.2.3). It has been previously argued that Theory of Mind does not flow easily from a discussion of joint attention in dolphins (or other animals) (see section 2.2.3.4).

Claim: Group echolocation strategies (including echoic eavesdropping) may lead to social behavior that dictates which dolphin echolocates and when, possibly resulting in echolocation ‘emission rules’ like those discussed by dos Santos and Almada (2004). Echoic eavesdropping behavior may influence

the social hierarchies and the rotating social roles that facilitate shared echolocation duties suggested by Johnson and Norris (Johnson & Norris 1986; Johnson & Norris, 1994).

Support from this study: As was discussed in section 6.2.2.4, it is possible that social roles are responsible for the silence observed in this study for eavesdropping dolphins. However, no evidence was found that gender or age was a predictor of silence or other eavesdropping behaviors.

Claim: The echelon swimming position commonly seen for mother-calf pairs may facilitate echoic eavesdropping, and possibly provide immature dolphins an opportunity to develop echolocation skills (Herzing, 2004).

Support from this study: Unfortunately, the number of episodes from Data Set 1 and Data Set 2 involving neonates were quite limited (N=3), so the echolocation behavior of neonates could not be explored in detail. However, the lack of support for an OZE in this study certainly diminishes the claim that close, synchronous swim positions facilitates echoic eavesdropping for neonates or other dolphins.

Claim: Echoic eavesdropping is a major component of conceivable communication systems for odontocetes (Dawson, 1991; Jerison, 1986).

Support from this study: Although there is some support for the idea that echoic eavesdropping involving silence does occur, this study does not provide any direct evidence that the behaviors involved with echoic eavesdropping are related to communication between/among dolphins.

6.2.3 Joint attention

As discussed in section 2.2, dolphins have exhibited a variety of behaviors that are commensurate with the claim that they have a special sensitivity to the attentional states of conspecifics. These observations are:

Dolphins comprehend (without training and on initial trials) the referential nature of the human pointing gesture

Dolphins comprehend (without training and on initial trials) the referential nature of the human gaze cue

Dolphins spontaneously produce pointing-like gestures

It has been proposed that echoic eavesdropping is a possible reason for this special sensitivity. In order to better understand the possible relationship between echoic eavesdropping and the above behaviors (which are directly related to a discussion of joint attention), a model of joint attention in dolphins was proposed (see section 2.3.2). Each of the cognitive mechanisms proposed by this model (the bimodal joint attention model) will now be re-evaluated in light of what was learned in this study. In addition, a variety of other cognitive abilities related to a discussion of joint attention will be re-

visited (e.g., eye detection, Theory of Mind) to see if these results of this study can further contribute to a discussion of joint attention in dolphins.

6.2.3.1 Eye detection mechanism

The bimodal joint attention model does not assume that dolphins possess specific sensitivity to the eyes of conspecifics. According to the model, the presence of an eye-detection mechanism is unlikely. As expected, there is no evidence from this study suggesting such a mechanism exists, nor is there any evidence to suggest it does not.

6.2.3.2 Reflexive attention shift and gaze/attention following

Reflexive attention shifts are considered to be automatic co-orienting in response to information available from the eyes or head orientation of another agent. It has been proposed (see section 2.2.2.1) that this mechanism develops early in life (for humans), and may be mediated by cells in the brain that are tuned specifically to eye information (see section 2.2.2.2). For bimodal joint attention, it has been argued that sensitivity to eye stimuli is unlikely to be involved (see previous section 6.2.3.1). However, some authors (e.g., Emery, 2000) have argued that reflexive attention shifts may actually be mediated by a combination of cues involving not only eyes, but also body and head cues. In the case of dolphins, where vision is often less important than echolocation, it might also be possible to include cues available in a different modality (i.e., echolocation) as triggering such a mechanism. If, for the case of bimodal joint attention, the ACS (alignment cue sensitivity) and ECS (echolocation cue sensitivity) that are proposed for dolphins do in fact exist and if these mechanisms are responsible for reflexive shifts in attention, then the results of this study may possibly provide support for the idea that reflexive attention shifts occur in dolphins.

It was found that an eavesdropping scenario, head angle between two dolphins decreases not long after one of the dolphins initiates echolocation on the camera. Given that this behavior coincides with silence behavior that appears to be mediated by the presence and length of D1's echolocation, it may well be the case that D2's behavior in this respect is something more than simply 'noticing the camera a few seconds after D1'. If this is the case, then the noticeable decrease in head angle may in fact be a result of a reflexive shift in attention that is caused by the ACS, the ECS, or both. Furthermore, in cases where D2 did eventually echolocate on the camera, the finding that 1) a second dolphin is more likely to turn to face and then echolocate on the camera if head angle is closer together with the first dolphin just after the first dolphin begins echolocating, 2) the longer a dolphin echolocates on the camera, the longer a second dolphin will remain silent before engaging echolocation, and 3) the longer a dolphin echolocates on the camera, the more likely a second dolphin will echolocate on the camera, suggest a secondary 'reflexive' behavior quite dissimilar to what is understood in non-echolocating animals. Given that a close head angle appears to result in more echolocation activity, a reflexive change in *echolocation attention* may in fact be occurring. Given that the emission of echolocation clicks is one of the primary methods available to a dolphin for obtaining object information, the production of echolocation only after first entering into close alignment with D1 may also be evidence

that the echolocation production itself is similarly mediated by a reflexive mechanism. Perhaps when D2 enters into this ‘ideal’ position (as predicted by the multi-source echoic eavesdropping hypothesis), the production of echolocation clicks is triggered ‘automatically’. If dolphins in an echoic eavesdropping scenario are behaving in ways related to reflexive shifts in attention, this may then occur in two ways: 1) a reflexive shift in head angle (co-orientation) upon hearing D2’s echolocation concomitant with perceiving D2’s body orientation, and 2) a reflexive production of echolocation clicks upon reaching an appropriate head alignment.

6.2.3.3 Alignment cue sensitivity (a bimodal joint attention model component)

For dolphins, an alignment cue sensitivity (ACS) has been proposed, consisting of a sensitivity to both body and head alignment (see section 2.3.2). This sensitivity has stimuli available to it across two modalities: vision and echolocation. For this model, the ACS ‘replaces’ the eye-detection sensitivity that is proposed for joint attention in primates. Given that the attentional information from dolphin eyes is ambiguous (given that the eyes are placed laterally, move independently, and are less detectable than primate eyes), the attentional information related to echolocation production has taken precedence. Echolocation is projected in a narrow beam emitted from the front of a dolphin’s head; therefore, the alignment of the head and the body is a reliable cue as to the direction of a dolphin’s (echolocation) attention. It is proposed that an observer dolphin could use the ACS, either alone or in combination with the ECS, to determine the focus of attention of another dolphin.

This study provides some evidence that dolphins do appear to change their behavior in relation to another dolphin’s alignment cues during an eavesdropping episode involving an object (the camera). Despite the fact the no evidence was found that dolphins appear to remain in or enter into a position in the OZE, it was found that dolphins do appear to increase head alignment during an eavesdropping episode. There are two possible explanations for this as far as attention is concerned 1) D2 initiates head alignment in order to learn more about the object, and subsequently uses only the information contained within D1’s receiving beam for orientation or 2) D2 initiates head alignment in order to learn more about the object, and subsequently uses the information found within D1’s body and head orientation to determine the ‘best’ receiving position for click echoes. The most likely explanation is a combination of the two; both ACS and ECS are available to a dolphin, and both provide information as to the location of the object in relation to D1’s attentional orientation.

It is perhaps unlikely that the ACS alone is enough to warrant a ‘reflexive’ attention shift in an observer dolphin. Such a mechanism would then be in a constant state of ‘shift’ as it encountered other dolphins in the environment. However, a reflexive shift may be triggered if echolocation is detected, causing the attentional state of an observer dolphin to search for salient directional cues that will lead it to the object in question. If ACS is not in fact a low-level mechanism (i.e., not an inbuilt pre-disposition to the significance of the body orientation of conspecifics as has been proposed for the eyes in primates), it may be that ACS is a learned sensitivity that is acquired through exposure to ECS cues that are inevitably concomitant with alignment cues. In either case, this study provides evidence

that dolphins are responding to some form of alignment cue, and the ACS is a likely candidate.

6.2.3.4 Intention detection (a bimodal joint attention model component)

The intentionality detector (ID), as has been described for the bimodal joint attention model (see section 2.3.2.3), is essentially the same as Baron-Cohen's (1995) ID mechanism as it pertains to his joint attention model. This mechanism attributes goal directed intentions to an agent based on the agent's observable behavior. In the case of bimodal joint attention, any of the behaviors involving an object (e.g., a fish) in combination with the observable attentional behaviors (i.e., echolocation activity or body/head orientation toward the object) allow an observer dolphin to infer that the agent has intentions toward the object (i.e., *intends* to catch, chase, approach). This ideal is akin to Butterworth and Jarett's model (1991), suggesting that the simple act of two agents reacting to each other's behavior so as to both focus attention on the object is evidence that each agent understands the 'intention' of the behaviors involved with regards the object. The results of this study suggest that D2 does appear to change behavior in reaction to D1's behavior (i.e., is more silent, reduces head angle), and, following from this model, we can suggest that the ID is also involved in these acts. However, without the results of controlled experiments (e.g., Call *et al.*, 2004), this remains only an assumption. Although one can conclude that D2's behavior has changed in reaction to D1's behavior, it can be argued (see Moore, 1998) that appealing to an ID mechanism is not necessary (see section 2.2.3.3). Unfortunately, the results of this study do not provide conclusive evidence of an ID mechanism in dolphins, at the same time however, one cannot discount the suggestion that the ID is a mechanism involved in bimodal joint attention.

6.2.3.5 Echolocation Cue Sensitivity (a bimodal joint attention model component)

Echolocation cue sensitivity (ECS) consists of two proposed mechanisms: transmitted echolocation beam perception (TEBP) and echoic eavesdropping perception (EEP). This study was in large part designed to investigate if dolphins appear to change behavior in response to a proven ability to eavesdrop on click echoes generated by conspecifics, and therefore to prove if they do have anything like EEP. As described in section 6.2.3.3, this study provided results indicating that dolphins appear to alter their behavior during an eavesdropping episode, revealing that they must be responding to some form of attentional cue.

Unlike most attentional sensitivities described for animal species, the EEP sensitivity is an 'object active' cue. This means that the involvement of an object as the target of another agent's attention state is not simply inferred by directional cues (e.g., ACS), but is in fact automatically and unavoidably apparent to an observer dolphins. As long as an observer is in a position where the echoes can be heard, some degree of object information will be contained within these echoes. The key problem with understanding EEP is determining if this echo information also automatically and unavoidably contains information about the location of the source of the echolocation that is generating the echoes. If this is the case, then the reception of click echoes means that an observer dolphin is also aware of the attentional state of the echolocating dolphin. Thus, EEP alone would

mean that a state of triadic attention is inevitable: D2 will know which object is the focus of D1's attention. Alternatively, EEP may simply predispose a dolphin to received object information through echoes, but not contain information as to the source of the echolocation generating these echoes. If this is the case, then the results of this study suggest that an observer dolphin is using additional cues to orient toward the object, and that these cues are either contained within the ACS, or possibly the TEBP. Either way, it appears that D2 does orient relative to the alignment cues of D1.

If there is a TEBP sensitivity, it would mean that a dolphin could avail of the information contained within the outgoing echolocation beam alone as an indication of where an object is located. It is not possible to determine from this study if dolphins do in fact alter behavior in response to TEBP; the study design assumes that EEP and TEBP are always acting in concert. It may be that outgoing clicks alone trigger a dolphin to engage in co-orientation behaviors (perhaps then availing of ECS and ACS), but given that both outgoing clicks and click echoes were always available to D2, this study can not provide evidence that this is the case. Nonetheless, the bimodal joint attention model suggests that these two mechanisms working in concert may lead to an observer dolphin's sensitivity to the attentional states of other dolphins in relation to an object.

6.2.3.6 Gaze monitoring

The bimodal joint attention model does not consider gaze monitoring to be an essential component of the model. It was suggested that, if dolphins do indeed monitor the head or body position of other dolphins, this could be done visually (using laterally placed eyes) while continuing to focus forward attention on the target, or it may be accomplished solely within the modality of echolocation. That is, it may be possible for a dolphin to simply 'hear' the orientation of another dolphin's head by monitoring either the outgoing clicks (TEBP) or the received echoes (EEP). Thus, the traditional 'back and forth' monitor position is not expected. There was no evidence from this study suggesting that dolphins engage in active 'monitoring' behaviors. Changes in head angles appear to move steadily in one direction (i.e., toward closer alignment). It is entirely possible that monitoring of TEBP, EEP and visual monitoring did occur during eavesdropping episodes, but this is impossible to ascertain through observation of the video and audio data alone. These findings do not support the idea that dolphins engage in 'back and forth' monitoring in the wild in relation to the activity of conspecifics, and do not therefore lend support to the suggestion that the monitoring behaviors observed in Xitco *et. al's* (2001) experiments have their roots in 'natural' dolphin monitoring behavior. Alternative explanations (as were outlined in section 2.3.2.6) are then the more likely explanation for the described behaviors.

6.2.3.7 Mental state attribution

As has been discussed in section 2.2.3.2, there is much debate as to whether or not the current research paradigms are capable of allowing scientists to conclude that animals are exhibiting behaviors concomitant with mental state attribution. It was argued that the nature of the hypothesis offered by the researcher, the definition of joint attention being used, and the interpretation of

experimental results all contribute to the ultimate conclusion as to whether or not animals are capable of mental state attribution (i.e., that an animal does attribute mental states like ‘seeing’ to other agents). Many models of joint attention (although *not* the bimodal joint attention model) consider mental state attribution to be a vital component of the model. The results of this study do not shed any light on this debate. It was previously noted that observational reports of joint attention behaviors in animals are far less compelling than tightly-controlled experimental reports for the question of mental state attribution. Using similar arguments to those offered by other researchers, it is possible to conclude both that a) these tests results prove that dolphins *do not* attribute mental states to conspecifics, and that b) these tests results prove that dolphins *do* attribute mental states to conspecifics. Obviously, this diminishes the overall value of these results in offering a solution to this problem. The competing arguments are as follows:

Positive argument: dolphins do attribute mental states to other agents

The results of this study show that dolphins in an ‘eavesdropping scenario’ remain more silent than normal dolphins. Given that the eavesdropping scenario consists of D1 initiating echolocation on the camera, it can be assumed that D2 has then altered his normal echolocation behaviors as a response to the echolocation behavior of D1. Given that D2 then appears to move closer to D1 (in terms of head angle), it can be assumed that D2 is aware of the body and head position of D1. If then the multi-source echoic eavesdropping hypothesis is the reason for the increased echolocation that is seen once D2 is positioned with a close head angle to D1, it can also be assumed that D2 is aware of the impact that echolocation production will have on quality of the echo information that is available. Furthermore, the linear relationship between the length of D1’s echolocation click train, and the silent period observed for D2 before D2 engages echolocation, leads to the conclusion that D2 is altering echolocation behavior in close response to the behavior of D1. Given that D2 appears to change behavior in relation to both the echolocation behavior and swim position of D1, and that this behavior appears to be undertaken to maximize the echo information available to him, it can be argued that D2 may have an intimate awareness of the mental state of ‘hearing’ for D1. D2 must understand that D1 is behaving so as to gain information about the camera (the object) using echolocation. D2 then must understand that D1 must be ‘hearing’ the same object the he himself is hearing – this then explains why D2 aligns heads with D1, and only begins echolocating on the same object once appropriate head angle is achieved.

Negative argument: dolphins do not attribute mental states to other agents

While it is true that D2 appears aware of the behavior of D1 (i.e., the presence of echolocation clicks, and the orientation of D1’s head), and that D2 appears to alter behavior in response to these behaviors, this does not lead to the conclusion that D2 is aware of any mental content for D1. D2’s behavior may be undertaken solely to maximize echo information, with D1 not necessarily considered an agent with mental content, but rather a source of echolocation production. This requires only that D2 read the perceptible behavior of D1 and react to this behavior; it is not necessary to assume that D2 knows that ‘mental states’ (i.e., seeing, hearing) are responsible for this behavior.

In conclusion, I would agree with the claim by Povinelli and Vonk (2006) that “the research paradigms that have been heralded as providing evidence that they (animals) do reason about such mental states, do not, in principle, have the ability to provide evidence that uniquely supports that hypothesis”. Especially for the case of observational research, it is extremely difficult to consider results like these as providing evidence for mind reading. Either of the two arguments offered above are compelling, and because the results here do not allow for an obvious way to distinguish between the strengths of either argument, these results are ultimately not capable of lending support to either claim. It may well be that D2 is aware of D1’s mental states, but examining the results of this study have no way of differentiating between D2’s response to D1’s behavior vs. D1’s mental states. The leap to the conclusion that ‘D2 understands that D1 can hear the camera’ requires a leap of faith that is not supported by the evidence.

6.2.3.8 Theory of Mind

If Theory of Mind is taken to include a set of mental content including ‘beliefs’ and ‘knowledge’ (as is outlined in section 2.2.3.4), then the objections raised for the ‘mental state attribution’ debate (section 6.2.3.7) can apply equally to Theory of Mind. Joint attention experiments on animals have provided no conclusive proof as to a capacity for Theory of Mind in animals, and it is not surprising then that the results of this study can not be used to support a notion of Theory of Mind in dolphins. Only by extrapolating the ‘leap’ to mental state attribution discussed in the previous section to include an additional ‘leap’ to Theory of Mind, can a discussion of Theory of Mind be applied to these results. This would certainly be an over-interpretation of the data at best.

6.2.3.9 Point production, comprehension, and intentional communication

Using the bimodal joint attention model as a jumping off point, an attempt was made to explain the results of dolphin pointing experiments (see section 2.3.2.7). Spontaneous point production comprehension (as suggested by Pack & Herman, 2007) requires a special sensitivity to attention and directional cues. This study found that dolphin in an eavesdropping scenario do indeed behave in ways suggesting that they are sensitive to the attentional states of conspecifics. Although the specifics of the mechanisms involved could not be elaborated upon, it is certainly possible that both ACS and ECS cues are used by a dolphin in order to orient toward an object during a joint attention scenario. It is important in particular to note that TEBP could not be isolated as a cause for D2’s behavior; it is possible that EEP alone is responsible for the ECS. Conclusive evidence is lacking that TEBP is a strong enough cue on its own to allow dolphins to form an analogy between the human pointing gesture and the outgoing echolocation beam, and therefore serve as the basis for their proficiency on object choice tasks using pointing. The objections to this suggestion (as outlined in 2.3.2.7) still stand in light of the results of this study.

Support was found however for the idea that dolphins appear to have a robust sensitivity to the attentional states of conspecifics, and that they may alter behavior in the wild as a result of this

sensitivity. Evidence was found that both ACS and ECS can be appealed to as explanations for dolphins' behavior in this study. The proposal that this robust sensitivity in combination with what captive dolphins involved in object choice tasks have learned about human anatomy, human behavior and test conditions then seems like the most likely explanation for the dolphins' performance for pointing comprehension tasks.

Point production remains, however, does not easily flow from the bimodal joint attention hypothesis. No evidence from this study suggests that dolphins appeared to produce echolocation or other behaviors with the specific purpose of manipulating the attentional states of other dolphins. Echolocation itself is not assumed to be an intentionally communicative act, rather, it is performed exclusively for the perceptual benefit of the sender; this study did not find evidence to question this assumption. Without an intent to manipulate behavior (i.e., without intentionally communicative acts), it is untenable to suggest that echolocation production and bimodal joint attentional are the reasons that dolphins appear to produce the kinds of points observed in the Xitco *et al.* (2001) experiments. Additional explanations must then be sought (see section 2.3.2.7)

6.3 Limitations and strengths of this study

This study represents the first reported attempt to document the behavior of wild dolphins engaging in echoic eavesdropping behaviors involving a target. An ambitious study of this nature involving wild dolphins in the open ocean is fraught with difficulty, and some limitations have been pinpointed:

- An observational study is, by definition, less subject to controls than an experimental study. By virtue of the fact that this study focused on free-swimming wild species in a natural environment, a number of design limitations and possible errors will be present.
- Although all precautions were taken, it is not possible to say with total certainty that the equipment employed was capable of recording all echolocation clicks emitted by the dolphins in question. Click train lengths and echolocation production behavior may not necessarily represent the actual behavior of the dolphins involved. This limitation will always be present in studies involving free-ranging cetaceans.
- Although a great improvement over 'eyeball' estimation methods, the 3D MASC method could not eliminate errors in the estimation of head angle and distance.
- The eavesdropping situation for this study is only one of many possible scenarios that could elicit echoic eavesdropping behaviors in dolphins. It may be that dolphins engaged in foraging, resting, vigilance, threat detection, etc. behave very differently to the situation involving the camera as the target object.

- It is possible that unknown factors (possibly related to the presence of the researchers, boats, equipment, etc.) have drastically altered the echolocation behavior of the animals involved in this study, and that the presence of human observers created a ‘false’ picture of normal dolphin echolocation behavior.

Despite these potential risks, the merits of this study far outweigh potential limitations. For example: 1) data were collected over a period of three years, resulting in large amounts of data from which to choose episodes for codification, 2) rigorous and consistent data collection methodology was applied to both data collection and codification, 3) the dolphins observed in this study consists of a very rare group of habituated wild dolphins, tolerant of human activity in the water, and therefore more likely to engage in natural behavior than most wild populations observed by researchers, 4) a novel method for measuring head angle and distance from underwater video was created, and 5) a novel model of joint attention was presented, discussed, and defended.

6.4 Directions for future research

The results of this study provide some very clear directions for future research investigating both echoic eavesdropping, and the newly proposed multi-source echoic eavesdropping hypothesis. To begin, this study did not find any evidence that close swim proximity was associated with silence (i.e., eavesdropping behavior). Therefore, it is still not certain that a dolphin involved in echoic eavesdropping must remain close to the actively echolocating dolphin in order to receive useful echo information. This is based on the results described here, but also on further ambiguity (discussed in section 2.1) concerning appropriate listening positions, the role of the outgoing click, and the role of off-axis frequencies for echolocation performance. Further tests are required to confirm the distance at which echoic eavesdropping (in terms of object discrimination/detection tasks) can occur. The results of this study suggest that this may in fact occur over much larger distances was proposed and first tested in the Xitco and Roitblat (1996) experiment.

The finding that dolphins are more likely to echolocate when head angles are closer together suggests initial support for the multi-source echoic eavesdropping hypothesis. Given these results, this hypothesis deserves further investigation as it might better explain dolphin swim positions while in a foraging situation than the echoic eavesdropping hypothesis. Or, alternatively, a combination of these two hypotheses may better explain dolphin behavior. Without experimental confirmation as to the potential for summed echolocation click trains to produce ‘better’ object recognition for dolphins, the multi-source echoic eavesdropping hypothesis will remain untested.

Furthermore, the mechanisms discussed in the bimodal joint attention model should be tested to confirm their role in the model. A better understanding of these mechanisms will provide clues as to the basis upon which dolphins appear to understand joint attention and pointing behaviors during

object choice tasks. Specifically, tests could be designed to determine if dolphins have a specific sensitivity to 1) other dolphins' head cues, and 2) other dolphins' body alignment cues. Furthermore, it needs to be determined if dolphins can use the information in the transmitted echolocation beam as an attentional or directional cue. This study suggests that a sensitivity to the outgoing beam is likely closely intertwined with a sensitivity to the generated click echoes, and that a sensitivity to the outgoing beam alone is unlikely to be the mechanism responsible for dolphins' apparent spontaneous comprehension of human pointing gestures.

Testing both the echoic eavesdropping hypothesis and the multi-source echoic eavesdropping hypothesis requires first and foremost considerable experimental work. Knowledge as to what listening positions produce above chance discrimination performance by the listener will be vital to our understanding of the eavesdropping process, and will help resolve questions concerning the role of the outgoing click and off-axis frequencies within the echo process. Testing the multi-source echoic eavesdropping hypothesis will require eavesdropping experiments where the eavesdropper and the investigator are both allowed to inspect an object with echolocation. This type of experiment will determine to what extent multiple echolocation signals hamper or enhance discrimination performance. Perhaps the most straightforward method for testing both effective listening positions and multi-source jamming issues is to use an artificial click projector during a discrimination/detection task involving a single dolphin. By varying the position of the projector in relation to the dolphin, we may learn the importance of on-axis echo reception as it relates to the dolphin's ability to use (artificial) click echoes for object discrimination/detection. The artificial click projector can also be used to investigate a dolphin's ability to perform active echolocation discrimination/detection tasks while being 'jammed' by the projector.

Further studies on wild dolphins are required in order to augment the findings of this study. This study investigated only one possible behavioral scenario wherein echoic eavesdropping may occur. A comprehensive study of dolphin biosonar behavior in terms of foraging, resting, vigilance, etc. is required if we are to begin to unravel the mystery of how echolocation is used by wild dolphins.

6.5 Concluding remarks

A capacity for object discrimination through echoic eavesdropping has been demonstrated (Xitco & Roitblat, 1996), and this study has provided initial support for the hypothesis that echoic eavesdropping may occur in wild dolphins. Many questions remained unanswered however, and this study is likely only the beginning of what is hoped to be a fruitful line of investigation.

References

- Adolphs, R., Russell, J. A., & Tranel, D. (1999). A role for the human amygdala in recognizing emotional arousal from unpleasant stimuli. *Psychological Science, 10*, 167-171.
- Agnetta, B., Hare, B., & Tomasello, M. (2000). Cues to food location that domestic dogs (*Canis familiaris*) of different ages do and do not use. *Animal Cognition, 3*(2), 107-112.
- Aichhorn, M., Perner, J., Kronbichler, M., Staffen, W., & Ladurner, G. (2006). Do visual perspective tasks need theory of mind? *Neuroimage, 30*(3), 1059-1068.
- Akamatsu, T., Wang, D., & Wang, K. X. (2005). Off-axis sonar beam pattern of free-ranging finless porpoises measured by a stereo pulse event data logger. *Journal of the Acoustical Society of America, 117*(5), 3325-3330.
- Altes, R. A. (1995). Signal processing for target recognition in biosonar. *Neural Networks, 8*(7-8), 1275-1295.
- Altes, R. A., Dankiewicz, L. A., Moore, P. W., & Helweg, D. A. (2003). Multiecho processing by an echolocating dolphin. *Journal of the Acoustical Society of America, 114*(2), 1155-1166.
- Altmann, J. (1974). Observational study of behavior: sampling methods. *Behaviour, 49*(3), 227-267.
- Anderson, J. R., Montant, M., & Schmitt, D. (1996). Rhesus monkeys fail to use gaze direction as an experimenter-given cue in an object-choice task. *Behavioural Processes, 37*(47-55).
- Anderson, J. R., Sallaberry, P., & Barbier, H. (1995). Use of experimenter-given cues during object-choice tasks by capuchin monkeys. *Animal Behaviour, 49*(1), 201-208.
- Andersson, M., & Wallander, J. (2004). Kin selection and reciprocity in flight formation? *Behavioral Ecology, 15*, 158-162.
- Anstis, S. M., Mayhew, J. W., & Morley, T. (1969). The Perception of Where a Face or Television 'Portrait' Is Looking. *The American Journal of Psychology, 82*(4), 474-489.
- Au, W. W. L. (1993). *The Sonar of Dolphins*. New York: Springer-Verlag.

- Au, W. W. L. (1994). Comparison of sonar discrimination: Dolphin and an artificial neural network. *The Journal of the Acoustical Society of America*, 95(5), 2728-2735.
- Au, W. W. L. (2003). Echolocation signals of wild dolphins. *Acoustical Physics*, 50(4), 454-462.
- Au, W. W. L., & Hammer, C. E. (1980). Target Recognition via Echolocation by *Tursiops truncatus*. In R. G. Busnel & J. F. Fish (Eds.), *Animal Sonar Systems* (pp. 855-858). New York: Plenum Press.
- Au, W. W. L., Schusterman, R. J., & Kersting, D. A. (1980). Sphere-Cylinder Discrimination via Echolocation by *Tursiops truncatus*. In R. G. Busnel & J. F. Fish (Eds.), *Animal Sonar Systems* (pp. 859-862). New York: Plenum Press.
- Au, W. W. L., & Snyder, K. J. (1980). Long-range target detection in open waters by an echolocating Atlantic Bottlenose dolphin (*Tursiops truncatus*). *Journal of the Acoustical Society of America*, 68, 1077-1084.
- Au, W. W. L., & Turl, C. W. (1991). Material composition discrimination of cylinders at different aspect angles by an echolocating Dolphin. *Journal of the Acoustical Society of America*, 89, 2448-2451.
- Au, W. W. L., & Würsig, B. (2004). Echolocation signals of dusky dolphins (*Lagenorhynchus obscurus*) in Kaikoura, New Zealand. *Journal of the Acoustical Society of America*, 115(5), 2307-2313.
- Au, W. W. L., & Benoit-Bird, K. J. (2003). Automatic gain control in the echolocation system of dolphins. *Nature*, 423(6942), 861-863.
- Au, W. W. L., & Moore, P. W. (1984). Receiving beam patterns and directivity indices of the Atlantic bottlenose dolphin *Tursiops truncatus*. *Journal of the Acoustical Society of America*, 75(1), 255-262.
- Au, W. W. L., Moore, P. W., & Pawloski, D. (1986). Echolocation transmitting beam of the Atlantic bottlenose dolphin. *Journal of the Acoustical Society of America*, 80(2), 688-691.
- Au, W. W. L., Moore, P. W., & Pawloski, D. A. (1988). Detection of complex echoes in noise by an echolocating dolphin. *Journal of the Acoustical Society of America*, 83(2), 662-668.

- Bailey, H., & Lusseau, D. (2004). Increasing the precision of theodolite tracking: modified technique to calculate the altitude of land-based observation sites. *Marine Mammal Science*, 20(4), 880-885.
- Balcombe, J. P., & Fenton, M. B. (1988). Eavesdropping by bats: the influence of echolocation call design and foraging strategy. *Ethology*, 79(2), 158-166.
- Baldwin, D. A., & Baird, J. A. (2001). Discerning intentions in dynamic human action. *Trends in Cognitive Sciences*, 5(4), 171-178.
- Baldwin, D. A., & Moses, L. J. (1996). The Ontogeny of Social Information Gathering. *Child Development*, 67(5), 1915-1939.
- Barclay, R. M. R. (1982). Interindividual use of echolocation calls: eavesdropping by bats. *Behavioral Ecology and Sociobiology*, 10(4), 271-275.
- Barlow, G. W. (1972). The Attitude of Fish Eye-Lines in Relation to Body Shape and to Stripes and Bars. *Copeia*, 1972(1), 4-12.
- Baron-Cohen, S. (1989). Perceptual role taking and protodeclarative pointing in autism. *British Journal of Developmental Psychology* 7(2), 113-127.
- Baron-Cohen, S. (1995). *Mindblindness: An essay on autism and theory of mind*: The MIT Press.
- Baron-Cohen, S. (2000). Theory of mind and autism: A fifteen year review. In S. Baron-Cohen, H. Tager-Flusberg & D. J. Cohen (Eds.), *Understanding other minds: Perspectives from developmental cognitive neuroscience*. Oxford: Oxford University Press.
- Baron-Cohen, S. (2004). The cognitive neuroscience of autism. *Journal of Neurology, Neurosurgery & Psychiatry*, 75(7), 945-948.
- Baron-Cohen, S., Corballis, M. C., & Lea, S. E. G. (1999a). The evolution of a theory of mind. In *The descent of mind: Psychological perspectives on hominid evolution*. (pp. 261-277): Oxford University Press.
- Baron-Cohen, S., & Ring, H. (1994). A model of the mindreading system: Neuropsychological and neurobiological perspectives. In P. C. Lewis & P. Mitchell (Ed.), *Children's Early Understanding of Mind: Origins and Development* (pp. 183-207). Hillsdale, NJ: Erlbaum.

- Baron-Cohen, S., Ring, H., Moriarty, J., Schmitz, B., Costa, D., & Ell, P. (1995). Recognition of mental state terms: clinical findings in children with autism, and a functional imaging study of normal adults. *British Journal of Psychiatry*, *165*, 640-649.
- Baron-Cohen, S., Ring, H. A., Wheelwright, S., Bullmore, E. T., Brammer, M. J., Simmons, A., et al. (1999b). Social intelligence in the normal and autistic brain: an fMRI study. *European Journal of Neuroscience*, *11*(6), 1891-1898.
- Barrett-Lennard, L. G., Ford, J. K. B., & Heise, K. A. (1996). The mixed blessing of echolocation: differences in sonar use by fish-eating and mammal-eating killer whales. *Animal Behaviour*, *51*(3), 553-565.
- Barth, J., Reaux, J. E., & Povinelli, D. J. (2004). Chimpanzees' (*Pan troglodytes*) use of gaze cues in object-choice tasks: different methods yield different results. *Animal Cognition*.
- Bastian, J. (1967). The transmission of arbitrary environmental information between bottlenosed dolphins. In R. G. Busnel (Ed.), *Animal Sonar Systems* (Vol. 2, pp. 803-873). Jouy-en-Josad, France: Laboratoire de Physiologie Acoustique.
- Bates, E. (1979). Intentions, conventions, and symbols. In E. Bates (Ed.), *The emergence of symbols: cognition and communication in infancy* (pp. 33-68). New York: Academic.
- Bates, E., Benigni, L., Bretherton, I., Camaioni, L., & Volterra, V. (1977). From gesture to the first word: On cognitive and social prerequisites. In M. Lewis & L. Rosenblum (Eds.), *Interaction, conversation, and the development of language*. New York: Wiley.
- Bates, E., Camaioni, L., & Volterra, V. (1975). Performatives prior to speech. *Merrill-Palmer Quarterly*, *21*, 205-226.
- Bates, E., O'Connell, B., & Shore, C. (1987). Language and communication in infancy. In J. Osofsky (Ed.), *Handbook of infant development* (pp. 149-203). New York: Wiley.
- Beeching, S. C. (1993). Eyespots as Visual Cues in the Intraspecific Behavior of the Cichlid Fish *Astronotus ocellatus*. *Copeia*, *1993*(4), 1154-1157.
- Bekoff, M., & Jamieson, D. (1996). *Readings in animal cognition*. Cambridge, Mass.: MIT Press.

- Bertrand, M. T. (1969). The behavioural repertoire of the stumptail macaque: a descriptive and comparative study. *Bibliotheca Primatologica*, *11*, 1-273.
- Bradbury, J. W., & Vehrencamp, S. L. (1998). *Principles of Animal Communication*. Sunderland: Sinauer Associates, Inc.
- Brauer, J., Call, J., & Tomasello, M. (2005). All Great Ape Species Follow Gaze to Distant Locations and Around Barriers. *Journal of Comparative Psychology*, *119*(2), 145-154.
- Brauer, J., Kaminski, J., Riedel, J., Call, J., & Tomasello, M. (2006). Making inferences about the location of hidden food: social dog, causal ape. *Journal of Comparative Psychology*, *120*(1), 38-47.
- Britton, N. F., Franks, N. R., Pratt, S. C., & Seeley, T. D. (2002). Deciding on a new home: how do honeybees agree? *Proceedings of the Royal Society B: Biological Sciences*, *269*(1498), 1383-1388.
- Brooks, R., & Meltzoff, A. N. (2005). The development of gaze following and its relation to language. *Developmental Science*, *8*(6), 535-543.
- Bruinsma, Y., Koegel, R. L., & Koegel, L. K. (2004). Joint attention and children with autism: a review of the literature. *Mental Retardation and Developmental Disabilities Research Reviews*, *10*(3), 169-175.
- Buccino, G., Binkofski, F., Fink, G. R., Fadiga, L., Fogassi, L., Gallese, V., et al. (2001). Action observation activates premotor and parietal areas in a somatotopic manner: an fMRI study. *European Journal of Neuroscience*, *13*(2), 400-404.
- Buchholtze, E. A. (2001). Vertebral osteology and swimming style in living and fossil whales (Order: Cetacea). *Journal of Zoology*, *253*, 175-190.
- Bugnyar, T., & Kotrschal, K. (2002). Observational learning and the raiding of food caches in ravens, *Corvus corax*: is it 'tactical' deception? *Animal Behaviour*, *64*(2), 185-195
- Bugnyar, T., Stowe, M., & Heinrich, B. (2004). Ravens, *Corvus corax*, follow gaze direction of humans around obstacles. *Proceedings Biological Sciences*, *271*(1546), 1331-1336.
- Burger, J., Gochfeld, M., & Murray, B. G. (1992). Risk discrimination of eye contact and

- directness of approach in black iguanas (*Ctenosaura similis*). *Journal of Comparative Psychology*, 106, 97-101.
- Butterworth, G. (1995). Origins of mind in perception and action. In C. Moore & P. J. Dunham (Eds.), *Joint attention: Its origins and role in development* (pp. 1-14). Hillsdale, NJ: Erlbaum.
- Butterworth, G. (1998). Origins of joint visual attention in infancy. *Monographs of the Society for Research in Child Development*, 63(4), 144-166.
- Butterworth, G. (2001). Joint visual attention in infancy. In J. G. Bremner & A. Fogel (Eds.), *Blackwell handbook of infant development* (pp. 213–240). Hove: Blackwell.
- Butterworth, G. (2003). Pointing is the royal road to language for babies. In S. Kita (Ed.), *Pointing: Where language, culture, and cognition meet* (pp. 9–33). Mahwah, NJ: Erlbaum.
- Butterworth, G., & Jarrett, N. (1991). What minds have in common in space-spatial mechanisms serving joint visual-attention in infancy. *British Journal of Developmental Psychology*, 9, 55-72.
- Calder, A. J., Lawrence, A. D., Keane, J., Scott, S. K., Owen, A. M., Christoffels, I., et al. (2002). Reading the mind from eye gaze. *Neuropsychologia*, 40(8), 1129-1138.
- Caldwell, D. K., & Caldwell, M. C. (1977). Cetaceans. In T. A. Sebeok (Ed.), *How Animals Communicate* (pp. 794-808). Bloomington: Indiana University Press.
- Call, J. (2001). Chimpanzee social cognition. *Trends in Cognitive Sciences*, 5(9), 388-393.
- Call, J., Brauer, J., Kaminski, J., & Tomasello, M. (2003). Domestic dogs (*Canis familiaris*) are sensitive to the attentional state of humans. *Journal of Comparative Psychology*, 117(3), 257-263.
- Call, J., Hare, B., Carpenter, M., & Tomasello, M. (2004). 'Unwilling' versus 'unable': chimpanzees' understanding of human intentional action. *Developmental Science*, 7(4), 488-498.
- Call, J., Hare, B. A., & Tomasello, M. (1998). Chimpanzee gaze following in an object-choice

task. *Animal Cognition*, 1(2), 89-99.

Call, J., & Tomasello, M. (1994). Production and comprehension of referential pointing by orangutans (*Pongo pygmaeus*). *Journal of Comparative Psychology*, 108(4), 307-317.

Call, J., & Tomasello, M. (1998). Distinguishing intentional from accidental actions in orangutans (*Pongo pygmaeus*), chimpanzees (*Pan troglodytes*), and human children (*Homo sapiens*). *Journal of Comparative Psychology*, 112(2), 192-206.

Carpenter, M., Nagell, K., Tomasello, M., Butterworth, G., & Moore, C. (1998). Social Cognition, Joint Attention, and Communicative Competence from 9 to 15 Months of Age. *Monographs of the Society for Research in Child Development*, 63(4), i-174.

Carpenter, M., Pennington, B. F., & Rogers, S. J. (2001). Understanding of others' intentions in children with autism. *Journal of Autism and Developmental Disorders*, 31(6), 589-599.

Charman, T. (2003). Why is joint attention a pivotal skill in autism? *Philosophical Transactions of the Royal Society B: Biological Sciences*, 358(1430), 315-324.

Charman, T., Baron-Cohen, S., Swettenham, J., Baird, G., Cox, A., & Drew, A. (2000). Testing joint attention, imitation, and play as infancy precursors to language and theory of mind. *Cognitive Development*, 15(4), 481-498.

Cheney, D. L., & Seyfarth, R. M. (1990). *How Monkeys See the World: Inside the Mind of Another Species*. Chicago: University of Chicago Press.

Cole, K. R., & Speakman, J. R. (1993, Nov. 11-15). *Do cetaceans have elevated resting metabolic rates?* Paper presented at the Abstracts Tenth Biennial Conference on the Biology of Marine Mammals, Galveston, TX.

Connor, R. C., & Mann, J. (2006). Social cognition in the wild: Machiavellian dolphins? In S. Hurley & M. Nudds (Eds.), *Rational Animals?* (pp. 329-367). Oxford: Oxford University Press.

Connor, R. C., Smolker, R., & Bejder, L. (2006). Synchrony, social behaviour and alliance affiliation in Indian Ocean bottlenose dolphins, *Tursiops aduncus*. *Animal Behaviour*.

Corkum, V., & Moore, C. (1998). The origins of joint visual attention in infants. *Developmental*

Psychology, 34(1), 28-38.

Coss, R. G. (1978). Perceptual determinants of gaze aversion by the lesser mouse lemur (*Microcerbus murinus*). The role of two facing eyes. *Behaviour*, 64, 248-267.

Coss, R. G. (1979). Delayed plasticity of an instinct: recognition and avoidance of 2 facing eyes by the jewel fish. *Developmental Psychobiology*, 12, 335-345.

Cramer, O. (1993). The variation of the specific heat ratio and the speed of sound in air with temperature, pressure, humidity, and CO₂ concentration. *The Journal of the Acoustical Society of America*, 93(5), 2510-2516.

Cranford, T. W., & Amundin, M. (2004). Biosonar Pulse Production in Odontocetes: The State of Our Knowledge. In J. A. Thomas, C. Moss & M. Vater (Eds.), *Echolocation in bats and dolphins* (pp. 27-35). Chicago: The University of Chicago Press.

Cutting, J. E., & Vishton, P. M. (1995). Perceiving layout and knowing distances: The integration, relative potency, and contextual use of different information about depth. In W. E. Epstein & S. Rogers (Eds.), *Handbook of perception and cognition* (Vol. 5, pp. 69-117). San Diego, CA: Academic Press.

Dankiewicz, L. A., Helweg, D. A., Moore, P. W., & Zafran, J. M. (2002). Discrimination of amplitude-modulated synthetic echo trains by an echolocating bottlenose dolphin. *Journal of the Acoustical Society of America*, 112(4), 1702-1708.

Dawson, G., Munson, J., Estes, A., Osterling, J., McPartland, J., Toth, K., et al. (2002a). Neurocognitive function and joint attention ability in young children with autism spectrum disorder versus developmental delay. *Child Development*, 73(2), 345-358.

Dawson, G., Webb, S., Schellenberg, G. D., Dager, S., Friedman, S., Aylward, E., et al. (2002b). Defining the broader phenotype of autism: genetic, brain, and behavioral perspectives. *Development and Psychopathology*, 14(3), 581-611.

Dawson, S. M. (1991). Clicks and communication: The behavioural and social contexts of Hector's dolphin vocalisations. *Ethology*, 88(4), 265-276.

de Waal, F. B. M. (2000). *Chimpanzee politics: power and sex among apes* (Rev. ed.). Baltimore: Johns Hopkins University Press.

- Deaner, R. O., & Platt, M. L. (2003). Reflexive social attention in monkeys and humans. *Current Biology*, 13(18), 1609-1613.
- Dennett, D. C. (1987). *The intentional stance*. Cambridge, MA: MIT/Bradford Books.
- Dickinson, A., & Balleine, B. W. (2000). Causal cognition and goal-directed action. In C. Heyes & L. Huber (Eds.), *Evolution of cognition* (pp. 85-204). Cambridge, MA: The MIT Press.
- dos Santos, M. E., & Almada, V. C. (2004). A Case for Passive Sonar: Analysis of Click Train Emissions by Bottlenose Dolphins in a Turbid Estuary. In J. A. Thomas, C. Moss & M. Vater (Eds.), *Echolocation in bats and dolphins* (pp. 400-403). Chicago: The University of Chicago Press.
- dos Santos, M. E., Caporin, G., Moreira, H. O., Ferreira, A. J., & Coelho, J. (1990). Acoustic behavior in a local population of bottlenose dolphins. In J. T. R. Kastelein (Ed.), *Sensory Abilities of Cetaceans* (pp. 585-598). New York: Plenum.
- Dubrovsky, N. A. (2004). Echolocation System of the Bottlenose Dolphin. *Acoustical Physics*, 50(3), 305-317
- Dudzinski, K. M., Clark, C. W., & Würsig, B. (1995). A mobile video/acoustic system for simultaneous recording underwater recording of dolphin interactions *Aquatic Mammals*, 21(3), 187-193.
- Dudzinski, K. M., Sakai, M., Masaki, K., Kogi, K., Hishii, T., & Kurimoto, M. (2003). Behavioural observations of bottlenose dolphins towards two dead conspecifics. *Aquatic Mammals*, 29(1), 108-116.
- Dunham, P., & Dunham, F. (1992). Lexical Development During Middle Infancy : A Mutually Driven Infant - Caregiver Process. *Developmental Psychology*, 28(3), 414-420.
- Eacott, M. J., Heywood, C. A., Gross, C. G., & Cowey, A. (1993). Visual discrimination impairments following lesions of the superior temporal sulcus are not specific for facial stimuli. *Neuropsychologia*, 31(6), 609-619.
- Emery, N. (2005). The evolution of social cognition. In A. Easton & N. Emery (Eds.), *The cognitive neuroscience of social behaviour*. Hove; New York: Psychology Press.

- Emery, N., Dally, J., & Clayton, N. (2004). Western scrub-jays (*Aphelocoma californica*) use cognitive strategies to protect their caches from thieving conspecifics. *Animal Cognition*, 7(1), 37-43.
- Emery, N. J. (2000). The eyes have it: the neuroethology, function and evolution of social gaze. *Neuroscience & Biobehavioral Reviews*, 24(6), 581-604.
- Emery, N. J., Lorincz, E. N., Perrett, D. I., Oram, M. W., & Baker, C. I. (1997). Gaze Following and Joint Attention in Rhesus Monkeys (*Macaca mulatta*). *Journal of Comparative Psychology*, 111(3), 286-293.
- Evans, W. E., & Awbrey, F. T. (1988). Natural history aspects of marine mammal echolocation: feeding strategies and habitat. In P. E. Nachtigall & P. W. B. Moore (Eds.), *Animal Sonar: Processes and Performance* (pp. 521-534). New York: Plenum Press.
- Fagot, J., & Deruelle, C. (2002). Perception of pictorial eye gaze by baboons (*Papio papio*). *Journal of Experimental Psychology-Animal Behavior Processes*, 28(3), 298-308.
- Fellner, W., Bauer, G. B., & Harley, H. E. (2006). Cognitive Implications of Synchrony in Dolphins: A Review. *Aquatic Mammals*, 32(4), 511-516.
- Fenton, M. B. (1980). Adaptiveness and ecology of echolocation in terrestrial (aerial) systems. In R. G. Busnel & J. F. Fish (Eds.), *Animal Sonar Systems* (pp. 427-448). New York: Plenum Press.
- Fenton, M. B. (2003). Eavesdropping on the echolocation and social calls of bats. *Mammal Review*, 33(3-4), 193-204.
- Ferrari, P. F., Kohler, E., Fogassi, L., & Gallese, V. (2000). The ability to follow eye gaze and its emergence during development in macaque monkeys. *Proceedings of the National Academy of Sciences of the United States of America*, 97(25), 13997-14002.
- Fine, C., Lumsden, J., & Blair, J. R. (2001). Dissociation between 'theory of mind' and executive functions in a patient with early left amygdala damage. *Brain*, 124, 287-298.
- Flanagan, J. R., & Johansson, R. S. (2003). Action plans used in action observation. *Nature*, 424, 769-771.

- Flombaum, J. I., & Santos, L. R. (2005). Rhesus Monkeys Attribute Perceptions to Others. *Current Biology*, *15*(5), 447-452.
- Fogassi, L., Ferrari, P. F., Gesierich, B., Rozzi, S., Chersi, F., & Rizzolatti, G. (2005). Parietal lobe: from action organization to intention understanding. *Science*, *308*(5722), 662-667.
- Franco, F., & Butterworth, G. (1996). Pointing and social awareness: declaring and requesting in the second year. *Journal of Child Language*, *23*(2), 307-336.
- Frith, U., & Frith, C. (2001). The biological basis of social interaction. *Current Directions in Psychological Science*, *10*, 151-155.
- Gallup, G. G. (1970). Chimpanzees: self-recognition. *Science*, *167*, 86-87.
- Gallup, G. G., Cummings, W. H., & Nash, R. F. (1972). The experimenter as an independent variable in studies of animal hypnosis in chickens (*Gallus gallus*). *Animal Behaviour*, *20*, 166-169.
- Gannon, D. P., Barros, N. B., Nowacek, D. P., Read, A. J., Waples, D. M., & Wells, R. S. (2005). Prey detection by bottlenose dolphins, *Tursiops truncatus*: an experimental test of the passive listening hypothesis. *Animal Behaviour*, *69*, 709-720.
- Gillam, E. H., Ulanovsky, N., & McCracken, G. F. (2007). Rapid jamming avoidance in biosonar. *Proceedings of the Royal Society B: Biological Sciences*, *274*, 651-660.
- Gomez, J. C. (1991). Visual behaviour as a window for reading the mind of others in primates. In A. Whiten (Ed.), *Natural Theories of Mind: Evolution, Development and Simulation of Everyday Mindreading* (pp. 195-207). Oxford: Basil Blackwell.
- Gopnik, A., Slaughter, V., & Meltzoff, A. N. (1994). Changing your views: how understanding visual perception can lead to a new theory of the mind. In C. L. a. P. Mitchell (Ed.), *Children's Early Understanding of Mind: Origins and Development* (pp. 157-181). Hillsdale, NJ: Lawrence Erlbaum Associates Inc.
- Götz, T., Verfuß, U. K., & Schnitzler, H.-U. (2005). 'Eavesdropping' in wild rough-toothed dolphins (*Steno bredanensis*)? *Biology Letters*, *2*(1), 5-7.

- Gregg, J. D., Dudzinski, K. M., & Smith, H. V. (2007). Do dolphins eavesdrop on the echolocation signals of conspecifics? . *International Journal of Comparative Psychology*, 20, 65-88.
- Grezes, J., Frith, C. D., & Passingham, R. E. (2004). Inferring false beliefs from the actions of oneself and others: an fMRI study. *Neuroimage*, 21(2), 744-750.
- Haith, M. M., Bergman, T., & Moore, M. J. (1977). Eye contact and face scanning in early infancy. *Science*, 198(4319), 853-855.
- Hare, B., Agnetta, B., & Tomasello, M. (2000). Chimpanzees know what conspecifics do and do not see. *Animal Behaviour*, 59, 771-785.
- Hare, B., Brown, M., Williamson, C., & Tomasello, M. (2002). The domestication of social cognition in dogs. *Science*, 298(5598), 1634-1636.
- Hare, B., Call, J., & Tomasello, M. (1998). Communication of food location between human and dog (*Canis familiaris*). *Evolution of Communication*, 2, 137-159.
- Hare, B., Call, J., & Tomasello, M. (2001). Do chimpanzees know what conspecifics know? *Animal Behaviour*, 61, 139-151.
- Hare, B., & Tomasello, M. (2004). Chimpanzees are more skillful in competitive than cooperative cognitive tasks. *Animal Behaviour*, 68, 571-581.
- Harley, H. E., Putman, E. A., & Roitblat, H. L. (2003). Bottlenose dolphins perceive object features through echolocation. *Nature*, 424(6949), 667-669.
- Harley, H. E., Roitblat, H. L., & Nachtigall, P. E. (1996). Object representation in the bottlenose dolphin (*Tursiops truncatus*): integration of visual and echoic information. *Journal of Experimental Psychology: Animal Behavior Processes*, 22(2), 164-174.
- Harley, R. W., Xitco, M. J., & Roitblat, H. L. (1995). Echolocation, cognition, and the dolphin's world. In R. A. Kastelein, J. A. Thomas & P. E. Nachtigall (Eds.), *Sensory Systems of Aquatic Mammals* (pp. 529-537). Woerden: DeSpil Publishers.
- Heinrich, B., & Pepper, J. (1998). Influence of competitors on caching behaviour in the common raven, *Corvus corax*. *Animal Behaviour*, 56(5), 1083-1090.

- Helweg, D. A., Au, W. W. L., Roitblat, H. L., & Nachtigall, P. E. (1996a). Acoustic basis for recognition of aspect-dependent three-dimensional targets by an echolocating bottlenose dolphin. *Journal of the Acoustical Society of America*, *99*(4 Pt 1), 2409-2420.
- Helweg, D. A., Moore, P. W., Dankiewicz, L. A., Zafran, J. M., & Brill, R. L. (2003). Discrimination of complex synthetic echoes by an echolocating bottlenose dolphin. *Journal of the Acoustical Society of America*, *113*(2), 1138-1144.
- Helweg, D. A., Roitblat, H. L., Nachtigall, P. E., & Hautus, M. J. (1996b). Recognition of aspect-dependent three-dimensional objects by an echolocating Atlantic bottlenose dolphin. *Journal of Experimental Psychology: Animal Behavior Processes*, *22*(1), 19-31.
- Henderson, L. M., Yoder, P. J., Yale, M. E., & McDuffie, A. (2002). Getting the point: electrophysiological correlates of protodeclarative pointing. *International Journal of Developmental Neuroscience*, *20*(3-5), 449-458.
- Hennig, C. W. (1977). Effect of simulated predation on tonic immobility in *Anolis carolinensis*: The role of eye contact. *Bulletin of the Psychonomic Society*, *9*, 239-242.
- Herald, E. S., Brownell, R. L., Jr., Frye, F. L., Morris, E. J., Evans, W. E., & Scott, A. B. (1969). Blind river dolphin: first side-swimming cetacean. *Science*, *166*(911), 1408-1410.
- Herman, L., Pack, A. A., & Morrel-Samuels, P. (1993). Representational and Conceptual Skills of Dolphins. In H. L. Roitblat, L. M. Herman & P. E. Nachtigall (Eds.), *Language and Communication: Comparative Perspectives*. Hillsdale, NJ: Lawrence Erlbaum Associates.
- Herman, L. M. (2006a). Intelligence and rational behaviour in the bottle-nosed dolphin. In S. Hurley & M. Nudds (Eds.), *Rational Animals?* (pp. 439-467). Oxford: Oxford University Press.
- Herman, L. M. (2006b). Intelligence and rational behaviour in the bottlenosed dolphin. In S. Hurley & M. Nudds (Eds.), *Rational Animals?* (pp. 439-467). Oxford: Oxford university Press.
- Herman, L. M., Abichandani, S. L., Elhajj, A. N., Herman, E. Y. K., Sanchez, J. L., & Pack, A. A. (1999). Dolphins (*Tursiops truncatus*) comprehend the referential character of the human pointing gesture. *Journal of Comparative Psychology*, *113*(4), 347-364.

- Herman, L. M., P.H. Forestell. (1985). Reporting presence or absence of named objects by a language-trained dolphin. *Neuroscience & Biobehavioral Reviews*, 9, 667-681.
- Herman, L. M., & Pack, A. A. (1992). Echoic-visual cross-modal recognition by a dolphin. In J. A. Thomas, R. A. Kastelein & A. Y. Supin (Eds.), *Marine Mammal Sensory Systems* (pp. 709-726). New York: Plenum.
- Herman, L. M., Pack, A. A., & Hoffmann-Kuhnt, M. (1998). Seeing Through Sound: Dolphins (*Tursiops truncatus*) Perceive the Spatial Structure of Objects Through Echolocation. *Journal of Comparative Psychology*, 112(3), 292-305.
- Herman, L. M., & Tavalga, W. N. (1980). The communication systems of cetaceans. In L. M. Herman (Ed.), *Cetacean Behavior* (pp. 149-209). New York: John Wiley & Sons.
- Herman, L. M., & Uyeyama, R. U. (1999). The Dolphin's Grammatical Competency: Comments on Kako *Animal Learning and Behavior* 27(1), 18-23.
- Hersh, S. L., Odell, D. K., & Asper, E. D. (1990). Sexual dimorphism in bottlenose dolphins from the east coast of Florida. *Marine Mammal Science*, 6(4), 305.
- Herzing, D. L. (2000). Acoustics and Social Behavior of Wild Dolphins: Implications for a Sound Society In W. L. Whitlow, A. N. Popper & R. R. Fay (Eds.), *Hearing by Whales and Dolphins* (pp. 225-272). New York: Springer.
- Herzing, D. L. (2004). Social and Nonsocial Uses of Echolocation in Free-Ranging *Stenella frontalis* and *Tursiops truncatus*. In J. A. Thomas, C. Moss & M. Vater (Eds.), *Echolocation in bats and dolphins* (pp. 404-409). Chicago: The University of Chicago Press.
- Herzing, D. L. (2006). The Currency of Cognition: Assessing Tools, Techniques, and Media for Complex Behavioral Analysis. *Aquatic Mammals*, 32(4), 544-553.
- Herzing, D. L., & dos Santos, M. E. (2004). Functional Aspects of Echolocation in Dolphins. In J. A. Thomas, C. Moss & M. Vater (Eds.), *Echolocation in bats and dolphins* (pp. 386-392). Chicago: The University of Chicago Press.
- Hess, J., Novak, M. A., & Povinelli, D. J. (1993). 'Natural pointing' in a rhesus monkey, but no

evidence of empathy. *Animal Behaviour*, 46, 1023-1025.

Hinde, R. A., & Rowell, T. E. (1961). Communication by postures and facial expression in the rhesus monkey (*Macaca mulatta*). *Symposia of the Zoological Society of London*, 8, 1-21.

Hirata, S., & Matsuzawa, T. (2001). Tactics to obtain a hidden food item in chimpanzee pairs (*Pan troglodytes*). *Animal Cognition*, 4(3 - 4), 285-295.

Hockett, C. F. (1960). The origin of speech. *Scientific American*, 203, 89-96.

Hoffman, M. W., Grimes, D. B., Shon, A. P., & Rao, R. P. (2006). A probabilistic model of gaze imitation and shared attention. *Neural Networks*, 19(3), 299-310.

Hooker, C. I., Paller, K. A., Gitelman, D. R., Parrish, T. B., Mesulam, M. M., & Reber, P. J. (2003). Brain networks for analyzing eye gaze. *Cognitive Brain Research*, 17(2), 406-418.

Horton, K. E., & Caldwell, C. A. (2006). Visual co-orientation and expectations about attentional orientation in pileated gibbons (*Hylobates pileatus*). *Behavioural Processes*, 72(1), 65-73.

Houser, D., Martin, S. W., Bauer, E. J., Phillips, M., Herrin, T., Cross, M., et al. (2005). Echolocation characteristics of free-swimming bottlenose dolphins during object detection and identification. *Journal of the Acoustical Society of America*, 117(4 Pt 1), 2308-2317.

Houser, D. S., Helweg, D. A., & Moore, P. W. (1999). Classification of dolphin echolocation clicks by energy and frequency distributions. *Journal of the Acoustical Society of America*, 106(3), 1579-1585.

Hudson, D. (2004). *Working pointers and setters*: Swanhill Press.

Inoue-Nakamura, N., & Matsuzawa, T. (1997). Development of stone tool use by wild chimpanzees (*Pan troglodytes*). *Journal of Comparative Psychology*, 111, 159-173.

Inoue, Y., Inoue, E., & Itakura, S. (2004). Use of experimenter-given directional cues by a young white-handed gibbon (*Hylobates lar*). *Japanese Psychological Research*, 46(3), 262-267.

Itakura, S. (1996). An exploratory study of gazemonitoring in nonhuman primates. *Japanese*

Psychological Research, 38, 174–180.

Itakura, S. (2004). Gaze-following and joint visual attention in nonhuman animals. *Japanese Psychological Research*, 46(3), 216-226.

Itakura, S., Agnetta, B., Hare, B., & Tomasello, M. (1999). Chimpanzee use of human and conspecific social cues to locate hidden food. *Developmental Science*, 2, 448–456.

Itakura, S., & Anderson, J. R. (1996). Learning to use experimenter-given cues during an object-choice task by a capuchin monkey. *Cahiers de psychologie cognitive* 15(1), 103-112.

Itakura, S., & Tanaka, M. (1998). Use of experimenter-given cues during object-choice tasks by chimpanzees (*Pan troglodytes*), an orangutan (*Pongo pygmaeus*), and human infants (*Homo sapiens*). *Journal of Comparative Psychology*, 112(2), 119-126.

Janik, V. (2005). Underwater acoustic communication networks in marine mammals. In P. K. McGregor (Ed.), *Animal Communication Networks* (pp. 390-415). New York: Cambridge University Press.

Janik, V. M. (2000). Food-related bray calls in wild bottlenose dolphins (*Tursiops truncatus*). *Proceedings of the Royal Society of London, B*, 267, 923-927.

Janik, V. M., Sayigh, L. S., & Wells, R. S. (2006). Signature whistle shape conveys identity information to bottlenose dolphins. *Proceedings of the National Academy of Sciences of the United States of America*, 103(21), 8293-8297.

Jaquet, N. (2006). A simple photogrammetric technique to measure sperm whales at sea. *Marine Mammal Science*, 22(4), 862-879.

Jeannerod, M. (1994). The representing brain. Neural correlates of motor intention and imagery. *Behavioral and Brain Sciences*, 17, 187–245.

Jerison, H. J. (1986). The perceptual worlds of dolphins. In R. J. Schusterman, J. A. Thomas & F. G. Wood (Eds.), *Dolphin cognition and behavior: a comparative approach* (pp. 141-166). Hillsdale NJ: Erlbaum.

Johnson, C. M., & Norris, K. S. (1986). Delphinid social organization and social behavior. In R.

- J. Schusterman, J. A. Thomas & F. G. Wood (Eds.), *Dolphin cognition and behavior: A comparative approach* (pp. 335-343). Hillsdale, N.J.: Lawrence Erlbaum Associates.
- Johnson, C. M., & Norris, K. S. (1994). Social Behavior. In K. S. Norris, B. Würsig, R. S. Wells & M. Würsig (Eds.), *The Hawaiian Spinner Dolphin* (pp. 243–286). Berkeley: University of California Press.
- Johnson, C. S. (1988). A brief history of bionic sonar. In P. E. Nachtigall & P. W. B. Moore (Eds.), *Animal Sonar: Processes and Performance* (pp. 769-771). New York: Plenum Press.
- Johnson, R. A. (1980). Energy spectrum analysis in echolocation. In R. G. Busnel & J. F. Fish (Eds.), *Animal sonar systems* (pp. 673-693). New York: Plenum.
- Jones, R. B. (1980). Reactions of male domestic chicks to two-dimensional eye-like shapes. *Animal Behaviour*, 28, 212-218.
- Kakuda, T., Tajima, Y., Arai, K., Kogi, K., Hishii, T., & Yamada, T. K. (2002). On the resident "Bottlenose Dolphins" from Mikura Water. *Memorandum of the Natural Science Museum of Tokyo*, 38, 255-272.
- Kaminski, J., Call, J., & Tomasello, M. (2004). Body orientation and face orientation: two factors controlling apes' behavior from humans. *Animal Cognition*, 7(4), 216-223.
- Kaminski, J., Riedel, J., Call, J., & Tomasello, M. (2005). Domestic goats, *Capra hircus*, follow gaze direction and use social cues in an object choice task. *Animal Behaviour*, 69, 11-18.
- Kaplan, G., & Rogers, L. J. (2002). Patterns of gazing in orangutans (*Pongo pygmaeus*). *International Journal of Primatology*, 23, 501-526.
- Karin-D' Arcy, M. R., & Povinelli, D. J. (2002). Do Chimpanzees Know What Each Other See? A Closer Look
International Journal of Comparative Psychology, 15(1), 21-54.
- Kawashima, R., Sugiura, M., Kato, T., Nakamura, A., Hatano, K., Ito, K., et al. (1999). The human amygdala plays an important role in gaze monitoring. A PET study. *Brain*, 122 (Pt 4), 779-783.

- Kellogg, W. N. (1970). *Porpoises and Sonar*. Chicago: University of Chicago Press.
- Kellogg, W. N., Kohler, R., & Morris, H. N. (1953). Porpoise Sounds as Sonar Signals. *Science*, *117*(3036), 239-243.
- Kingstone, A., Friesen, C. K., & Gazzaniga, M. S. (2000). Reflexive joint attention depends on lateralized cortical connections. *Psychological Science*, *11*(2), 159-166.
- Kingstone, A., Tipper, C., Ristic, J., & Nganb, E. (2004). The eyes have it!: An fMRI investigation. *Brain and Cognition*, *55*, 269-271.
- Kobayashi, H., & Kohshima, S. (1997). Unique morphology of the human eye. *Nature*, *387*(6635), 767-768.
- Kogi, K., Hishi, T., Imamura, A., Iwatani, T., & Dudzinski, K. M. (2004). Demographic Parameters of Indo-Pacific Bottlenose Dolphins (*Tursiops aduncus*) around Mikura Island, Japan. *Marine Mammal Science*, *20*(3), 510-526.
- Kohler, E., Keysers, C., Umiltà, M. A., Fogassi, L., Gallese, V., & Rizzolatti, G. (2002). Hearing sounds, understanding actions: action representation in mirror neurons. *Science*, *297*(5582), 846-848.
- Krause, M. A., & Fouts, R. S. (1997). Chimpanzee (*Pan troglodytes*) pointing: hand shapes, accuracy, and the role of eye gaze. *Journal of Comparative Psychology*, *111*(4), 330-336.
- Kuc, R. (2002). Object localization from acoustic emissions produced by other sonars (L). *Journal of the Acoustical Society of America*, *112*(5), 1753-1755.
- Kuczaj, S. A., & Highfill, L. E. (2005). Dolphin play: Evidence for cooperation and culture? *Behavioral and Brain Sciences*, *28*(5), 705-706.
- Kuhlmeier, V. A., & Birch, S. A. J. (2005). Steps toward categorizing motivation: Abilities, limitations, and conditional constraints. *Behavioral and Brain Sciences*, *28*(5), 706-707.
- Kumashiro, M., Ishibashi, H., Itakura, S., & Iriki, A. (2002). Bidirectional communication between a Japanese monkey and a human through eye gaze and pointing. *Cahiers De Psychologie Cognitive-Current Psychology of Cognition*, *21*(1), 3-32.

- Kumashiro, M., Ishibashi, H., Uchiyama, Y., Itakura, S., Murata, A., & Iriki, A. (2003). Natural imitation induced by joint attention in Japanese monkeys. *International Journal of Psychophysiology*, 50(1-2), 81-99.
- Lammers, M. O., Au, W. W. L., Aubauer, R., & Nachtigall, P. E. (2004). A Comparative Analysis of the Pulsed Emissions of Free-Ranging Hawaiian Spinner Dolphins (*Stenella longirostris*). In J. A. Thomas, C. Moss & M. Vater (Eds.), *Echolocation in bats and dolphins* (pp. 414-419). Chicago: The University of Chicago Press.
- Lammers, M. O., Schotten, M., & Au, W. W. L. (2006). The spatial context of free-ranging Hawaiian spinner dolphins (*Stenella longirostris*) producing acoustic signals. *The Journal of the Acoustical Society of America*, 119(2), 1244-1250.
- Langton, S. R. H. (2000). The mutual influence of gaze and head orientation in the analysis of social attention direction. *The Quarterly Journal of Experimental Psychology A*, 53, 825-845.
- Langton, S. R. H., Watt, R. J., & Bruce, V. (2000). Do the eyes have it? Cues to the direction of social attention. *Trends in Cognitive Sciences*, 4(2), 50-59.
- Leavens, D. A. (2004a). Book review of S. Kita (Ed.), *Pointing: Where language, culture and cognition meet*, Lawrence Erlbaum Associates, 2003. *Cognitive Systems Research*, 5, 157-165.
- Leavens, D. A. (2004b). Manual deixis in apes and humans. *Interaction Studies*, 5, 387-408.
- Leavens, D. A., & Hopkins, W. D. (1998). Intentional communication by chimpanzees: a cross-sectional study of the use of referential gestures. *Developmental Psychology*, 34(5), 813-822.
- Leavens, D. A., & Hopkins, W. D. (1999). The whole-hand point: the structure and function of pointing from a comparative perspective. *Journal of Comparative Psychology*, 113(4), 417-425.
- Leavens, D. A., Hopkins, W. D., & Bard, K. A. (1996). Indexical and referential pointing in chimpanzees (*Pan troglodytes*). *Journal of Comparative Psychology*, 110(4), 346-353.
- Leavens, D. A., Hopkins, W. D., & Bard, K. A. (2005). Understanding the point of chimpanzee

- pointing: Epigenesis and ecological validity. *Current Directions in Psychological Science*, *14*, 185-189.
- Leavens, D. A., Hopkins, W. D., & Thomas, R. K. (2004). Referential communication by chimpanzees (*Pan troglodytes*). *Journal of Comparative Psychology*, *118*(1), 48-57.
- Leonard, C. M., Rolls, E. T., Wilson, F. A. W., & Baylis, G. C. (1985). Neurons in the amygdala of the monkey with responses selective for faces. *Behavioural and Brain Research*, *15*, 159-176.
- Leslie, A. M. (1994). ToMM, ToBy, and Agency: Core architecture and domain specificity. In L. A. Hirschfeld & S. A. Gelman (Eds.), *Mapping the mind: domain specificity in cognition and culture*.
- Li, S. H., Wang, K. X., Wang, D., & Akamatsu, T. (2005). Echolocation signals of the free-ranging Yangtze finless porpoise (*Neophocaena phocaenoides asiaeorientalis*). *Journal of the Acoustical Society of America*, *117*(5), 3288-3296.
- Liszkowski, U., Carpenter, M., Henning, A., Striano, T., & Tomasello, M. (2004). Twelve-month-olds point to share attention and interest. *Developmental Science*, *7*(3), 297-307.
- Lord, C., Risi, S., Lambrecht, L., Cook, E. H., Jr., Leventhal, B. L., DiLavore, P. C., et al. (2000). The autism diagnostic observation schedule-generic: a standard measure of social and communication deficits associated with the spectrum of autism. *Journal of Autism and Developmental Disorders*, *30*(3), 205-223.
- Madsen, P. T., Kerr, I., & Payne, R. (2004). Echolocation clicks of two free-ranging, oceanic delphinids with different food preferences: false killer whales *Pseudorca crassidens* and Risso's dolphins *Grampus griseus*. *The Journal of Experimental Biology*, *207*, 1811-1823.
- Malle, B. F., Moses, L. J., & Baldwin, D. A. (2001). *Intentions and intentionality : foundations of social cognition*. Cambridge, Mass.: MIT Press.
- Mann, J. (1999). Behavioral sampling for cetaceans: A review and critique. *Marine Mammal Science*, *15*(1), 102-122.
- Manser, M., Cheney, D. L., & Seyfarth, R. M. (2002). Suricate alarm calls signal predator class and urgency. *TRENDS in Cognitive Sciences*, *6*(2), 55-57.

- Martin, S. W., Phillips, M., Bauer, E. J., Moore, P. W., & Houser, D. S. (2005). Instrumenting free-swimming dolphins echolocating in open water. *Journal of the Acoustical Society of America*, *117*(4 Pt 1), 2301-2307.
- Masters, W. M., & Harley, H. E. (2004). Performance and Cognition in Echolocating Mammals. In J. A. Thomas, C. Moss & M. Vater (Eds.), *Echolocation in bats and dolphins* (pp. 249-259). Chicago: The University of Chicago Press.
- Maurer, D. (1985). Infants' perception of facedness. In T. Field & N. Fox (Eds.), *Social Perception in Infants*: Ablex.
- McGregor, P. K. (1993). Signalling in Territorial Systems: A Context for Individual Identification, Ranging and Eavesdropping. *Philosophical Transactions: Biological Sciences*, *340*(1292, The Evolution and Design of Animal Signalling Systems), 237-244.
- McGregor, P. K. (2005). *Animal Communication Networks*. New York: Cambridge University Press.
- McKinley, J., & Sambrook, T. D. (2000). Use of human-given cues by domestic dogs (*Canis familiaris*) and horses (*Equus caballus*). *Animal Cognition*, *3*(1), 13-22.
- Meltzoff, A. N. (1995). Understanding the intentions of others: re-enactment of intended acts by 18-month-old children. *Developmental psychology*, *31*(5), 838-850
- Meltzoff, A. N., Brooks, R., Malle, B. F., Moses, L. J., & Baldwin, D. A. (2001). 'Like me' as a building block for understanding other minds: Bodily acts, attention, and intention. In *Intentions and intentionality: Foundations of social cognition*. (pp. 171-191): The MIT Press.
- Mennill, D. J., Ratcliffe, L. M., & Boag, P. T. (2002). Female eavesdropping on male song contests in songbirds. *Science*, *296*(5569), 873.
- Menzel, E. W. (1974). A group of young chimpanzees in a one-acre field: leadership and communication. In A. M. Schrier & F. Stollnitz (Eds.), *Behavior of Nonhuman Primates* (pp. 83-153). New York: Academic Press.
- Miklósi, Á., A. Polgárdi, Topál, J., & Csányi, V. (2000). Intentional behaviour in dog-human

- communication: an experimental analysis of "showing" behaviour in the dog. *Animal Cognition*, 3(3), 159-166.
- Miklósi, Á., Polgárdi, R., Topál, J., & Csányi, V. (1998). Use of experimenter-given cues in dogs. *Animal Cognition*, 1(2), 113-121.
- Miklósi, Á., Pongracz, P., Lakatos, G., Topal, J., & Csanyi, V. (2005). A comparative study of the use of visual communicative signals in interactions between dogs (*Canis familiaris*) and humans and cats (*Felis catus*) and humans. *Journal of Comparative Psychology*, 119(2), 179-186.
- Miklósi, Á., & Soproni, K. (2006). A comparative analysis of animals' understanding of the human pointing gesture. *Animal Cognition*, 9(2), 81-93.
- Moll, H., & Tomasello, M. (2004). 12- and 18-month-old infants follow gaze to spaces behind barriers. *Developmental Science*, 7(1), F1-9.
- Moore, C. (1998). Social cognition in infancy. *Monographs of the Society for Research in Child Development*, 63(4), 167-174.
- Moore, C., & Corkum, V. (1994). Social understanding at the end of the first year of life. *Developmental Review*, 14, 349-372.
- Moore, P. W., Finneran, J., & Houser, D. S. (2004). Hearing loss and echolocation signal change in dolphins. *The Journal of the Acoustical Society of America*, 116(4), 2503-2503.
- Moore, P. W. B. (1980). Cetacean Obstacle Avoidance. In R. G. Busnel & J. F. Fish (Eds.), *Animal Sonar Systems* (pp. 97-108). New York: Plenum Press.
- Moore, P. W. B., Hall, R. W., Friedl, W. A., & Nachtigall, P. E. (1984). The critical interval in dolphin echolocation: What is it? *Journal of the Acoustical Society of America*, 76(1), 314-317.
- Morales, M., Mundy, P., Delgado, C. E. F., Yale, M., Messinger, D., Neal, R., et al. (2000). Responding to Joint Attention Across the 6- Through 24-Month Age Period and Early Language Acquisition. *Journal of Applied Developmental Psychology*, 21(3), 283-298.
- Morales, M., Mundy, P., & Rojas, J. (1998). Following the direction of gaze and language

development in 6-month-olds. *Infant Behavior and Development*, 21(2), 373-377.

Morisaka, T., Shinohara, M., Nakahara, F., & Akamatsu, T. (2005a). Effects Of Ambient Noise On The Whistles Of Indo-Pacific Bottlenose Dolphin Populations. *Journal of Mammalogy*, 86(3), 541-546.

Morisaka, T., Shinohara, M., Nakahara, F., & Akamatsu, T. (2005b). Geographic variations in the whistles among three Indo-Pacific bottlenose dolphin *Tursiops aduncus* populations in Japan. *Fisheries Science*, 71, 568-576.

Morissette, P., Ricard, M., & Decarie, T. G. (1995). Joint visual attention and pointing in infancy: a longitudinal study of comprehension. *British Journal of Developmental Psychology*, 13, 163-177.

Mosconi, M. W., Mack, P. B., McCarthy, G., & Pelphrey, K. A. (2005). Taking an "intentional stance" on eye-gaze shifts: a functional neuroimaging study of social perception in children. *Neuroimage*, 27(1), 247-252.

Mundy, P., Sigman, M., Ungerer, J., & Sherman, T. (1986). Defining the social deficits of autism: the contribution of non-verbal communication measures. *Journal of Child Psychology and Psychiatry*, 27(5), 657-669.

Nachtigall, P. E. (1980). Odontocete Echolocation Performance on Object Size, Shape and Material. In R. G. Busnel & J. F. Fish (Eds.), *Animal Sonar Systems* (pp. 71-95). New York: Plenum Press.

Neiworth, J. J., Burman, M. A., Basile, B. M., & Lickteig, M. T. (2002). Use of experimenter-given cues in visual co-orienting and in an object-choice task by a new world monkey species, cotton top tamarins (*Saguinus oedipus*). *Journal of Comparative Psychology*, 116(1), 3-11.

NewLeap-Ltd. (2000). ECD1 Data Sheet. <http://www.newleap.com/>; NewLeap Ltd.

Norris, D. K., & Dohl, T. P. (1980). The Structure and function of cetacean schools. In L. M. Herman (Ed.), *Cetacean Behavior* (pp. 211-261). New York: John Wiley & Sons.

Norris, K. S., Würsig, B., Wells, R. S., & Würsig, M. (1994). *The Hawaiian Spinner Dolphin*. Berkeley: University of California Press.

- Pack, A. A., & Herman, L. (1996). Dolphins can immediately recognize complex shapes across the senses of echolocation and vision *The Journal of the Acoustical Society of America* 100(4), 2610.
- Pack, A. A., & Herman, L. M. (1995). Sensory integration in the bottlenosed dolphin: immediate recognition of complex shapes across the senses of echolocation and vision. *Journal of the Acoustical Society of America*, 98(2 Pt 1), 722-733.
- Pack, A. A., & Herman, L. M. (2004). Bottlenosed dolphins (*Tursiops truncatus*) comprehend the referent of both static and dynamic human gazing and pointing in an object-choice task. *Journal of Comparative Psychology*, 118(2), 160-171.
- Pack, A. A., & Herman, L. M. (2006). Dolphin Social Cognition and Joint Visual Attention: Our Current Understanding. *Aquatic Mammals*, 32(4).
- Pack, A. A., & Herman, L. M. (2007). The Dolphin's (*Tursiops truncatus*) Understanding of Human Gazing and Pointing: Knowing What and Where. *Journal of Comparative Psychology*, 121(1), 34-45.
- Pack, A. A., Herman, L. M., Hoffmann-Kuhnt, M., & Branstetter, B. K. (2002). The object behind the echo: dolphins (*Tursiops truncatus*) perceive object shape globally through echolocation. *Behavioural Processes*, 58(1-2), 1-26.
- Page, R. A., & Ryan, M. J. (2005). Flexibility in assessment of prey cues: frog-eating bats and frog calls. *Proceedings: Biological Sciences*, 272(1565), 841-847.
- Peake, T. M. (2005). Eavesdropping in communication networks. In P. K. McGregor (Ed.), *Animal Communication Networks* (pp. 13-37). Cambridge: Cambridge University Press.
- Pelphrey, K. A., Morris, J. P., & McCarthy, G. (2004a). Grasping the intentions of others: the perceived intentionality of an action influences activity in the superior temporal sulcus during social perception. *Journal of Cognitive Neuroscience*, 16(10), 1706-1716.
- Pelphrey, K. A., Morris, J. P., & McCarthy, G. (2005). Neural basis of eye gaze processing deficits in autism. *Brain*, 128(Pt 5), 1038-1048.
- Pelphrey, K. A., Singerman, J. D., Allison, T., & McCarthy, G. (2003). Brain activation evoked

by perception of gaze shifts: the influence of context. *Neuropsychologia*, 41(2), 156-170.

Pelphrey, K. A., Viola, R. J., & McCarthy, G. (2004b). When strangers pass: Processing of mutual and averted social gaze in the superior temporal sulcus. *Psychological Science*, 15, 598-603.

Penner, R. H. (1988). Attention and detection in dolphin echolocation. In P. E. Nachtigall & P. W. B. Moore (Eds.), *Animal Sonar: Process and Performance* (pp. 707-713). New York: Plenum.

Pepperberg, I. M. (1987). Interspecies communication: A tool for assessing conceptual abilities in the African Grey parrot. In G. Greenberg & E. Tobach (Eds.), *Cognition, Language and Consciousness: Interactive Levels*: Erlbaum.

Pepperberg, I. M., & McLaughlin, M. A. (1996). Effect of avian-human joint attention on allospecific vocal learning by grey parrots (*Psittacus erithacus*). *Journal of Comparative Psychology*, 110(3), 286-297.

Perneger, T. V. (1998). What's Wrong with Bonferroni Adjustments. *British Medical Journal*, 316, 1236-1238.

Perner, J. (1991). *Understanding the representational mind*. Cambridge, Mass.: MIT Press.

Perrett, D. I., & Emery, N. J. (1994). Understanding the intentions of others from visual social signals: neurophysiological evidence. *Current Psychology of Cognition*, 13, 683-694.

Perrett, D. I., Harries, M. H., Mistlin, A. J., Hietanen, J. K., Bevan, R., Thomas, S., et al. (1990). Social signals analyzed at the single cell level: someone's looking at me, something touched me, something moved! *International Journal of Comparative Psychology*, 4, 25-55.

Perrett, D. I., Hietanen, J. K., Oram, M. W., & Benson, P. J. (1992). Organization and functions of cells responsive to faces in the temporal cortex. *Philosophical Transactions: Biological Sciences*, 335(1273), 23-30.

Place, U. T. (2000). The Role of the Hand in the Evolution of Language. *Psychology*, 11(7).

Plotnik, J. M., de Waal, F. B. M., & Reiss, D. (2006). Self-recognition in an Asian elephant.

Proceedings of the National Academy of Sciences of the United States of America, 103(45), 17053-17057.

Popper, A. N. (1980). Sound emission and detection by delphinids. In L. M. Herman (Ed.), *Cetacean Behavior* (pp. 1-52). New York: John Wiley & Sons.

Povinelli, D. J., & Barth, J. (2005). Reinterpreting behavior: A human specialization? *Behavioral and Brain Sciences*, 28(5), 712-713.

Povinelli, D. J., Bering, J. M., & Giambrone, S. (2000). Toward a science of other minds: Escaping the argument by analogy. *Cognitive Science*, 24(3), 509-541.

Povinelli, D. J., Bering, J. M., Giambrone, S., & Kita, S. (2003a). Chimpanzees' 'pointing': Another error of the argument by analogy? In *Pointing: Where language, culture, and cognition meet*. (pp. 35-68): Lawrence Erlbaum Associates, Publishers.

Povinelli, D. J., Bierschwale, D. T., & Cech, C. G. (1999). Comprehension of seeing as a referential act in young children, but not juvenile chimpanzees. *British Journal of Developmental Psychology*, 17(1), 37-60.

Povinelli, D. J., & Davis, D. R. (1994). Differences Between Chimpanzees (*Pan troglodytes*) and Humans (*Homo sapiens*) in the Resting State of the Index Finger: Implications for Pointing. *Journal of Comparative Psychology*, 108(2), 134-139.

Povinelli, D. J., & Eddy, T. J. (1994). The eyes as a window: What young chimpanzees see on the other side. *Cahiers de Psychologie Cognitive/Current Psychology of Cognition*, 13(5), 695-705.

Povinelli, D. J., & Eddy, T. J. (1996a). Chimpanzees: Joint Visual Attention. *Psychological Science*, 7(3), 129-135.

Povinelli, D. J., & Eddy, T. J. (1996b). What young chimpanzees know about seeing. *Monographs of the Society for Research in Child Development*, 61(3), i-vi, 1-152; discussion 153-191.

Povinelli, D. J., & Eddy, T. J. (1997). Specificity of gaze-following in young chimpanzees. *British Journal of Developmental Psychology*, 15(2), 213-222.

- Povinelli, D. J., Gallup, G. G., Jr., Eddy, T. J., & Bierschwale, D. T. (1997a). Chimpanzees recognize themselves in mirrors. *Animal Behaviour*, 53(5), 1083-1088.
- Povinelli, D. J., & Giambrone, S. (1999). Inferring other minds: Failure of the argument by analogy. *Philosophical Topics*, 27, 167-201.
- Povinelli, D. J., & O'Neill, D. K. (2000). Do chimpanzees use their gestures to instruct each other? In S. Baron-Cohen, H. Tager-Flusberg & D. J. Cohen (Eds.), *Understanding other minds: Perspectives from autism* (pp. 459-487). Oxford: Oxford University Press.
- Povinelli, D. J., Perilloux, H. K., Reaux, J. E., & Bierschwale, D. T. (1998). Young and juvenile chimpanzees' (*Pan troglodytes*) reactions to intentional versus accidental and inadvertent actions. *Behavioural Processes*, 42(2), 205-218.
- Povinelli, D. J., Reaux, J. E., Bierschwale, D. T., Allain, A. D., & Simon, B. B. (1997b). Exploitation of pointing as a referential gesture in young children, but not adolescent chimpanzees. *Cognitive Development*, 12(4), 327-365.
- Povinelli, D. J., Theall, L. A., Reaux, J. E., & Dunphy-Lelii, S. (2003b). Chimpanzees spontaneously alter the location of their gestures to match the attentional orientation of others. *Animal Behaviour*, 66, 71-79.
- Povinelli, D. J., & Vonk, J. (2004). We Don't Need a Microscope to Explore the Chimpanzee's Mind. *Mind and Language*, 19(1), 1-28.
- Povinelli, D. J., & Vonk, J. (2006). We don't need a microscope to explore the chimpanzee's mind. In S. Hurley & M. Nudds (Eds.), *Rational Animals?* (pp. 385-412). Oxford: Oxford University Press.
- Premack, D. (1986). *Gavagai!* Cambridge, MA: MIT Press.
- Premack, D. (1988). 'Does the chimpanzee have a theory of mind?' revisited. In R. W. Byrne & A. Whiten (Eds.), *Machiavellian intelligence: Social expertise and the evolution of intellect in monkeys, apes and humans* (pp. 160-179). Oxford, England: Oxford University Press.
- Premack, D. (1990). The infant's theory of self-propelled objects. *Cognition*, 36(1), 1-16.

- Premack, D. G., & Woodruff, G. (1978). Does the chimpanzee have a theory of mind? .
Behavioral and Brain Sciences
- Pryor, S. H. (1990). Non-acoustic communication in small cetaceans: glance, touch, position, gesture, and bubbles. In J. A. Thomas & R. A. Kastelein (Eds.), *Sensory Abilities of Cetaceans: Laboratory and Field Evidence* (Vol. BBS, pp. 537-544). New York: Plenum Press.
- Puce, A., Allison, T., Gore, J. C., & McCarthy, G. (1995). Face-sensitive regions in human extrastriate cortex studied by functional MRI. *Journal of Neurophysiology*, 74(3), 1192-1199.
- Raos, V., Umiltà, M. A., Murata, A., Fogassi, L., & Gallese, V. (2006). Functional properties of grasping-related neurons in the ventral premotor area F5 of the macaque monkey. *J Neurophysiol*, 95(2), 709-729.
- Razak, K. A., Fuzessery, Z. M., & Lohuis, T. D. (1999). Single Cortical Neurons Serve Both Echolocation and Passive Sound Localization. *The Journal of Neurophysiology* 81(3), 1438-1442.
- Reddy, V. (1998). The strategic use of gaze to face in joint attention. *Infant Behavior and Development*, 21, 640-640.
- Reiss, D., & Marino, L. (2001). Mirror self-recognition in the bottlenose dolphin: a case of cognitive convergence. *Proceedings of the National Academy of Sciences of the United States of America*, 98(10), 5937-5942.
- Reiss, G. (1988). Observations on the development of echolocation in young bottlenose dolphins. In *Animal Sonar: Process and Performance* (pp. 121-127).
- Ricciardelli, P., Bricolo, E., Aglioti, S. M., & Chelazzi, L. (2002). My eyes want to look where your eyes are looking: exploring the tendency to imitate another individual's gaze. *Neuroreport*, 13(17), 2259-2264.
- Rilling, J. K., Sanfey, A. G., Aronson, J. A., Nystrom, L. E., & Cohen, J. D. (2004). The neural correlates of theory of mind within interpersonal interactions. *Neuroimage*(22), 1694-1703.

- Ristau, C. A. (1991). Before mindreading: attention, purposes and deception in birds? In A. Whiten (Ed.), *Natural Theories of Mind*. Oxford: Blackwell.
- Rizzolatti, G., & Craighero, L. (2004). The mirror-neuron system. *Annual Review of Neuroscience*, 27, 169-192.
- Rizzolatti, G., Fadiga, L., Fogassi, L., & Gallese, V. (1999). Resonance behaviors and mirror neurons. *Archivio Italiano di Biologia*, 137(2-3), 85-100.
- Rizzolatti, G., & Luppino, G. (2001). The cortical motor system. *Neuron*, 31(6), 889-901.
- Roitblat, H. L. (2004). Object Recognition by Dolphins. In J. A. Thomas, C. Moss & M. Vater (Eds.), *Echolocation in bats and dolphins* (pp. 268-272). Chicago: The University of Chicago Press.
- Roitblat, H. L., Au, W. W. L., Shizumura, R., & Moons, G. (1995). Sonar recognition of targets embedded in sediment. *Neural Networks*, 8, 1263-1273.
- Ross, G. (1984). The smaller cetaceans of the south east coast of southern Africa. *Annals of the Cape Provincial Museum (Natural History)*, 15, 173-400.
- Russell, C. L. (1998). Joint attention in young chimpanzees: Foundations of intentional communication. *Infant Behavior and Development*, 21, 192-192.
- Russell, C. L., Bard, K. A., & Adamson, L. B. (1997). Social referencing by young chimpanzees (*Pan troglodytes*). *Journal of Comparative Psychology*, 111(2), 185-193.
- Sabbagh, M. A., Henderson, A. M. E., & Baldwin, D. A. (2006). What infants' understanding of referential intentions tells us about the neuro-cognitive underpinnings of word learning. In R. Flom, L. K. & D. Muir (Eds.), *Gaze-Following: Its development and significance* (pp. 171-192). Mahwah, NJ: Erlbaum.
- Sakai, M., Hishii, T., Takeda, S., & Kohshima, S. (2006a). Flipper rubbing behaviors in wild bottlenose dolphins (*Tursiops aduncus*). *Marine Mammal Science*, 22(4), 966-978.
- Sakai, M., Hishii, T., Takeda, S., & Kohshima, S. (2006b). Laterality of flipper rubbing behaviour in wild bottlenose dolphins (*Tursiops aduncus*): Caused by asymmetry of eye use? *Behavioural Brain Research*, 170, 204-210.

- Savage-Rumbaugh, E. S. (1986). *Ape language: From conditioned response to symbol*. New York: Columbia University Press.
- Savage-Rumbaugh, E. S., Rumbaugh, D., & Boysen, S. T. (1978). Sarah's problems in comprehension. *Behavioral and Brain Sciences*, *1*, 555-557.
- Savage-Rumbaugh, E. S., & Rumbaugh, D. M. (1978). Symbolization, language, and chimpanzees: a theoretical reevaluation based on initial language acquisition processes in four young *Pan troglodytes*. *Brain and Language*, *6*(3), 265-300.
- Savage-Rumbaugh, E. S., Shankar, S. G., & Taylor, T. J. (1998). *Apes, language, and the human mind*. Oxford: Oxford University Press.
- Saxe, R. (2006). Uniquely human social cognition. *Current Opinion in Neurobiology*, *16*(2), 235-239.
- Saxe, R., Xiao, D. K., Kovacs, G., Perrett, D. I., & Kanwisher, N. (2004). A region of right posterior superior temporal sulcus responds to observed intentional actions. *Neuropsychologia*, *42*(11), 1435-1446.
- Sayigh, L. S. (2002). Signature Whistles. In W. F. Perrin, B. Würsig & J. G. M. Thewissen (Eds.), *Encyclopedia of Marine Mammals* (pp. 1081-1083). San Diego: Academic Press.
- Scaife, M., & Bruner, J. S. (1975). The capacity for joint visual attention in the infant. *Nature*, *253*(5489), 265-266.
- Scerif, G., Gomez, J. C., & Byrne, R. W. (2004). What do Diana monkeys know about the focus of attention of a conspecific. *Animal Behavior*, *68*(6), 1239-1247.
- Schotten, M., Whitlow Jr, J. W., Lammers, M. O., & Aubauer, R. (2004). Echolocation Recordings and Localization of Wild Spinner Dolphins (*Stenella longirostris*) and Pantropical Spotted Dolphins (*S. attenuata*) Using a Four-Hydrophone Array. In J. A. Thomas, C. Moss & M. Vater (Eds.), *Echolocation in bats and dolphins* (pp. 393-399). Chicago: The University of Chicago Press.
- Scronce, B. L., & Johnson, C. S. (1976). Bistatic target detection by a bottlenosed porpoise. *Journal of the Acoustical Society of America*, *59*(4), 1001-1002.

- Searle, J. R. (1983). *Intentionality, an essay in the philosophy of mind*. Cambridge; New York: Cambridge University Press.
- Searle, J. R. (1984). *Minds, brains, and science*. Cambridge, Mass.: Harvard University Press.
- Sebanz, N., Bekkering, H., & Knoblich, G. (2006). Joint action: bodies and minds moving together. *Trends in Cognitive Sciences*, *10*(2), 70-76.
- Seyfarth, R. M., Cheney, D. L., & Marler, P. (1980a). Monkey responses to three different alarm calls: evidence of predator classification and semantic communication. *Science*, *210*(4471), 801-803.
- Seyfarth, R. M., Cheney, D. L., & Marler, P. (1980b). Vervet monkey alarm calls: Semantic communication in a free-ranging primate. *Animal Behavior*, *28*, 1070-1094.
- Shapiro, A. D., Janik, V. M., & Slater, P. J. (2003). A gray seal's (*Halichoerus grypus*) responses to experimenter-given pointing and directional cues. *Journal of Comparative Psychology*, *117*(4), 355-362.
- Shirakihara, M., Yoshida, H., & Shirakihara, K. (2003). Indo-Pacific bottlenose dolphins *Tursiops aduncus* in Amakusa, western Kyushu, Japan. *Fisheries Science*, *69*, 654-656.
- Slaughter, V., & McConnell, D. (2003). Emergence of joint attention: relationships between gaze following, social referencing, imitation, and naming in infancy. *Journal of Genetic Psychology*, *164*(1), 54-71.
- Slocombe, K. E., & Zuberbuhler, K. (2006). Food-associated calls in chimpanzees: responses to food types or food preferences? *Animal Behaviour*, *72*(5), 989-999.
- Soproni, K., Miklosi, A., Topal, J., & Csanyi, V. (2001). Comprehension of human communicative signs in pet dogs (*Canis familiaris*). *Journal of Comparative Psychology*, *115*(2), 122-126.
- Spitz, S. S., Herman, L. M., & Pack, A. A. (2000). Measuring sizes of humpback whales (*Megaptera novaeangliae*) by underwater videogrammetry. *Marine Mammal Science*, *16*(3), 664-676.

- Steiger, J. H. (1980). Tests for comparing elements of a correlation matrix. *Psychological Bulletin*, 87, 245-251.
- Stolen, M. K., Odell, D. K., & Barros, N. B. (2002). Growth of bottlenose dolphins (*Tursiops truncatus*) from the Indian River Lagoon system, Florida, U.S.A. . *Marine Mammal Science*, 18(2), 348–357.
- Stone, V. E., Baron-Cohen, S., & Knight, R. T. (1998). Frontal Lobe Contributions to Theory of Mind. *Journal of Cognitive Neuroscience*, 10(5), 640-656.
- Stowe, M. K., Turlings, T. C., Loughrin, J. H., Lewis, W. J., & Tumlinson, J. H. (1995). The chemistry of eavesdropping, alarm, and deceit. *Proceedings of the National Academy of Sciences of the United States of America*, 92(1), 23-28.
- Striano, T., Reid, V. M., & Hoehl, S. (2006). Neural mechanisms of joint attention in infancy. *European Journal of Neuroscience*, 23(10), 2819-2823.
- Suddendorf, T., & Whiten, A. (2001). Mental evolution and development: evidence for secondary representation in children, great apes, and other animals. *Psychological Bulletin*, 127(5), 629-650.
- Suga, N. (1990). Cortical computational maps for auditory imaging. *Neural Networks*, 3, 3-12.
- Thomas, J. A., Moss, C., & Vater, M. (2004). *Echolocation in bats and dolphins*. Chicago: The University of Chicago Press.
- Tolley, K. A., Read, A. J., Wells, R. S., Urian, K. W., Scott, M. D., Irvine, A. B., et al. (1995). Sexual dimorphism in wildlife bottlenose dolphins (*Tursiops truncatus*) from Sarasota, Florida. *Journal of Mammalogy*, 76(4), 1190-1198.
- Tomasello, M. (1988). The role of joint attentional processes in early language development. *Language Sciences*, 10(1), 69-88.
- Tomasello, M. (1995). Joint attention as social cognition. In C. Moore & P. J. Dunham (Eds.), *Joint attention: its origin and role in development* (pp. 103–130). Hillsdale, N.J.
- Tomasello, M. (1999). *The cultural origins of human cognition*. Cambridge, MA: Harvard University Press.

- Tomasello, M., & Call, J. (1997). *Primate Cognition*: Oxford University Press
- Tomasello, M., & Call, J. (2006). Do chimpanzees know what others see - or only what they are looking at? In S. Hurley & M. Nudds (Eds.), *Rational Animals?* (pp. 371-384). Oxford: Oxford University Press.
- Tomasello, M., Call, J., & Gluckman, A. (1997). Comprehension of novel communicative signs by apes and human children. *Child Development*, 68(6), 1067-1080.
- Tomasello, M., Call, J., & Hare, B. (1998). Five primate species follow the visual gaze of conspecifics. *Animal Behaviour*, 55(4), 1063-1069.
- Tomasello, M., Call, J., & Hare, B. (2003). Chimpanzees understand psychological states - the question is which ones and to what extent. *Trends in Cognitive Sciences*, 7(4), 153-156.
- Tomasello, M., & Carpenter, M. (2005). The emergence of social cognition in three young chimpanzees. *Monographs of the Society for Research in Child Development*, 70(1), vii-132.
- Tomasello, M., Carpenter, M., Call, J., Behne, T., & Moll, H. (2005). Understanding and sharing intentions: the origins of cultural cognition. *Behavioral and Brain Sciences*, 28(5), 675-691; discussion 691-735.
- Tomasello, M., & Haberl, K. (2003). Understanding attention: 12- and 18-month-olds know what is new for other persons. *Developmental Psychology*, 39(5), 906-912.
- Tomasello, M., Hare, B., & Agnetta, B. (1999). Chimpanzees, *Pan troglodytes*, follow gaze direction geometrically. *Animal Behaviour*, 58(4), 769-777.
- Tomasello, M., Kruger, A. C., & Ratner, H. H. (1993). Cultural learning. *Behavioral and Brain Sciences*, 16, 495-552.
- Topal, J., & Csanyi, V. (1994). The effect of eye-like schema on shuttling activity of wild house mice (*Mus musculus domesticus*): Context-dependent threatening aspects of the eyespot patterns. *Animal Learning & Behavior*, 22, 96-102.
- Trevarthen, C. (1979). Communication and cooperation in early infancy: a description of

- primary intersubjectivity. In M. Bullowa (Ed.), *Before speech. The beginning of interpersonal communication* (pp. 321-347). Cambridge: Cambridge University Press.
- Trevarthen, C., & Hubley, P. (1978). Secondary intersubjectivity: confidence, confiding and acts of meaning in the first year. In *Action, gesture and symbol: the emergence of language* (pp. 183-229). London: London Academic Press
- Tschudin, A., Call, J., Dunbar, R. I., Harris, G., & van der Elst, C. (2001). Comprehension of signs by dolphins (*Tursiops truncatus*). *Journal of Comparative Psychology*, *115*(1), 110-115.
- Tschudin, A. J. P. C. (2006). Belief attribution tasks with dolphins: what social minds can reveal about animal rationality. In S. Hurley & M. Nudds (Eds.), *Rational Animals?* (pp. 413-438). Oxford: Oxford University Press.
- Tyack, P. L., & Clark, C. W. (2000). Acoustic communication in whales and dolphins. In W. W. L. Au, A. N. Popper & R. R. Fay (Eds.), *Hearing by whales and dolphins* (pp. 156-224). New York: Springer Handbook of Auditory Research.
- Ulanovsky, N., Fenton, M. B., Tsoar, A., & Korine, C. (2004). Dynamics of jamming avoidance in echolocating bats. *Proceedings: Biological Sciences*, *271*(1547), 1467-1475.
- Vallin, A., Jakobsson, S., Lind, J., & Wiklund, C. (2005). Prey survival by predator intimidation: an experimental study of peacock butterfly defence against blue tits. *Proc Biol Sci*, *272*(1569), 1203-1207.
- Vander Waal, S. B. (1990). *Food hoarding in animals*. Chicago: University of Chicago Press.
- Vea, J., & Sabater-Pi, J. (1998). Spontaneous Pointing Behaviour in the Wild Pygmy Chimpanzee (*Pan paniscus*). *Folia Primatol (Basel)*, *69*(5), 289-290.
- Vick, S. J., & Anderson, J. (2000a). Learning and limits of use of gaze by capuchin monkeys in an object-choice task. *Journal of Comparative Psychology*, *114*, 200-207.
- Vick, S. J., & Anderson, J. R. (2000b). Learning and limits of use of eye gaze by capuchin monkeys (*Cebus apella*) in an object-choice task. *Journal of Comparative Psychology*, *114*(2), 200-207.

- Villalobos, M. E., Mizuno, A., Dahl, B. C., Kemmotsu, N., & Muller, R. A. (2005). Reduced functional connectivity between V1 and inferior frontal cortex associated with visuomotor performance in autism. *Neuroimage*, 25(3), 916-925.
- Walter, H. E., Adenzato, M., Ciaramidaro, A., Enrici, I., Pia, L., & Bara, B. G. (2004). Understanding intentions in social interaction: the role of the anterior paracingulate cortex. *Journal of Cognitive Neuroscience*, 16, 1854-1863.
- Wang, J. Y., Chou, L.-S., & White, B. N. (2000). Osteological differences between two sympatric forms of bottlenose dolphins (genus *Tursiops*) in Chinese waters. *Journal of Zoology* 252, 147-162.
- Wang, J. Y., Chou, L. S., & White, B. N. (1999). Mitochondrial DNA analysis of sympatric morphotypes of bottlenose dolphins (genus: *Tursiops*) in Chinese waters. *Molecular Ecology*, 8(10), 1603-1612.
- Watve, M., Thakar, J., Kale, A., Puntambekar, S., Shaikh, I., Vaze, K., et al. (2002). Bee-eaters (*Merops orientalis*) respond to what a predator can see. *Animal Cognition*, 5(4), 253-259.
- Wellman, H. M., & Woolley, J. D. (1990). From simple desires to ordinary beliefs: the early development of everyday psychology. *Cognition*, 35(3), 245-275.
- Wetherby, A. M., Cain, D. H., Yonclas, D. G., & Walker, V. G. (1988). Analysis of intentional communication of normal children from the prelinguistic to the multiword stage. *Journal of Speech and Hearing Research*, 31(2), 240-252.
- Whiten, A., & Byrne, R. W. (1988). Tactical deception in primates. *Behavioral and brain sciences*, 11(2).
- Williams, J. H., Waiter, G. D., Perra, O., Perrett, D. I., & Whiten, A. (2005). An fMRI study of joint attention experience. *Neuroimage*, 25(1), 133-140.
- Williams, J. H., Whiten, A., & Singh, T. (2004). A systematic review of action imitation in autistic spectrum disorder. *Journal of Autism and Developmental Disorders*, 34(3), 285-299.
- Wong, G. S. K., & Zhu, S. (1995). Speed of sound in seawater as a function of salinity, temperature and pressure. *Journal of the Acoustical Society of America*, 97(3), 1732-

1736.

Wood, F. G., & Evans, W. E. (1980). Adaptiveness and ecology of echolocation in toothed whales. In R. G. Busnel & J. F. Fish (Eds.), *Animal Sonar Systems* (pp. 381-425). New York: Plenum Press.

Xitco, M. J., Gory, J. D., & Kuczaj, S. A. I. (2001). Spontaneous pointing by bottlenose dolphins (*Tursiops truncatus*). *Animal Cognition*, 4, 115-123.

Xitco, M. J., Jr., Gory, J. D., & Kuczaj, S. A., II. (2004). Dolphin pointing is linked to the attentional behavior of a receiver. *Animal Cognition*, 8, 231-238.

Xitco, M. J., & Roitblat, H. L. (1996). Object recognition through eavesdropping: Passive echolocation in bottlenose dolphins. *Animal Learning & Behavior*, 24(4), 355-365.

Yamane, S., Kaji, S., & Kawano, K. (1988). What facial features activate face neurons in the inferotemporal cortex of the monkey? *Experimental Brain Research*, V73(1), 209-214.

Zahavi, A. (1997). *The handicap principle*. New York: Oxford University Press.

Zuberbuhler, K. (2000). Referential labeling in Diana monkeys. *Animal Behaviour*, 59(5), 917-927.

Appendices

Appendix A: Ethical Permission from the IACUC

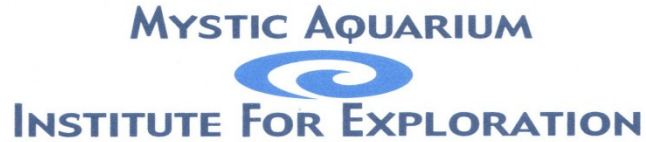

July 11, 2006

To Whom It May Concern:

The Institutional Animal Care and Use Committee (IACUC) for Mystic Aquarium & Institute for Exploration has reviewed PI Dudzinski's National Science Foundation proposal for the Animal Behavior program.

Dudzinski's proposal includes non-invasive observations of dolphins from the underwater perspective. These observations are opportunistic and based on when dolphins swim into view. We concur with Dudzinski's assessment that there will be minimal, if any, disturbance to these animals.

We approve the proposed project based on animal welfare and support it on scientific merit.

Thank you.

Sincerely,

A handwritten signature in blue ink, appearing to read "Neal A. Overstrom". The signature is stylized with loops and a long horizontal stroke extending to the right.

Neal A. Overstrom
Aquarium Vice President
Chairman, Mystic Aquarium & Institute for Exploration IACUC

Appendix B: Dolphin Communication Project Code of Conduct

1) DO NOT TOUCH the dolphins. If the dolphins want physical contact with people, they will initiate it. If you try to touch one dolphin, then all the dolphins invariably leave the area. Not only does this adversely affect dolphin behavior but it irritates the other people with your group since everyone loses on the swim.

2) DO NOT CHASE or swim after, or follow the dolphins away from the group of humans. They are incredibly graceful and powerful swimmers. There is no way any human could keep up with them. Swimming after them when they move off simply forces them to move a bit further away.

3) ALWAYS LISTEN to your Dolphin Guide and Captain. Not only do they have many hours (and often years) experience around the dolphins, they also have much experience on the water. Most of them are interested to answer questions and share their knowledge. If they direct you to a certain direction, swim that way. It will usually be the best place to see the dolphins. The ocean is an amazing entity! Your trip may have started out just to see dolphins, but you can actually gain much more and learn about the ocean, currents, wind and other animals in the area, like Streaked Shearwaters and flying fish.

4) Remember your limits! Don't push yourself - enjoy your trip. If you are not confident about your skin diving abilities, or don't feel like going in the water, DON'T DO IT. You can have a lot of fun watching from the boat.

5) LOOK DOWN when actually in the water. The dolphins will often swim right underneath you or from behind you.

6) Be willing to snorkel below the surface but be careful and aware of your own limitations. If you feel uncomfortable in the water, ask your Dolphin Guide for suggestions. Snorkeling is a fun sport, but only when one is comfortable. This will also enhance your experience with the dolphins.

7) When surfacing to breathe, look up to avoid any potential objects in your way.

8) BE AWARE of the boat when you are in the water. Be ready to enter the water and be ready to exit when told to do so. When entering, go feet first, holding your mask against your face with your snorkel in your mouth. The exit from each boat is different, so be sure to listen to the captain and dolphin guide for directions. Generally, look up and forward to see the boat. With waves, it can be difficult to see the boat from underwater.

9) Dolphin swimming and watching is fun, but tiring. Try to be in good condition to skin dive. The

more experience you have in the water, the better time you will have.

10) If you are an experienced skin diver, you may want to try one or more of the following tips:

- a) The best approaches underwater to swimming dolphins seem to be from an angle that is from the side or at about 45° (roughly). Direct or head-to-head approaches or fast swims at 90° to others usually signify aggressive activity. Also, at these angles you may be able to determine a dolphin's sex.
- b) Try dolphin kicking (like butterfly swimming with both legs together). It is fast but requires a lot of energy.
- c) Underwater turns, circle swimming and flips may indicate play to dolphins. They may try to imitate you doing these behaviors.
- d) Use your body as a tool to communicate. Remember the streamlined shape of the dolphins.

Remember, the dolphins seem interested in us and therefore come to swim around us. We are visitors to their world and should not abuse the welcome they extend to us. So, let's reciprocate by not infringing on their activity and by not polluting the oceans. With these simple guidelines, we can show our respect for the ocean and the creatures that live in it.